

## Single Pack NLX15KK.3 220-240V 50Hz RSCR

Codice Imballo Singolo: **195B4150**

Posizione	Titolo	Codice	Quantità
1	Compressor NLX15KK.3	105H6506	1
2	PTC starting device (220V, 250hm, 4.8mm)	103N0021	1
3	Protection screen for PTC	103N0476	1
4	Run capacitor (3.5µF 320V, 4.8mm)	117-7140	1
5	Cord relief	103N1010	1
6	Cover	103N2010	1
7	Bolt joint for one compressor   M6   ø16mm	118-1917	1

**Secop GmbH** · Lise-Meitner-Straße 29 · 24941 Flensburg, Germany · Tel: +49 46149410 · [www.secop.com](http://www.secop.com)

Secop non si assume alcuna responsabilità per eventuali errori presenti in cataloghi, brochure e altro materiale stampato. Secop si riserva il diritto di modificare i propri prodotti senza preavviso. Ciò vale anche per i prodotti già ordinati, a condizione che tali modifiche possano essere apportate senza che siano necessarie modifiche successive alle specifiche già concordate. Tutti i marchi presenti in questo materiale sono di proprietà delle rispettive aziende. Secop e il logo Secop sono marchi di Secop GmbH. Tutti i diritti sono riservati.

## NLX15KK.3 High Energy-optimized Compressor R600a 220-240V 50Hz

### General

Code number	105H6506
Approvals	EN 60335-2-34 with Annex AA
Compressors on pallet	80

### Application

Application	LBP		
Frequency	Hz	50	60
Evaporating temperature	°C	-35 to -10	-
Voltage range	V	198 - 254	-
Max. condensing temperature continuous (short)	°C	60 (70)	-
Max. winding temperature continuous (short)	°C	120 (125)	-

### Cooling requirements

Frequency	Hz	50			60		
Application		LBP	MBP	HBP	LBP	MBP	HBP
32°C		S	-	-	-	-	-
38°C		S	-	-	-	-	-
43°C		S	-	-	-	-	-
Remarks on application:							

### Motor

Motor type	RSCR		
LRA (rated after 4 sec. UL984), HST   LST	A	-	6.6
Cut in Current, HST   LST	A	-	9.8
Resistance, main   start winding (25°C)	Ω	14.6	22.8

### Design

Displacement	cm <sup>3</sup>	14.65
Oil quantity (type)	cm <sup>3</sup>	270 (mineral)
Maximum refrigerant charge	g	150
Free gas volume in compressor	cm <sup>3</sup>	2360
Weight without electrical equipment	kg	10.8

### Dimensions

Height	mm	A	203
		B	197
		B1	-
		B2	-
Suction connector	location/I.D. mm   angle	C	6.2   15°
	material   comment		Cu-plated steel   Al cap
Process connector	location/I.D. mm   angle	D	6.2   25°
	material   comment		Cu-plated steel   Al cap
Discharge connector	location/I.D. mm   angle	E	5.0   21°
	material   comment		Cu-plated steel   Al cap
Oil cooler connector	location/I.D. mm   angle	F	-
	material   comment		-
Connector tolerance	I.D. mm		±0.09, on 5.0 +0.12/+0.20
Remarks:			

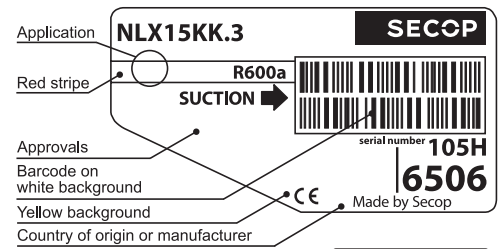

- S = Static cooling normally sufficient
- O = Oil cooling
- F<sub>1</sub> = Fan cooling 1.5 m/s (compressor compartment temperature equal to ambient temperature)
- F<sub>2</sub> = Fan cooling 3.0 m/s necessary
- SG = Suction gas cooling normally sufficient
- = not applicable in this area

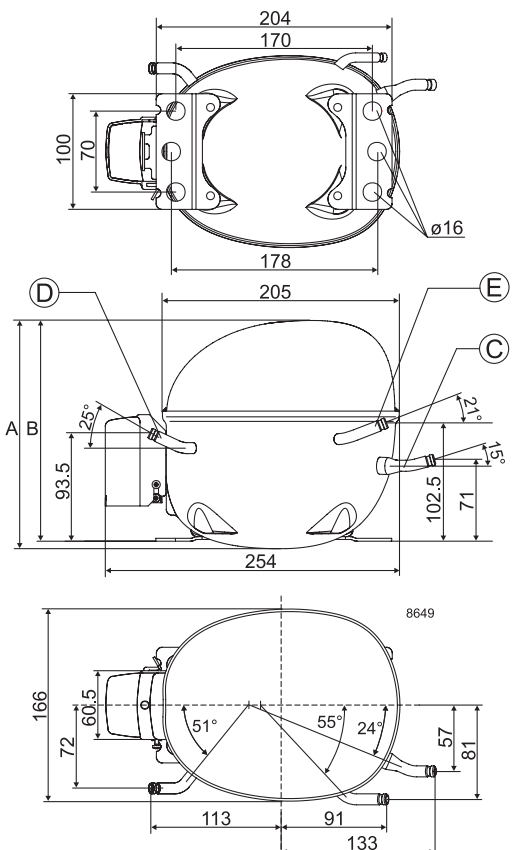

**EN 12900 Household (CECOMAF)** 220V, 50Hz, RC 3.5 µF, ePTC consumption incl., static cooling

Evap. temp in °C	-45	-40	-35	-30	-25	-23.3	-20	-15	-10	-6.7	-5	0	5	7.2	10	15	20
Capacity in W			109	144	190	208	247	317	403								
Power cons. in W			97	112	130	137	152	177	206								
Current cons. in A			0.50	0.52	0.59	0.63	0.70	0.84	0.99								
COP in W/W			1.11	1.28	1.45	1.51	1.62	1.79	1.96								

**ASHRAE LBP** 220V, 50Hz, RC 3.5 µF, ePTC consumption incl., static cooling

Evap. temp in °C	-45	-40	-35	-30	-25	-23.3	-20	-15	-10	-6.7	-5	0	5	7.2	10	15	20
Capacity in W			132	175	231	254	302	388	493								
Power cons. in W			97	112	130	137	152	177	206								
Current cons. in A			0.49	0.52	0.59	0.63	0.70	0.84	0.99								
COP in W/W			1.36	1.57	1.78	1.85	1.98	2.19	2.39								

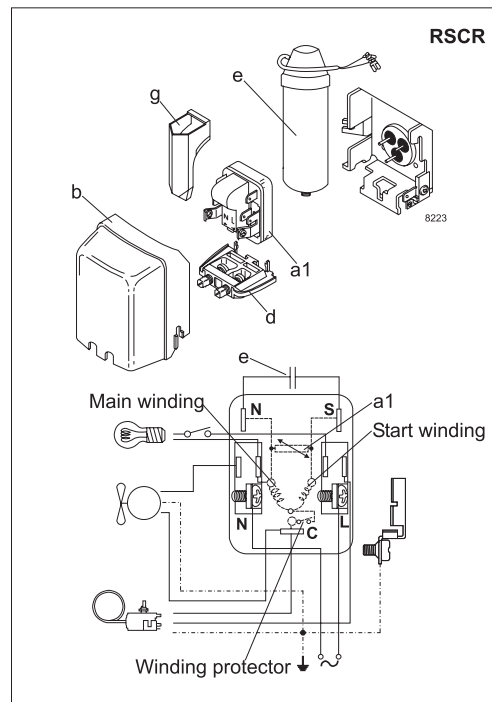

Accessories for	NLX15KK.3	Figure	Code number
PTC starting device	6.3 mm spade connectors	a1	-
	4.8 mm spade connectors		103N0021
ePTC starting device	4.8 mm spade connectors		103N0050
Cover		b	103N2010
Cord relief		d	103N1010
Run capacitor 3.5 µF (compulsory)	6.3 mm spade connectors	e	-
	4.8 mm spade connectors		117-7140
Protection screen for PTC		g	103N0476

Test conditions	EN 12900/CECOMAF	ASHRAE
Condensing temperature	55°C	54.4°C
Ambient temperature	32°C	32°C
Suction gas temperature	32°C	32°C
Liquid temperature	no subcooling	32°C

Mounting accessories	Code number	
Bolt joint for one comp.	Ø: 16 mm	118-1917
Bolt joint in quantities	Ø: 16 mm	118-1918
Snap-on in quantities	Ø: 16 mm	118-1919

Secop accepts no responsibility for possible errors in catalogs, brochures, and other printed material. Secop reserves the right to alter its products without notice. This also applies to products already on order provided that such alterations can be made without subsequential changes being necessary to specifications already agreed. All trademarks in this material are the property of the respective companies. Secop and the Secop logotype are trademarks of Secop GmbH. All rights reserved. [www.secop.com](http://www.secop.com)



8238-20

# NL Compressors

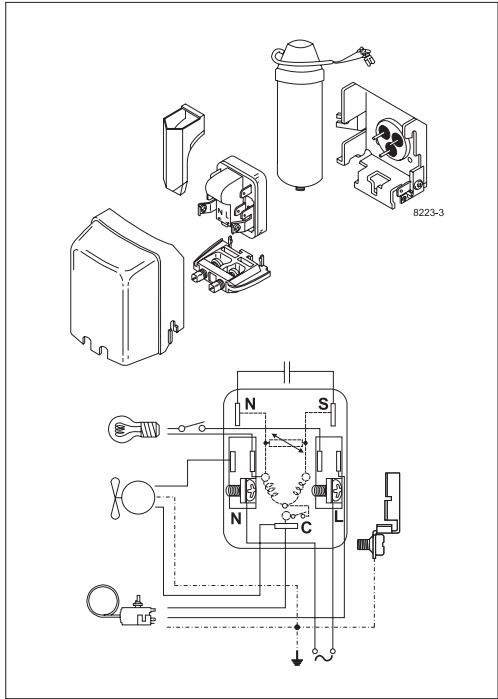
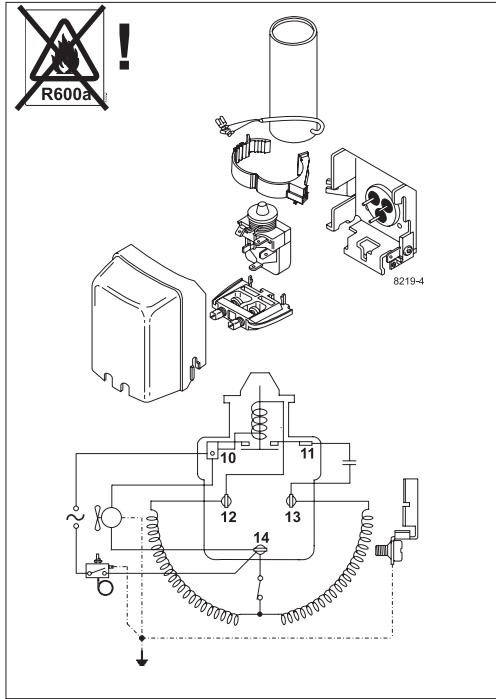
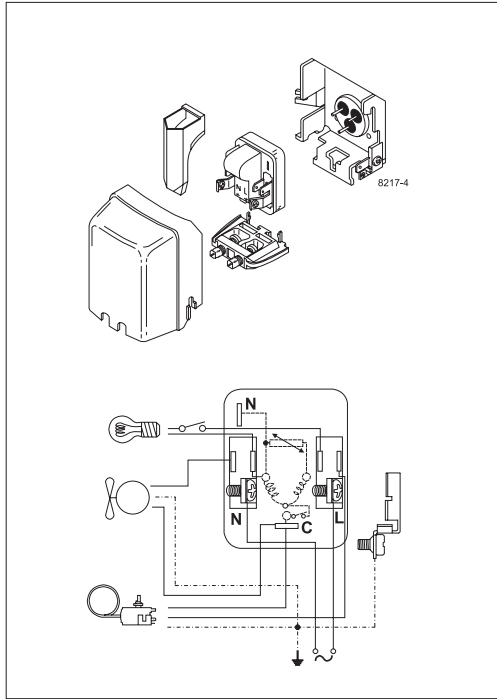



## Service/Repair – R600a, R290



8545

## Brazing on Suction Connectors (Direct Intake)

representative image



**! max. 150°C/302°F !  
at socket**  
brazing solder: phosphor (LP7) or silver

Refer to Product Bulletin:  
**Brazing on Suction Connectors  
(Compressors with Direct Suction Intake)**

Secop accepts no responsibility for possible errors in catalogs, brochures, and other printed material. Secop reserves the right to alter its products without notice. This also applies to products already on order provided that such alterations can be made without subsequential changes being necessary to specifications already agreed. All trademarks in this material are the property of the respective companies. Secop and the Secop logotype are trademarks of Secop GmbH. All rights reserved. [www.secop.com](http://www.secop.com)