

Single Pack SC12CNX.2 220-240V 50Hz CSIR

Codice Imballo Singolo: **195B4168**

Posizione	Titolo	Codice	Quantità
1	Compressor SC12CNX.2	104H8266	1
2	Starting relay	117U7003	1
3	Starting capacitor (80 μ F 220V, 6.3mm)	117U5017	1
4	Cord relief	103N1004	1
5	Cover	103N2009	1
6	Bolt joint for one compressor M6 \varnothing 16mm	118-1917	1

Secop GmbH • Lise-Meitner-Straße 29 • 24941 Flensburg, Germany • Tel: +49 46149410 • www.secop.com

Secop non si assume alcuna responsabilità per eventuali errori presenti in cataloghi, brochure e altro materiale stampato. Secop si riserva il diritto di modificare i propri prodotti senza preavviso. Ciò vale anche per i prodotti già ordinati, a condizione che tali modifiche possano essere apportate senza che siano necessarie modifiche successive alle specifiche già concordate. Tutti i marchi presenti in questo materiale sono di proprietà delle rispettive aziende. Secop e il logo Secop sono marchi di Secop GmbH. Tutti i diritti sono riservati.

Model

Designation	SC12CNX.2	220-240V/50Hz 1~	Sales code:	104H8266
-------------	------------------	------------------	-------------	-----------------

Compressor design

Oil type	Polyolester	Refrigerant(s)	R290
Oil viscosity	22cST	Displacement	12,87cm ³ / 0,79cu.in
Oil quantity	500cm ³ / 16,9fl.oz	Compressors on pallet	80
Refr. charge - tech. limit	150g / 5,3oz		
Free gas volume comp.	1410cm ³ / 47,7fl.oz		
Weight	13,1kg / 28,9lbs		
Motor protection	1# internal		
Winding resistance main	6,9Ω (at 25°C)		
Winding resistance aux	11Ω (at 25°C)		
Max. winding temp.	125°C / 257°F		
Max. discharge temp.	135°C / 275°F		



General - Configurations with SC12CNX.2

	Conf. 1
Motorconfiguration	CSIR
Power supply (nominal)	220-240V/50Hz
Number of phases	1
Voltage range	198-254V
Approvals	CCC, VDE
Starting torque	HST
Note	- / -

Applications with SC12CNX.2

	Conf. 1
Refrigerant	R290
Application	LBP
System cooling	fan 3m/s
Hot gas defrost	OK
Long interval pull down	OK

Electrical data - Configurations with SC12CNX.2

	Conf. 1
Starting device type	relay
Run capacitor	-/-
Start capacitor	80μF
LRA (locked rotor amps / 4s)	23,4A
RLA (rated load amps / 1s)	4,3A
Cut in current	23,4A

Model

Designation

SC12CNX.2

220-240V/50Hz 1~

Sales code:

104H8266

Compressor dimensions

Housing	A Height	209mm / 8,23in
	B Height	203mm / 7,99in
	C Length shell	218mm / 8,58in
	D Length w. cover	255mm / 10,04in
	E Width	151mm / 5,94in

Connectors	Suction X	Discharge Y	Process Z
Diameter [mm]	øi 8,11-8,29	øi 6,11-6,29	øi 6,11-6,29
(i:inside, o:outside) [in]	øi 0,32-0,33	øi 0,24-0,25	øi 0,24-0,25
Material	copper	copper	copper
Horizontal angle ±2°	37°	37°	143°
Vertical angle ±2°	30°	0°	150°
Position l/h/w [mm]	107/183/55	115/100/63	-107/183/55
[in]	4,2/7,2/2,2	4,5/3,9/2,5	-4,2/7,2/2,2
Straight tube l. [mm]	12	12	12
[in]	0,5	0,5	0,5



Compressor fixation



Bolt joint



Snap-on



Mounting accessories

Mounting accessories	one comp.	multi pack
Bolt joint M6 ø16mm	118-1917	118-1918
Bolt joint ø1/4" ø16mm	118-1946	
Bolt joint ø1/4" ø19mm	118-1949	
Snap-on ø7,3 ø16mm	118-1947	118-1919

Application notes

Provision for PE Grounding is located at the PE Stamp on the compressor

Model

Designation	SC12CNX.2	220-240V/50Hz	Conf. 1	Sales code:	104H8266
-------------	------------------	----------------------	----------------	-------------	-----------------

Configuration

Motorconfiguration	CSIR
Power supply (nominal)	220-240V/50Hz 1~
Refrigerant	R290
Application	LBP
Voltage range	198-254V
Starting torque	HST
Approvals	CCC VDE

Electrical accessories / wiring diagram

CSIR

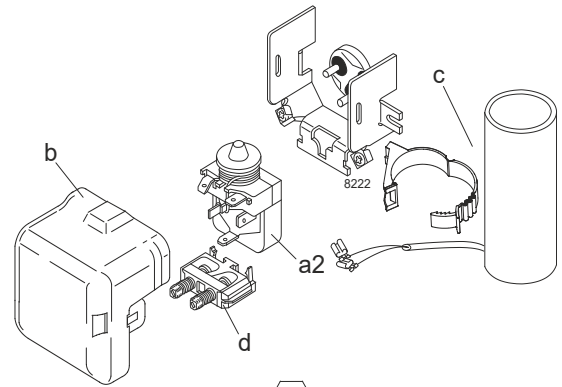

Ambient/ machine room temperatures minimum /maximum

Ambient temperature range:	10 - 43°C / 50 - 110°F
Machine room temperature range:	10 - 48°C / 50 - 119°F
Compressor cooling:	fan 3m/s

Operation Limits

Operation pressure range

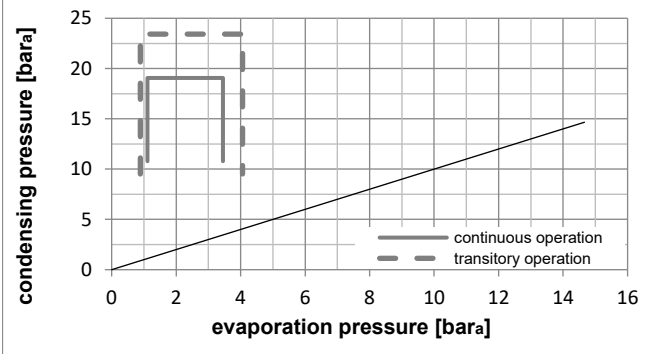
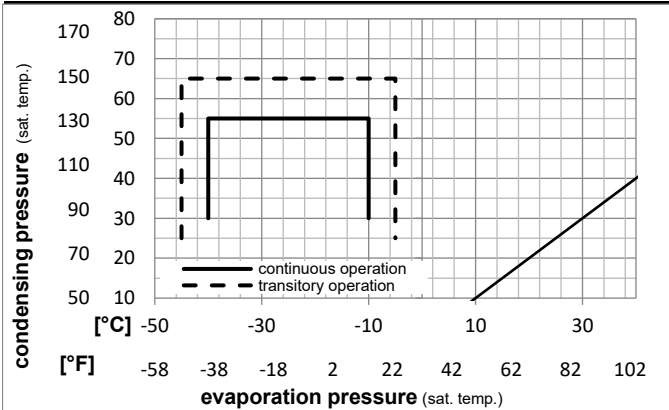

Components

a2	relay	117U7003
c	start capacitor (80μF)	117U5017
d	cord relief	103N1004
b	plastic cover	103N2009

Model

Designation **SC12CNX.2** **220-240V/50Hz** Conf. 1 Sales code: **104H8266**

Optimization + standard conditions

R290, 220V/50Hz, CSIR, fan 3m/s, CCC, VDE

		Evaporating pressure (saturation temperature)				Condensing pressure (saturation temperature)			Return gas temp.			Liquid temp.			Cooling capacity			COP	EER	Power consumption			
		pe	pc	RGT	Tliq	[W]	[Btu/h]	[kcal/h]	[W/W]	[Btu/Wh]	[kcal/Wh]	P1	I	Ref. mass flow	m								
[°C]	[°F]	[°C]	[°F]	[°C]	[°F]							[W]	[A]	[kg/h]									
-23	-10	54	130	32	90	489,6	1672	421,4	1,19	4,08	1,03	409,8	2,43	4,96								ASHRAE LBP	
-25	-13	55	131	32	90	359,3	1227	309,2	0,91	3,12	0,79	393,7	2,37	4,47								cecomaf LBP	
-35	-31	40	104	20	68	279,4	954	240,4	0,96	3,26	0,82	292,5	2,06	3,19								EN12900 LBP	
-23	-10	49	120	4,4	40	414,2	1415	356,5	1,03	3,52	0,89	401,5	2,42	5,74								ARI540 LBP	
-23	-10	41	105	32	90	569,6	1945	490,2	1,50	5,13	1,29	379,2	2,35	5,77								AHAM LBP	
-35	-31	45	113	32	90	258,1	882	222,1	0,87	2,95	0,74	298,3	2,09	2,89								opt	

Performance tables

R290, 220V/50Hz, CSIR, fan 3m/s, CCC, VDE

	pe		Cooling capacity			COP	EER	P1	I	m	
	[°C]	[°F]	[W]	[Btu/h]	[kcal/h]	[W/W]	[Btu/Wh]	[kcal/Wh]	[W]	[A]	[kg/h]
[°C / °F]	-40	-40	186,3	636	160,3	0,72	2,47	0,62	257,4	1,99	2,08
cond. pressure	-35	-31	258,1	882	222,1	0,87	2,95	0,74	298,3	2,09	2,89
pc= 45/113	-30	-22	346,3	1183	298,1	1,02	3,49	0,88	338,7	2,21	3,89
return gas temp.	-25	-13	452,5	1545	389,4	1,19	4,08	1,03	378,8	2,35	5,10
RGT= 32/90	-20	-4	578,3	1975	497,6	1,38	4,71	1,19	419,2	2,50	6,55
liquid temp	-15	5	725,1	2476	624,0	1,58	5,38	1,36	460,2	2,67	8,25
Tliq= 45/113	-10	14	894,6	3055	769,9	1,78	6,08	1,53	502,4	2,86	10,23
[°C / °F]	-40	-40	115,1	393	99,0	0,49	1,66	0,42	236,3	1,94	1,42
cond. pressure	-35	-31	183,5	627	157,9	0,63	2,15	0,54	291,0	2,07	2,27
pc= 55/131	-30	-22	264,4	903	227,5	0,77	2,63	0,66	343,3	2,21	3,28
return gas temp	-25	-13	359,3	1227	309,2	0,91	3,12	0,79	393,7	2,37	4,47
RGT= 32/90	-20	-4	469,8	1605	404,3	1,06	3,62	0,91	442,7	2,55	5,88
liquid temp	-15	5	597,5	2041	514,2	1,22	4,16	1,05	490,5	2,75	7,51
Tliq= 55/131	-10	14	743,9	2541	640,2	1,38	4,73	1,19	537,7	2,96	9,41



SC Compressors





SC Compressors

Service/Repair – R290



8545



Secop accepts no responsibility for possible errors in catalogs, brochures, and other printed material. Secop reserves the right to alter its products without notice. This also applies to products already on order provided that such alterations can be made without subsequent changes being necessary to specifications already agreed. All trademarks in this material are the property of the respective companies. Secop and the Secop logotype are trademarks of Secop GmbH. All rights reserved. www.secop.com