

## Single Pack NL6F 220-240V 50Hz RSIR

Codice Imballo Singolo: **195B4205**

Posizione	Titolo	Codice	Quantità
1	Compressor NL6F	105G6606	1
2	PTC starting device (220V, 250hm, 6.3mm)	103N0011	1
3	Protection screen for PTC	103N0476	1
4	Cord relief	103N1010	1
5	Cover	103N2010	1
6	Bolt joint for one compressor   M6   ø16mm	118-1917	1

**Secop GmbH** • Lise-Meitner-Straße 29 • 24941 Flensburg, Germany • Tel: +49 46149410 • [www.secop.com](http://www.secop.com)

Secop non si assume alcuna responsabilità per eventuali errori presenti in cataloghi, brochure e altro materiale stampato. Secop si riserva il diritto di modificare i propri prodotti senza preavviso. Ciò vale anche per i prodotti già ordinati, a condizione che tali modifiche possano essere apportate senza che siano necessarie modifiche successive alle specifiche già concordate. Tutti i marchi presenti in questo materiale sono di proprietà delle rispettive aziende. Secop e il logo Secop sono marchi di Secop GmbH. Tutti i diritti sono riservati.

## Model

Designation	<b>NL6F</b>	220-240V/50Hz 1~	Sales code:	<b>105G6606</b>
-------------	-------------	------------------	-------------	-----------------

## Compressor design

Oil type	Polyolester	Refrigerant(s)	<b>R134a</b>
Oil viscosity	19,2cST	Displacement	6,13cm <sup>3</sup> / 0,37cu.in
Oil quantity	265cm <sup>3</sup> / 9fl.oz	Compressors on pallet	80
Refr. charge - tech. limit	400g / 14,1oz		
Free gas volume comp.	2130cm <sup>3</sup> / 72fl.oz		
Weight	9,3kg / 20,5lbs		
Motor protection	1# internal		
Winding resistance main	16Ω (at 25°C)		
Winding resistance aux	13,6Ω (at 25°C)		
Max. winding temp.	125°C / 257°F		
Max. discharge temp.	130°C / 266°F		



## General - Configurations with NL6F

	<b>Conf. 1</b>	<b>Conf. 2</b>
Motorconfiguration	RSIR	CSIR
Power supply (nominal)	220-240V/50Hz	220-240V/50Hz
Number of phases	1	1
Voltage range	198-254V	198-254V
Approvals	VDE, EAC	VDE, EAC
Starting torque	LST	HST
Note	- / -	

## Applications with NL6F

	<b>Conf. 1</b>	<b>Conf. 2</b>
Refrigerant	R134a	R134a
Application	LBP	LBP
System cooling	static	static
Hot gas defrost	- / -	- / -
Long interval pull down	- / -	- / -

## Electrical data - Configurations with NL6F

	<b>Conf. 1</b>	<b>Conf. 2</b>
Starting device type	PTC	relay
Run capacitor	- / -	- / -
Start capacitor	- / -	80μF
LRA (locked rotor amps / 4s)	5A	5A
RLA (rated load amps / 1s)	1A	1A
Cut in current	9,6A	9,6A

## Model

Designation

**NL6F**

220-240V/50Hz 1~

Sales code:

**105G6606**

## Compressor dimensions

Housing	A Height	187,5mm / 7,38in
	B Height	181,5mm / 7,15in
	C Length shell	205mm / 8,07in
	D Length w. cover	254mm / 10in
	E Width	166mm / 6,54in

Connectors		Suction	Discharge	Process
		X	Y	Z
Diameter	[mm]	øi 6,11-6,29	øi 5,12-5,22	øi 6,11-6,29
	(i:inside, o:outside) [in]	øi 0,24-0,25	øi 0,2-0,21	øi 0,24-0,25
Material		copper	copper	copper
Horizontal angle	±2°	0°	0°	0°
Vertical angle	±2°	15°	35°	155°
Position l/h/w	[mm]	126/76/78	133/103/54	-107/94/72
	[in]	4,9/3/3,1	5,2/4/2,1	-4,2/3,7/2,8
Straight tube l.	[mm]	12	12	12
	[in]	0,5	0,5	0,5

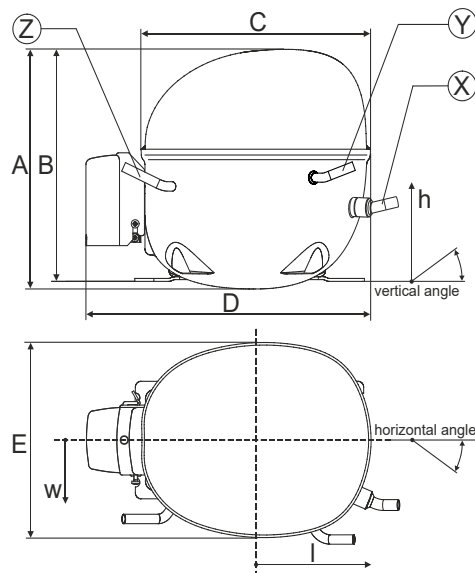

## Compressor fixation

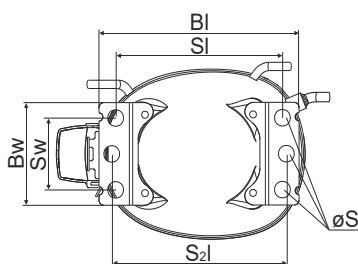

Baseplate	[mm]	[inch]
BI	204	8.03
Bw	100	3.94
Small holes	[mm]	[inch]
SI	170	6.7
Sw	70	2.76
S2l	178	7
øS	ø 16	ø 0.63

## Bolt joint

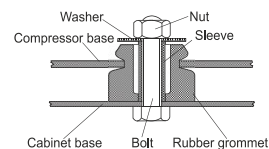

## Snap-on



## Mounting accessories

	one comp.	multi pack
Bolt joint   M6   ø16mm	118-1917	118-1918
Bolt joint   ø1/4"   ø16mm	118-1946	
Bolt joint   ø1/4"   ø19mm	118-1949	
Snap-on   ø7,3   ø16mm	118-1947	118-1919

## Model

Designation	<b>NL6F</b>	<b>220-240V/50Hz</b>	<b>Conf. 1</b>	Sales code:	<b>105G6606</b>
-------------	-------------	----------------------	----------------	-------------	-----------------

## Configuration

Motorconfiguration	RSIR
Power supply (nominal)	220-240V/50Hz 1~
Refrigerant	R134a
Application	LBP
Voltage range	198-254V
Starting torque	LST
Approvals	VDE
	EAC

## Electrical accessories / wiring diagram

RSIR

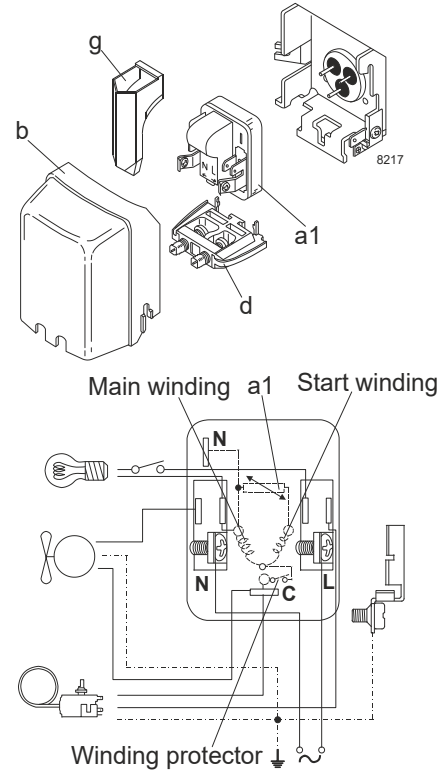

## Ambient temperatures / system cooling

Ambient temperature min.:	10°C / 50°F
Ambient temperature max.:	38°C / 101°F

System cooling (n/a: outside limits)			
T ambient	LBP	MBP	HBP
32°C / 90°F	static	n/a	n/a
38°C / 100°F	static	n/a	n/a
43°C / 110°F	n/a	n/a	n/a

## Operation pressure range

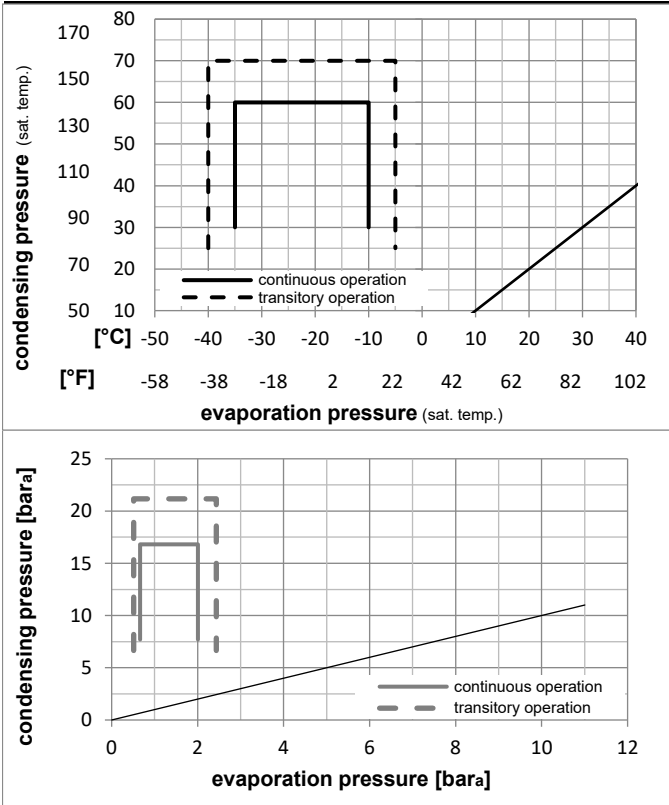

## Components

a1	PTC starter (220V, 250hm, 4.8mm)	103N0018
b	plastic cover	103N2010
d	cord relief	103N1010
g	protection screen for PTC	103N0476

## Alternative components

a1	PTC starter (220V, 250hm, 6.3mm)	103N0011
b	plastic cover	103N2011
d	cord relief	103N1010
g	protection screen for PTC	103N0476

## Model

Designation	<b>NL6F</b>	<b>220-240V/50Hz</b>	<b>Conf. 1</b>	Sales code:	<b>105G6606</b>
-------------	-------------	----------------------	----------------	-------------	-----------------

## Optimization + standard conditions

R134a, 220V/50Hz, RSIR, static, VDE, EAC

	Evaporating pressure (saturation temperature)				Condensing pressure (saturation temperature)			Return gas temp.	Liquid temp.	Cooling capacity	COP	EER	Power consumption			Ref. mass flow	
	pe	pc	RGT	Tliq	[W]	[Btu/h]	[kcal/h]						P1	I	m		
[°C]	[°F]	[°C]	[°F]	[°C]	[°F]	[°C]	[°F]	[W]	[Btu/h]	[kcal/h]	[W/W]	[Btu/Wh]	[kcal/Wh]	[W]	[A]	[kg/h]	
-23	54	32	32	151,6	518	130,5	1,21	4,15	1,05	124,8	0,88	2,94	ASHRAE LBP				
-10	130	90	90														
-25	55	32	55	110,0	376	94,7	0,93	3,19	0,80	117,9	0,86	2,63	cecomaf LBP				
-13	131	90	131														
-35	40	20	40	67,9	232	58,4	0,78	2,66	0,67	87,2	0,80	1,49	EN12900 LBP				
-31	104	68	104														
-23	49	4,4	49	125,0	427	107,6	1,00	3,41	0,86	125,1	0,87	3,30	ARI540 LBP				
-10	120	40	120														
-23	41	32	32	173,3	592	149,1	1,41	4,83	1,22	122,5	0,87	3,36	AHAM LBP				
-10	105	90	90														
-35	45	32	45	62,1	212	53,4	0,72	2,47	0,62	85,9	0,79	1,34	opt				
-31	113	90	113														

## Performance tables

R134a, 220V/50Hz, RSIR, static, VDE, EAC

	pe		Cooling capacity			COP	EER	P1	I	m	
	[°C]	[°F]	[W]	[Btu/h]	[kcal/h]	[W/W]	[Btu/Wh]	[kcal/Wh]	[W]	[A]	[kg/h]
[°C / °F]	-35	-31	62,1	212	53,4	0,72	2,47	0,62	85,9	0,79	1,34
cond. pressure	-30	-22	93,7	320	80,6	0,92	3,15	0,79	101,4	0,81	2,02
pc= 45/113	-25	-13	133,0	454	114,4	1,13	3,84	0,97	118,2	0,85	2,88
return gas temp.	-23	-10	148,1	506	127,5	1,19	4,07	1,03	124,2	0,87	3,21
RGT= 32/90	-20	-4	180,2	616	155,1	1,32	4,51	1,14	136,3	0,90	3,92
liquid temp	-15	5	235,9	805	203,0	1,51	5,16	1,30	156,2	0,97	5,14
Tliq= 45/113	-10	14	300,1	1025	258,3	1,69	5,76	1,45	177,8	1,04	6,57
[°C / °F]	-35	-31	52,0	177	44,7	0,65	2,22	0,56	80,1	0,78	1,24
cond. pressure	-30	-22	77,2	264	66,4	0,78	2,68	0,67	98,4	0,81	1,84
pc= 55/131	-25	-13	110,0	376	94,7	0,93	3,19	0,80	117,9	0,86	2,63
return gas temp	-23	-10	123,0	420	105,9	0,99	3,37	0,85	124,8	0,88	2,94
RGT= 32/90	-20	-4	150,9	515	129,9	1,09	3,72	0,94	138,7	0,92	3,62
liquid temp	-15	5	200,1	683	172,2	1,24	4,24	1,07	161,0	0,99	4,82
Tliq= 55/131	-10	14	257,9	881	222,0	1,39	4,76	1,20	185,1	1,08	6,24

## Model

Designation	<b>NL6F</b>	<b>220-240V/50Hz</b>	<b>Conf. 2</b>	Sales code:	<b>105G6606</b>
-------------	-------------	----------------------	----------------	-------------	-----------------

## Configuration

Motorconfiguration	CSIR
Power supply (nominal)	220-240V/50Hz 1~
Refrigerant	R134a
Application	LBP
Voltage range	198-254V
Starting torque	HST
Approvals	VDE
	EAC

## Electrical accessories / wiring diagram

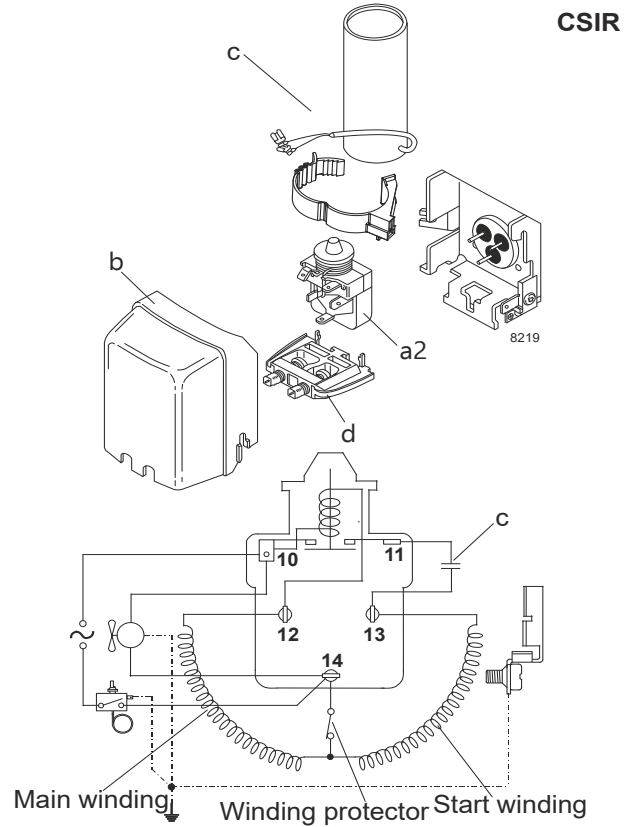

## Ambient temperatures / system cooling

Ambient temperature min.:	10°C / 50°F
Ambient temperature max.:	38°C / 101°F

System cooling (n/a: outside limits)			
T ambient	LBP	MBP	HBP
32°C / 90°F	static	n/a	n/a
38°C / 100°F	static	n/a	n/a
43°C / 110°F	n/a	n/a	n/a

## Operation pressure range

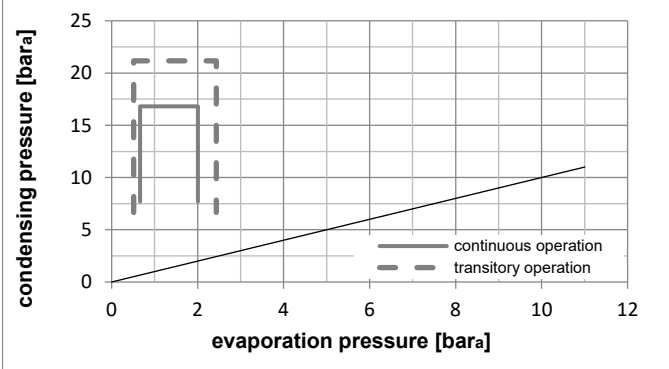
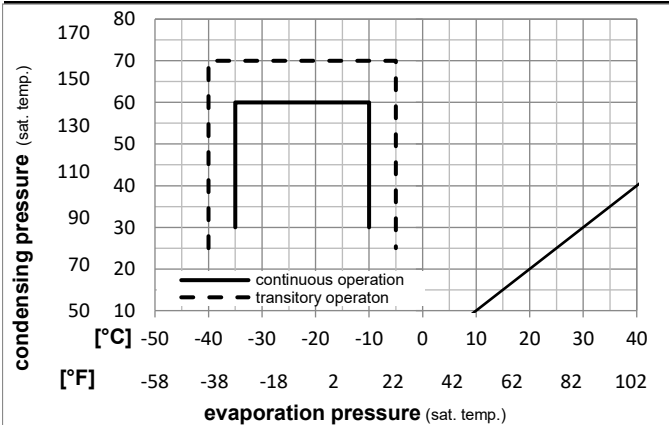

## Components

a2	current relay	117U6004
c	start capacitor (60μF)	117U5014
d	cord relief	103N1010
d	cord relief	103N1010

## Alternative components

b	plastic cover	103N2011
---	---------------	----------

## Model

Designation	<b>NL6F</b>	<b>220-240V/50Hz</b>	<b>Conf. 2</b>	Sales code:	<b>105G6606</b>
-------------	-------------	----------------------	----------------	-------------	-----------------

## Optimization + standard conditions

R134a, 220V/50Hz, CSIR, static, VDE, EAC

	Evaporating pressure (saturation temperature)				Condensing pressure (saturation temperature)			Return gas temp.	Liquid temp.	Cooling capacity	COP	EER	Power consumption			Ref. mass flow	
	pe	pc	RGT	Tliq	[W]	[Btu/h]	[kcal/h]						P1	I	m		
[°C]	[°F]	[°C]	[°F]	[°C]	[°F]	[°C]	[°F]	[W]	[Btu/h]	[kcal/h]	[W/W]	[Btu/Wh]	[kcal/Wh]	[W]	[A]	[kg/h]	
-23	54	32	32	151,6	518	130,5	1,21	4,15	1,05	124,8	0,88	2,94	ASHRAE LBP				
-10	130	90	90														
-25	55	32	55	110,0	376	94,7	0,93	3,19	0,80	117,9	0,86	2,63	cecomaf LBP				
-13	131	90	131														
-35	40	20	40	67,9	232	58,4	0,78	2,66	0,67	87,2	0,80	1,49	EN12900 LBP				
-31	104	68	104														
-23	49	4,4	49	125,0	427	107,6	1,00	3,41	0,86	125,1	0,87	3,30	ARI540 LBP				
-10	120	40	120														
-23	41	32	32	173,3	592	149,1	1,41	4,83	1,22	122,5	0,87	3,36	AHAM LBP				
-10	105	90	90														
-35	45	32	45	62,1	212	53,4	0,72	2,47	0,62	85,9	0,79	1,34	opt				
-31	113	90	113														

## Performance tables

R134a, 220V/50Hz, CSIR, static, VDE, EAC

	pe		Cooling capacity			COP	EER	P1	I	m	
	[°C]	[°F]	[W]	[Btu/h]	[kcal/h]	[W/W]	[Btu/Wh]	[kcal/Wh]	[W]	[A]	[kg/h]
[°C / °F]	-35	-31	62,1	212	53,4	0,72	2,47	0,62	85,9	0,79	1,34
cond. pressure	-30	-22	93,7	320	80,6	0,92	3,15	0,79	101,4	0,81	2,02
pc= 45/113	-25	-13	133,0	454	114,4	1,13	3,84	0,97	118,2	0,85	2,88
return gas temp.	-23	-10	148,1	506	127,5	1,19	4,07	1,03	124,2	0,87	3,21
RGT= 32/90	-20	-4	180,2	616	155,1	1,32	4,51	1,14	136,3	0,90	3,92
liquid temp	-15	5	235,9	805	203,0	1,51	5,16	1,30	156,2	0,97	5,14
Tliq= 45/113	-10	14	300,1	1025	258,3	1,69	5,76	1,45	177,8	1,04	6,57
[°C / °F]	-35	-31	52,0	177	44,7	0,65	2,22	0,56	80,1	0,78	1,24
cond. pressure	-30	-22	77,2	264	66,4	0,78	2,68	0,67	98,4	0,81	1,84
pc= 55/131	-25	-13	110,0	376	94,7	0,93	3,19	0,80	117,9	0,86	2,63
return gas temp	-23	-10	123,0	420	105,9	0,99	3,37	0,85	124,8	0,88	2,94
RGT= 32/90	-20	-4	150,9	515	129,9	1,09	3,72	0,94	138,7	0,92	3,62
liquid temp	-15	5	200,1	683	172,2	1,24	4,24	1,07	161,0	0,99	4,82
Tliq= 55/131	-10	14	257,9	881	222,0	1,39	4,76	1,20	185,1	1,08	6,24



# NL Compressors







## Service/Repair – R600a, R290

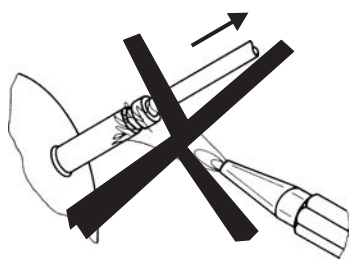

8545

## Brazing on Suction Connectors (Direct Intake)

representative image



**! max. 150°C/302°F !  
at socket**  
brazing solder: phosphor (LP7) or silver

Refer to Product Bulletin:  
**Brazing on Suction Connectors  
(Compressors with Direct Suction Intake)**

Secop accepts no responsibility for possible errors in catalogs, brochures, and other printed material. Secop reserves the right to alter its products without notice. This also applies to products already on order provided that such alterations can be made without subsequential changes being necessary to specifications already agreed. All trademarks in this material are the property of the respective companies. Secop and the Secop logotype are trademarks of Secop GmbH. All rights reserved. [www.secop.com](http://www.secop.com)