

## Single Pack BD220CL 12V DC PM

Codice Imballo Singolo: **195B4214**

Posizione	Titolo	Codice	Quantità
1	Compressor BD220CL	102Z3020	1
2	Electronic unit 12V DC	101N0830	1
3	Bolt joint for one compressor   M6   $\varnothing$ 16mm	118-1917	1

**Secop GmbH** • Lise-Meitner-Straße 29 • 24941 Flensburg, Germany • Tel: +49 46149410 • [www.secop.com](http://www.secop.com)

Secop non si assume alcuna responsabilità per eventuali errori presenti in cataloghi, brochure e altro materiale stampato. Secop si riserva il diritto di modificare i propri prodotti senza preavviso. Ciò vale anche per i prodotti già ordinati, a condizione che tali modifiche possano essere apportate senza che siano necessarie modifiche successive alle specifiche già concordate. Tutti i marchi presenti in questo materiale sono di proprietà delle rispettive aziende. Secop e il logo Secop sono marchi di Secop GmbH. Tutti i diritti sono riservati.

## BD220CL Direct Current Compressor R404A/R507 12V DC - with 101N08xx Series Controllers

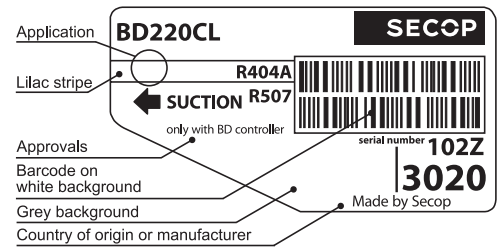

### General

Code number (without electronic units)	102Z3020
Compressor module	101N0800, 30 pcs: 101N0801
Application module	101N0820, 30 pcs: 101N0821
Alternative (one interface only): Electronic Unit (no fan connection/no twin option)	101N0830, 30 pcs: 101N0831
Approvals	-
Compressors on pallet	125

### Application

Application	LBP
Evaporating temperature °C	-45 to -5
Voltage range VDC	9.6 - 17
Max. condensing temperature continuous (short) °C	50 (60)
Max. winding temperature continuous (short) °C	125 (135)

### Cooling requirements

Application	LBP	MBP	HBP
32°C	F <sub>1</sub>	-	-
38°C	F <sub>1</sub>	-	-
43°C	F <sub>1</sub>	-	-

Remarks on application:  
- evaporator fan max. 200W  
- condenser fan max. 100W

### Motor

Motor type	variable speed
Resistance, all 3 windings (25°C) Ω	0.1

### Design

Displacement cm <sup>3</sup>	3.86
Oil quantity (type) cm <sup>3</sup>	280 (polyolester)
Maximum refrigerant charge g	400
Free gas volume in compressor cm <sup>3</sup>	1690
Weight - Compressor/Electronic unit kg	7.9 / 0.33 / 0.28 (101N820)

### Battery protection settings

Voltage	Min. value	Default	Max. value
Cut out (0.1 steps) VDC	9.6	10.4	17
Cut in diff. (0.1 steps) VDC	0.5	1.3	10

### Dimensions

Height	mm	A	173
		B	169
		B1	-
		B2	-
Suction connector	location/I.D. mm   angle	C	6.2   90°
	material   comment		Cu-plated steel   Al cap
Process connector	location/I.D. mm   angle	D	6.2   31.5°
	material   comment		Cu-plated steel   Al cap
Discharge connector	location/I.D. mm   angle	E	5.0   28°
	material   comment		Cu-plated steel   Al cap
Connector tolerance	I.D. mm		±0.09, on 5.0 +0.12/+0.20

- S = Static cooling normally sufficient
- O = Oil cooling
- F<sub>1</sub> = Fan cooling 1.5 m/s  
(compressor compartment temperature equal to ambient temperature)
- F<sub>2</sub> = Fan cooling 3.0 m/s necessary
- SG = Suction gas cooling normally sufficient
- = not applicable in this area

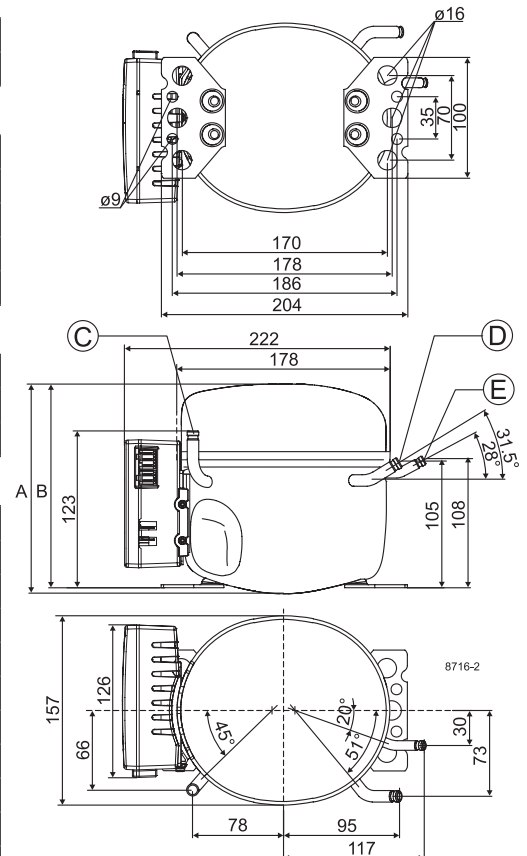

Capacity (EN 12900 Household/CECOMAF)												12V DC, fan cooling F <sub>1</sub>												watt
rpm \ °C	-45	-40	-35	-30	-25	-23.3	-20	-15	-10	-6.7	-5	0												
2,500	26.4	47.1	71.9	101	136	149	177	224	278	318	340													
3,000	31.4	56.0	85.5	121	162	178	210	266	331	379	405													
3,500	36.3	64.9	99.2	140	188	206	244	309	384	439	470													
4,000	40.8	73.1	112	158	212	232	275	349	433	495	530													

Capacity (ASHRAE LBP)												12V DC, fan cooling F <sub>1</sub>												watt
rpm \ °C	-45	-40	-35	-30	-25	-23.3	-20	-15	-10	-6.7	-5	0												
2,500	31	55	83	117	158	173	205	260	323	370	396													
3,000	36	65	99	140	188	206	244	310	385	441	472													
3,500	42	75	115	162	218	239	284	360	447	512	547													
4,000	47	85	130	183	246	270	320	405	504	577	617													

Power consumption												12V DC, fan cooling F <sub>1</sub>												watt
rpm \ °C	-45	-40	-35	-30	-25	-23.3	-20	-15	-10	-6.7	-5	0												
2,500	65.2	82.8	98.9	114	129	133	143	158	174	185	191													
3,000	75.2	96.0	115	134	152	158	170	190	210	225	233													
3,500	84.3	108	131	152	174	181	196	219	245	263	272													
4,000	94.3	121	147	172	197	206	223	251	281	303	314													

Current consumption												12V DC, fan cooling F <sub>1</sub>												A
rpm \ °C	-45	-40	-35	-30	-25	-23.3	-20	-15	-10	-6.7	-5	0												
2,500	5.43	6.90	8.24	9.50	10.71	11.12	11.92	13.16	14.48	15.40	15.90													
3,000	6.27	8.00	9.62	11.16	12.67	13.19	14.20	15.81	17.53	18.75	19.42													
3,500	7.03	9.02	10.89	12.69	14.48	15.10	16.32	18.27	20.38	21.89	22.71													
4,000	7.86	10.12	12.26	14.34	16.43	17.15	18.59	20.90	23.41	25.22	26.20													

COP (EN 12900 Household/CECOMAF)												12V DC, fan cooling F <sub>1</sub>												W/W
rpm \ °C	-45	-40	-35	-30	-25	-23.3	-20	-15	-10	-6.7	-5	0												
2,500	0.41	0.57	0.73	0.89	1.06	1.12	1.23	1.42	1.60	1.72	1.78													
3,000	0.42	0.58	0.74	0.90	1.07	1.12	1.23	1.40	1.57	1.68	1.74													
3,500	0.43	0.60	0.76	0.92	1.08	1.14	1.25	1.41	1.57	1.67	1.72													
4,000	0.43	0.60	0.76	0.92	1.08	1.13	1.23	1.39	1.54	1.64	1.68													

COP (ASHRAE LBP)												12V DC, fan cooling F <sub>1</sub>												W/W
rpm \ °C	-45	-40	-35	-30	-25	-23.3	-20	-15	-10	-6.7	-5	0												
2,500	0.47	0.66	0.84	1.03	1.23	1.30	1.43	1.65	1.86	2.00	2.07													
3,000	0.48	0.68	0.86	1.05	1.24	1.30	1.43	1.63	1.83	1.96	2.02													
3,500	0.50	0.69	0.88	1.07	1.26	1.32	1.45	1.64	1.83	1.95	2.01													
4,000	0.50	0.70	0.88	1.06	1.25	1.31	1.43	1.62	1.79	1.91	1.96													

Test conditions		EN 12900/CECOMAF	ASHRAE LBP
Condensing temperature		45°C	45°C
Ambient temperature		32°C	32°C
Suction gas temperature		32°C	32°C
Liquid temperature		no subcooling	32°C

Operational errors	
Error code	Error type
Can be read out in the software <b>TOOL4COOL®</b>	
6	<b>Thermostat failure</b> (If the NTC thermistor is short-circuit or has no connection, the electronic unit will enter manual mode).
5	<b>Thermal cut-out of electronic unit</b> (If the refrigeration system has been too heavily loaded, or if the ambient temperature is high, the electronic unit will run too hot).
4	<b>Minimum motor speed error</b> (If the refrigeration system is too heavily loaded, the motor cannot maintain minimum speed at approximately 1,850 rpm).
3	<b>Motor start error</b> (The rotor is blocked or the differential pressure in the refrigeration system is too high).
2	<b>Fan over-current cut-out</b> (The fan loads the electronic unit with too high current).
1	<b>Battery protection cut-out</b> (The voltage is outside the cut-out setting).

Accessories for BD220CL		
Mounting	Code number	
Bolt joint for one compressor	Ø: 16 mm	118-1917
Bolt joint in quantities	Ø: 16 mm	118-1918
Snap-on in quantities	Ø: 16 mm	118-1919

Electrical (cables, sensors, etc.)	Code number	
	Single pack	I - Pack
One Wire/LIN gateway communication cable	105N9501	-
Bluetooth® gateway communication cable	105N9502	-
Temperature sensor 470 mm	105N9612	105N9613, 200 pcs.
Temperature sensor 1000 mm	105N9614	105N9615, 100 pcs.
Temperature sensor 1500 mm	105N9616	105N9617, 100 pcs.
Comm. cable, 1500 mm	-	105N9553, 80 pcs.
Comm. cable, 3000 mm	-	105N9554, 45 pcs.
Display cable, 1500 mm	-	105N9557, 65 pcs.
Display cable, 3000 mm	-	105N9558, 35 pcs.

Not deliverable from Secop	
Slow-blow fuse compressor module	60A
Slow-blow fuse application module	30A
Main switch	rated to min. 100A

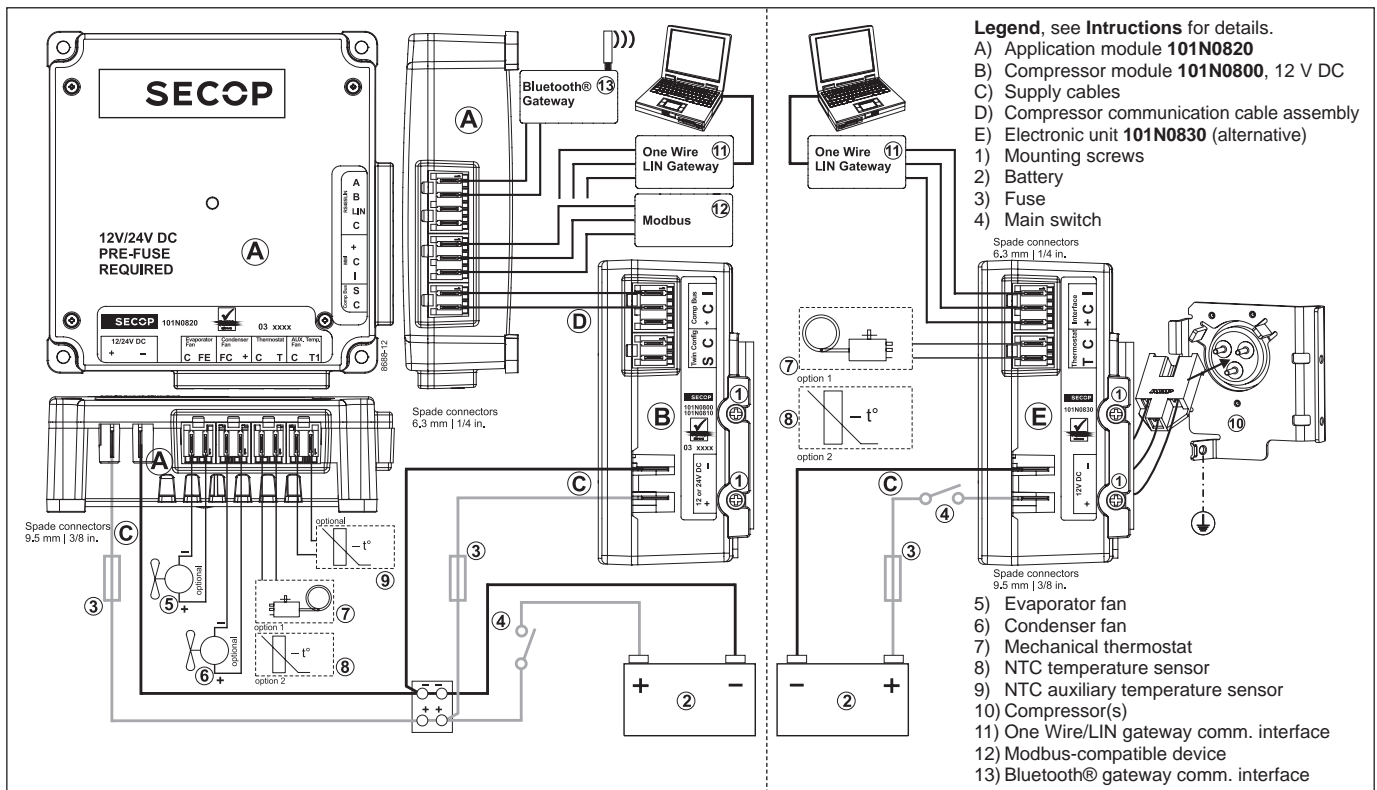

Secop accepts no responsibility for possible errors in catalogs, brochures, and other printed material. Secop reserves the right to alter its products without notice. This also applies to products already on order provided that such alterations can be made without consequential changes being necessary to specifications already agreed. All trademarks in this material are the property of the respective companies. Secop and the Secop logotype are trademarks of Secop GmbH. All rights reserved. [www.secop.com](http://www.secop.com)



Instructions for Electronic Units  
are available for download on  
[www.secop.com](http://www.secop.com)



# BD Compressors



## Service/Repair



### BD Nano



**! max. 150°C/302°F !  
at socket**  
brazing solder: silver with flux

Do not heat up the bottom of the discharge  
connector directly.  
Do not braze longer than 10 seconds and  
wait for 5 minutes for the next soldering  
attempt (Product Bulletin DES.N.101.M1).

### BD Micro

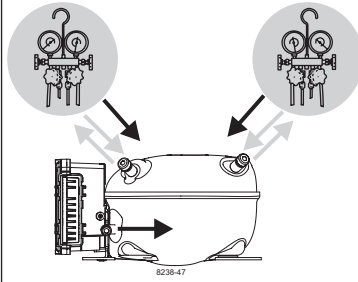

### BD P-Housing



### BD T-Housing



Secop accepts no responsibility for possible errors in catalogs, brochures, and other printed material. Secop reserves the right to alter its products without notice. This also applies to products already on order provided that such alterations can be made without subsequential changes being necessary to specifications already agreed. All trademarks in this material are the property of the respective companies. Secop and the Secop logotype are trademarks of Secop GmbH. All rights reserved. [www.secop.com](http://www.secop.com)