

## Single Pack NL8.4FT 220-240V 50Hz RSIR

Codice Imballo Singolo: **195B4219**

Posizione	Titolo	Codice	Quantità
1	Compressor NL8.4FT	105G6865	1
2	PTC starting device (220V, 250hm, 4.8mm)	103N0018	1
3	Protection screen for PTC	103N0476	1
4	Cord relief	103N1010	1
5	Cover	103N2010	1
6	Bolt joint for one compressor   M6   ø16mm	118-1917	1

Secop GmbH • Lise-Meitner-Straße 29 • 24941 Flensburg, Germany • Tel: +49 46149410 • [www.secop.com](http://www.secop.com)

Secop non si assume alcuna responsabilità per eventuali errori presenti in cataloghi, brochure e altro materiale stampato. Secop si riserva il diritto di modificare i propri prodotti senza preavviso. Ciò vale anche per i prodotti già ordinati, a condizione che tali modifiche possano essere apportate senza che siano necessarie modifiche successive alle specifiche già concordate. Tutti i marchi presenti in questo materiale sono di proprietà delle rispettive aziende. Secop e il logo Secop sono marchi di Secop GmbH. Tutti i diritti sono riservati.

**Model**

Designation	<b>NL8.4FT</b>	<b>220-240V/50Hz 1~</b>	Sales code:	<b>105G6865</b>
-------------	----------------	-------------------------	-------------	-----------------

**Compressor design**

Oil type	Polyolester	Refrigerant(s)	<b>R134a</b>
Oil viscosity	32cST	Displacement	8,35cm <sup>3</sup> / 0,51cu.in
Oil quantity	268cm <sup>3</sup> / 9,1fl.oz	Compressors on pallet	80
Refr. charge - tech. limit	400g / 14,1oz		
Free gas volume comp.	2360cm <sup>3</sup> / 79,8fl.oz		
Weight	9,6kg / 21,2lbs		
Motor protection	1# internal		
Winding resistance main	10,6Ω (at 25°C)		
Winding resistance aux	18,1Ω (at 25°C)		
Max. winding temp.	125°C / 257°F		
Max. discharge temp.	130°C / 266°F		



**General - Configurations with NL8.4FT**

	<b>Conf. 1</b>	<b>Conf. 2</b>
Motorconfiguration	CSIR	RSIR
Power supply (nominal)	220-240V/50Hz	220-240V/50Hz
Number of phases	1	1
Voltage range	187-254V	187-254V
Approvals	VDE, CCC, EAC	VDE, CCC, EAC
Starting torque	HST	LST
Note	- / -	

**Applications with NL8.4FT**

	<b>Conf. 1</b>	<b>Conf. 2</b>
Refrigerant	R134a	R134a
Application	LBP	LBP
System cooling	static	static
Hot gas defrost	- / -	- / -
Long interval pull down	- / -	- / -

**Electrical data - Configurations with NL8.4FT**

	<b>Conf. 1</b>	<b>Conf. 2</b>
Starting device type	relay	PTC
Run capacitor	- / -	- / -
Start capacitor	80μF	- / -
LRA (locked rotor amps / 4s)	9,4A	7,5A
RLA (rated load amps / 1s)	1,4A	1,4A
Cut in current	11,6A	11,6A

**Model**

Designation	<b>NL8.4FT</b>	220-240V/50Hz 1~	Sales code:	<b>105G6865</b>
-------------	----------------	------------------	-------------	-----------------

**Compressor dimensions**

<b>Housing</b>	A Height	189,5mm / 7,46in
	B Height	183,5mm / 7,22in
	C Length shell	205mm / 8,07in
	D Length w. cover	254mm / 10in
	E Width	166mm / 6,54in

<b>Connectors</b>		<b>Suction</b>	<b>Discharge</b>	<b>Process</b>
		<b>X</b>	<b>Y</b>	<b>Z</b>
Diameter	[mm]	øi 6,11-6,29	øi 5,12-5,22	øi 6,11-6,29
	(i:inside, o:outside) [in]	øi 0,24-0,25	øi 0,2-0,21	øi 0,24-0,25
Material		copper	copper	copper
Horizontal angle	±2°	0°	0°	0°
Vertical angle	±2°	15°	35°	155°
Position l/h/w	[mm]	126/76/78	133/103/54	-107/94/72
	[in]	4,9/3/3,1	5,2/4/2,1	-4,2/3,7/2,8
Straight tube l.	[mm]	12	12	12
	[in]	0,5	0,5	0,5

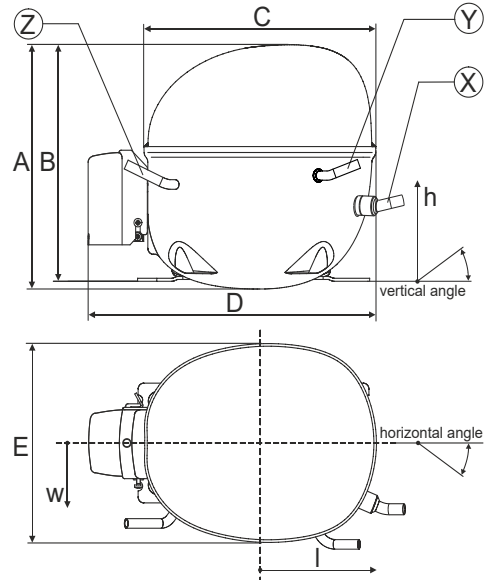

**Compressor fixation**

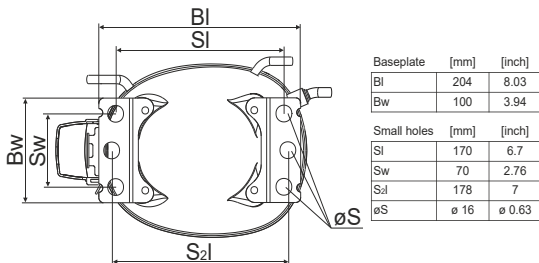

**Bolt joint**

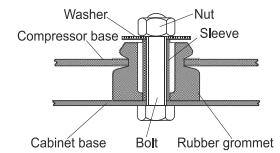

**Snap-on**

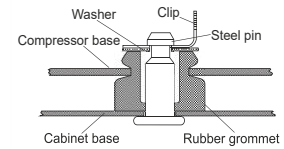

<b>Mounting accessories</b>	one comp.	multi pack
Bolt joint   M6   ø16mm	118-1917	118-1918
Bolt joint   ø1/4"   ø16mm	118-1946	
Bolt joint   ø1/4"   ø19mm	118-1949	
Snap-on   ø7,3   ø16mm	118-1947	118-1919

**Model**

Designation	<b>NL8.4FT</b>	<b>220-240V/50Hz</b>	<b>Conf. 1</b>	Sales code:	<b>105G6865</b>
-------------	----------------	----------------------	----------------	-------------	-----------------

**Configuration**

Motorconfiguration	CSIR
Power supply (nominal)	220-240V/50Hz 1~
Refrigerant	R134a
Application	LBP
Voltage range	187-254V
Starting torque	HST
Approvals	VDE
	CCC
	EAC

**Electrical accessories / wiring diagram**

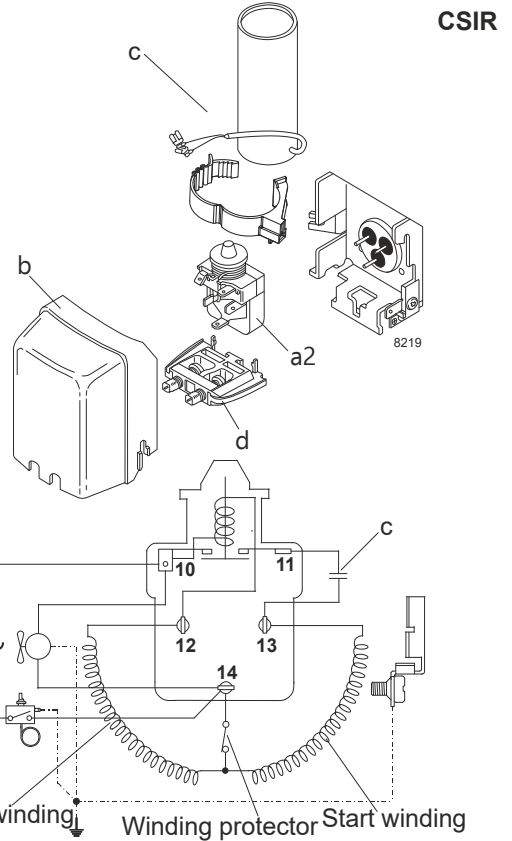

**Ambient temperatures / system cooling**

Ambient temperature min.:	10°C / 50°F
Ambient temperature max.:	43°C / 110°F

System cooling (n/a: outside limits)			
T ambient	LBP	MBP	HBP
32°C / 90°F	static	n/a	n/a
38°C / 100°F	fan 1,5m/s	n/a	n/a
43°C / 110°F	fan 1,5m/s	n/a	n/a

**Operation pressure range**

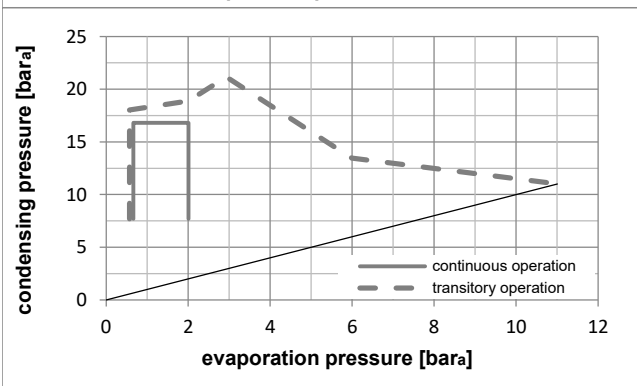
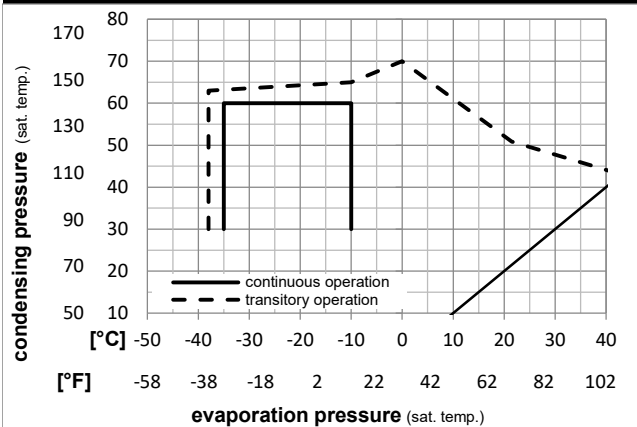

Components

a2	current relay	117U6001
c	start capacitor (80µF)	117U5015
b	plastic cover	103N2010
d	cord relief	103N1010

Alternative components

b	plastic cover	103N2011
---	---------------	----------

**Model**

Designation	<b>NL8.4FT</b>	<b>220-240V/50Hz</b>	<b>Conf. 1</b>	Sales code:	<b>105G6865</b>
-------------	----------------	----------------------	----------------	-------------	-----------------

**Optimization + standard conditions**

R134a, 220V/50Hz, CSIR, fan 1,5m/s, VDE, CCC, EAC

		Evaporating pressure (saturation temperature)				Condensing pressure (saturation temperature)						Power consumption					
						Return gas temp.						Current consumption					
						Liquid temp.						Ref. mass flow					
						Cooling capacity						COP	EER	P1	I	m	
		pe	pc	RGT	Tliq	[W]	[Btu/h]	[kcal/h]	[W/W]	[Btu/Wh]	[kcal/Wh]	[W]	[A]	[kg/h]			
[°C]	-23,3	54,4	32,2	32,2	219,1	748	188,6	1,23	4,21	1,06	177,9	1,30	4,25	ASHRAE LBP			
[°F]	-10	130	90	90													
[°C]	-25	55	32	55	161,6	552	139,0	0,95	3,26	0,82	169,5	1,28	3,86	cecomaf LBP			
[°F]	-13	131	89,6	131													
[°C]	-35	40	20	40	114,5	391	98,6	0,91	3,10	0,78	126,1	1,18	2,51	EN12900 LBP			
[°F]	-31	104	68	104													
[°C]	-23,3	48,9	4,44	48,9	180,3	616	155,1	1,02	3,48	0,88	176,9	1,30	4,76	ARI540 LBP			
[°F]	-10	120	40	120													
[°C]	-23,3	40,6	32,2	32,2	245,5	839	211,3	1,43	4,88	1,23	171,7	1,29	4,77	AHAM LBP			
[°F]	-10	105	90	90													
[°C]	-35	45	32	45	107,4	367	92,5	0,84	2,88	0,73	127,4	1,19	2,32	opt			
[°F]	-31	113	89,6	113													

**Performance tables**

R134a, 220V/50Hz, CSIR, fan 1,5m/s, VDE, CCC, EAC

	pe	Cooling capacity				COP	EER	P1	I	m	
	[°C]	[°F]	[W]	[Btu/h]	[kcal/h]	[W/W]	[Btu/Wh]	[kcal/Wh]	[W]	[A]	[kg/h]
[°C / °F]	-35	-31	107,4	367	92,5	0,84	2,88	0,73	127,4	1,19	2,32
cond. pressure	-30	-22	145,8	498	125,4	1,00	3,41	0,86	146,0	1,23	3,15
pc= 45/113	-25	-13	193,8	662	166,8	1,16	3,96	1,00	167,2	1,28	4,20
return gas temp.	-23,3	-10	212,6	726	183,0	1,22	4,15	1,05	174,8	1,30	4,61
RGT= 32/90	-20	-4	252,9	864	217,6	1,33	4,54	1,14	190,2	1,35	5,49
liquid temp	-15	5	324,2	1107	279,0	1,51	5,17	1,30	214,3	1,42	7,07
Tliq= 45/113	-10	14	409,1	1397	352,1	1,71	5,85	1,47	238,8	1,51	8,95
[°C / °F]	-35	-31	86,9	297	74,8	0,69	2,34	0,59	126,8	1,18	2,07
cond. pressure	-30	-22	120,0	410	103,3	0,82	2,80	0,71	146,4	1,22	2,86
pc= 55/131	-25	-13	161,6	552	139,0	0,95	3,26	0,82	169,5	1,28	3,86
return gas temp	-23,3	-10	177,9	607	153,1	1,00	3,41	0,86	177,9	1,30	4,26
RGT= 32/90	-20	-4	212,9	727	183,2	1,09	3,73	0,94	195,2	1,36	5,11
liquid temp	-15	5	275,3	940	236,9	1,24	4,22	1,06	222,8	1,45	6,63
Tliq= 55/131	-10	14	349,9	1195	301,1	1,39	4,75	1,20	251,6	1,55	8,46

**Model**

Designation	<b>NL8.4FT</b>	<b>220-240V/50Hz</b>	<b>Conf. 2</b>	Sales code:	<b>105G6865</b>
-------------	----------------	----------------------	----------------	-------------	-----------------

**Configuration**

Motorconfiguration	RSIR
Power supply (nominal)	220-240V/50Hz 1~
Refrigerant	R134a
Application	LBP
Voltage range	187-254V
Starting torque	LST
Approvals	VDE CCC EAC

**Electrical accessories / wiring diagram**

RSIR

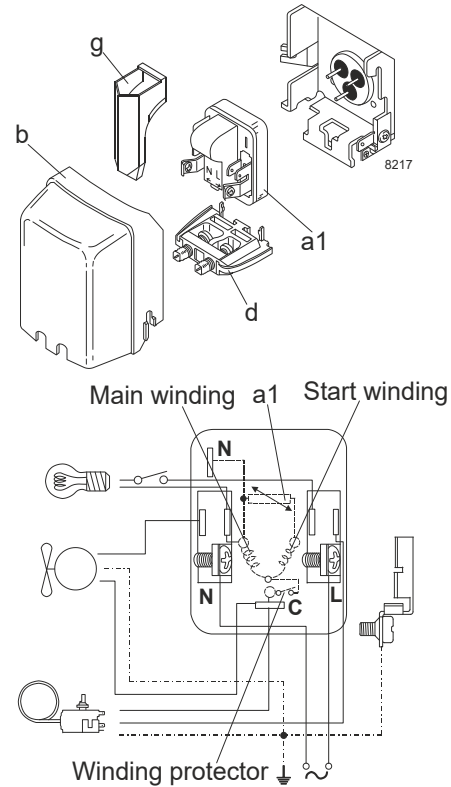

**Ambient temperatures / system cooling**

Ambient temperature min.:	10°C / 50°F
Ambient temperature max.:	43°C / 110°F

System cooling (n/a: outside limits)			
T ambient	LBP	MBP	HBP
32°C / 90°F	static	n/a	n/a
38°C / 100°F	fan 1,5m/s	n/a	n/a
43°C / 110°F	fan 1,5m/s	n/a	n/a

**Operation pressure range**

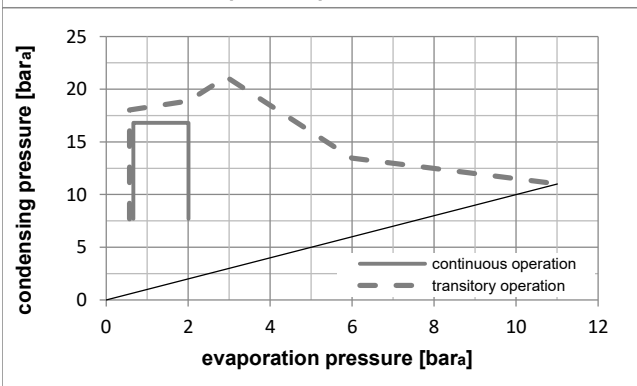
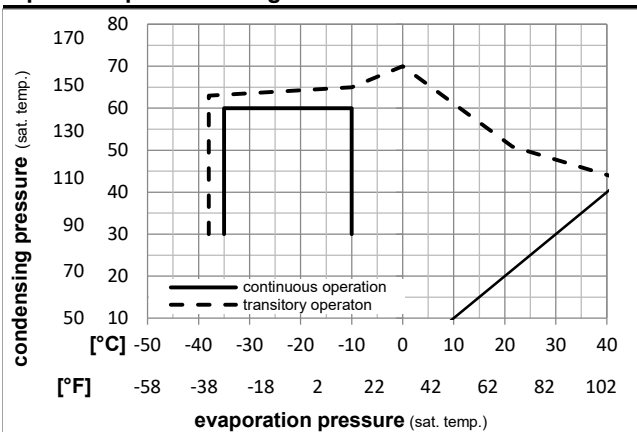

Components

a1	PTC starter (220V, 250hm, 4.8mm)	103N0018
b	plastic cover	103N2010
d	cord relief	103N1010
g	protection screen for PTC	103N0476

Alternative components

a1	PTC starter (220V, 250hm, 6.3mm)	103N0011
b	plastic cover	103N2011
d	cord relief	103N1010
g	protection screen for PTC	103N0476

**Model**

Designation	<b>NL8.4FT</b>	<b>220-240V/50Hz</b>	<b>Conf. 2</b>	Sales code:	<b>105G6865</b>
-------------	----------------	----------------------	----------------	-------------	-----------------

**Optimization + standard conditions**

R134a, 220V/50Hz, RSIR, fan 1,5m/s, VDE, CCC, EAC

		Evaporating pressure (saturation temperature)			Condensing pressure (saturation temperature)			Return gas temp.		Liquid temp.		Cooling capacity			COP	EER	Power consumption			Ref. mass flow m	
		pe	pc	RGT	Tliq	[W]	[Btu/h]	[kcal/h]	[W/W]	[Btu/Wh]	[kcal/Wh]	P1	I	Current consumption							
[°C]	[°F]											[W]	[A]	[kg/h]							
[°C]	-23	54,4	32,2	32,2	219,1	748	188,6	1,23	4,21	1,06	177,9	1,30	4,25	ASHRAE							
[°F]	-10	130	90	90										LBP							
[°C]	-25	55	32	55	161,6	552	139,0	0,95	3,26	0,82	169,5	1,28	3,86	cecomaf							
[°F]	-13	131	89,6	131										LBP							
[°C]	-35	40	20	40	114,5	391	98,6	0,91	3,10	0,78	126,1	1,18	2,51	EN12900							
[°F]	-31	104	68	104										LBP							
[°C]	-23	48,9	4,44	48,9	180,3	616	155,1	1,02	3,48	0,88	176,9	1,30	4,76	ARI540							
[°F]	-10	120	40	120										LBP							
[°C]	-23	40,6	32,2	32,2	245,5	839	211,3	1,43	4,88	1,23	171,7	1,29	4,77	AHAM							
[°F]	-10	105	90	90										LBP							
[°C]	-35	45	32	45	107,4	367	92,5	0,84	2,88	0,73	127,4	1,19	2,32	opt							
[°F]	-31	113	89,6	113																	

**Performance tables**

R134a, 220V/50Hz, RSIR, fan 1,5m/s, VDE, CCC, EAC

	pe		Cooling capacity			COP	EER	P1	I	m	
	[°C]	[°F]	[W]	[Btu/h]	[kcal/h]	[W/W]	[Btu/Wh]	[kcal/Wh]	[W]	[A]	[kg/h]
[°C / °F]	-35	-31	107,4	367	92,5	0,84	2,88	0,73	127,4	1,19	2,32
cond. pressure	-30	-22	145,8	498	125,4	1,00	3,41	0,86	146,0	1,23	3,15
pc= 45/113	-25	-13	193,8	662	166,8	1,16	3,96	1,00	167,2	1,28	4,20
return gas temp.	-23	-10	212,6	726	183,0	1,22	4,15	1,05	174,8	1,30	4,61
RGT= 32/90	-20	-4	252,9	864	217,6	1,33	4,54	1,14	190,2	1,35	5,49
liquid temp	-15	5	324,2	1107	279,0	1,51	5,17	1,30	214,3	1,42	7,07
Tliq= 45/113	-10	14	409,1	1397	352,1	1,71	5,85	1,47	238,8	1,51	8,95
[°C / °F]	-35	-31	86,9	297	74,8	0,69	2,34	0,59	126,8	1,18	2,07
cond. pressure	-30	-22	120,0	410	103,3	0,82	2,80	0,71	146,4	1,22	2,86
pc= 55/131	-25	-13	161,6	552	139,0	0,95	3,26	0,82	169,5	1,28	3,86
return gas temp	-23	-10	177,9	607	153,1	1,00	3,41	0,86	177,9	1,30	4,26
RGT= 32/90	-20	-4	212,9	727	183,2	1,09	3,73	0,94	195,2	1,36	5,11
liquid temp	-15	5	275,3	940	236,9	1,24	4,22	1,06	222,8	1,45	6,63
Tliq= 55/131	-10	14	349,9	1195	301,1	1,39	4,75	1,20	251,6	1,55	8,46



8238-20

# NL Compressors

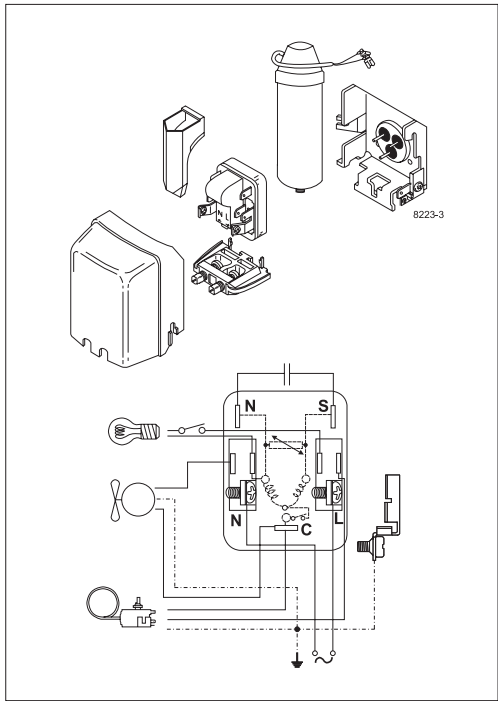
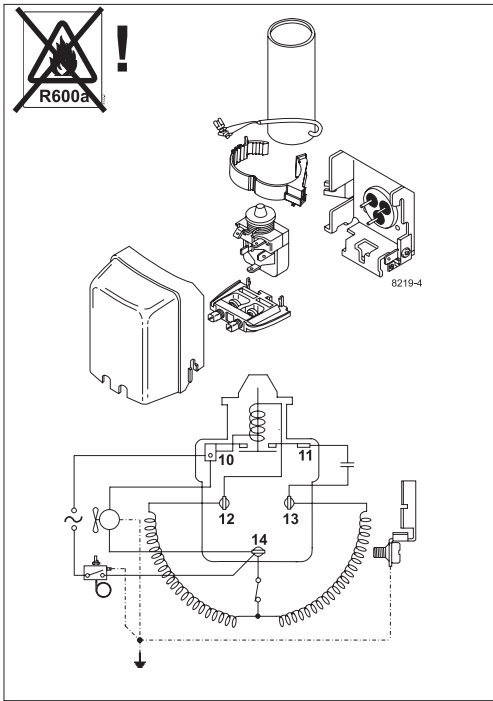
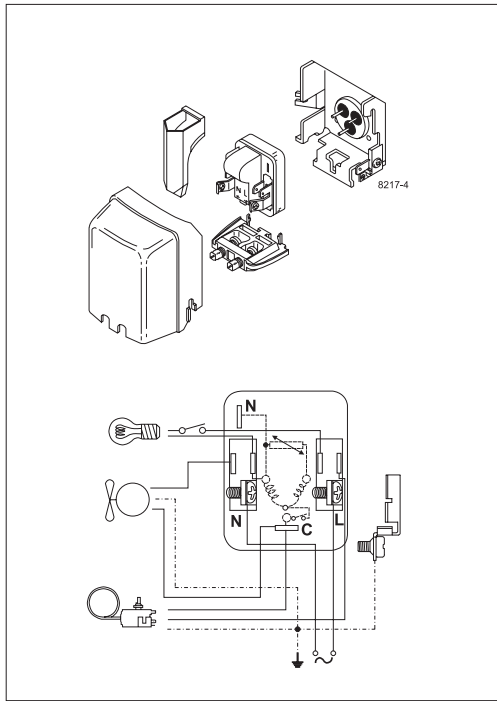





## Service/Repair – R600a, R290

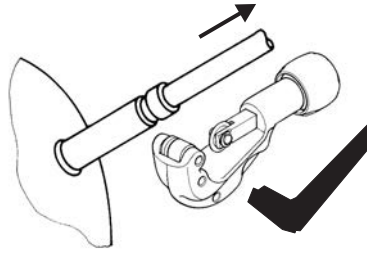
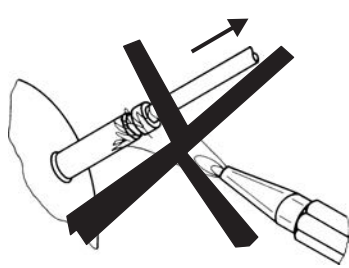

8545

## Brazing on Suction Connectors (Direct Intake)

representative image



**! max. 150°C/302°F !  
at socket**  
brazing solder: phosphor (LP7) or silver

Refer to Product Bulletin:  
**Brazing on Suction Connectors  
(Compressors with Direct Suction Intake)**

Secop accepts no responsibility for possible errors in catalogs, brochures, and other printed material. Secop reserves the right to alter its products without notice. This also applies to products already on order provided that such alterations can be made without subsequential changes being necessary to specifications already agreed. All trademarks in this material are the property of the respective companies. Secop and the Secop logotype are trademarks of Secop GmbH. All rights reserved. [www.secop.com](http://www.secop.com)