

Single Pack SC12GH 220-240V 50Hz / 208-230V 60Hz CSIR

Codice Imballo Singolo: **195B4222**

Posizione	Titolo	Codice	Quantità
1	Compressor SC12GH	104G8261	1
2	Starting relay	117U6011	1
3	Starting capacitor (80 μ F 220V, 6.3mm)	117U5017	1
4	Cord relief	103N1004	1
5	Cover	103N2008	1
6	Bolt joint for one compressor M6 \varnothing 16mm	118-1917	1

Secop GmbH • Lise-Meitner-Straße 29 • 24941 Flensburg, Germany • Tel: +49 46149410 • www.secop.com

Secop non si assume alcuna responsabilità per eventuali errori presenti in cataloghi, brochure e altro materiale stampato. Secop si riserva il diritto di modificare i propri prodotti senza preavviso. Ciò vale anche per i prodotti già ordinati, a condizione che tali modifiche possano essere apportate senza che siano necessarie modifiche successive alle specifiche già concordate. Tutti i marchi presenti in questo materiale sono di proprietà delle rispettive aziende. Secop e il logo Secop sono marchi di Secop GmbH. Tutti i diritti sono riservati.

Model

Designation	SC12GH	220-240V/50Hz 1~ 208-230V/60Hz 1~	Sales code:	104G8261
-------------	---------------	--	-------------	-----------------

Compressor design

Oil type	Polyolester	Refrigerant(s)	R134a, R513A
Oil viscosity	22cST	Displacement	12,87cm ³ / 0,79cu.in
Oil quantity	504cm ³ / 17fl.oz	Compressors on pallet	80
Refr. charge - tech. limit	1300g / 45,9oz		
Free gas volume comp.	1510cm ³ / 51,1fl.oz		
Weight	12,5kg / 27,6lbs		
Motor protection	1# internal		
Winding resistance main	4,4Ω (at 25°C)		
Winding resistance aux	14Ω (at 25°C)		
Max. winding temp.	125°C / 257°F		
Max. discharge temp.	130°C / 266°F		



General - Configurations with SC12GH

	Conf. 1	Conf. 2	Conf. 3	Conf. 4
Motorconfiguration	CSIR	CSIR	CSIR	CSIR
Power supply (nominal)	220-240V/50Hz	220-240V/50Hz	208-230V/60Hz	208-230V/60Hz
Number of phases	1	1	1	1
Voltage range	198-254V	198-254V	198-254V	198-254V
Approvals	VDE, UL, KC	VDE, UL	VDE, UL, KC	VDE, UL
Starting torque	HST	HST	HST	HST
Note	- / -			

Applications with SC12GH

	Conf. 1	Conf. 2	Conf. 3	Conf. 4
Refrigerant	R134a	R513A	R134a	R513A
Application	HBP	HBP	HBP	HBP
System cooling	fan 3m/s	fan 3m/s	fan 3m/s	fan 3m/s
Hot gas defrost	OK	OK	OK	OK
Long interval pull down	OK	OK	OK	OK

Electrical data - Configurations with SC12GH

	Conf. 1	Conf. 2	Conf. 3	Conf. 4
Starting device type	relay	relay	relay	relay
Run capacitor	-/-	-/-	-/-	-/-
Start capacitor	80μF	80μF	80μF	80μF
LRA (locked rotor amps / 4s)	19A	19A	18,3A	18,3A
RLA (rated load amps / 1s)	3,9A	3,9A	3,52A	3,52A
Cut in current	19A	19A	18,3A	18,3A

Model

Designation **SC12GH** 220-240V/50Hz 1~ 208-230V/60Hz 1~ Sales code: **104G8261**

Compressor dimensions

Housing	A Height	209mm / 8,23in
	B Height	203mm / 7,99in
	C Length shell	218mm / 8,58in
	D Length w. cover	255mm / 10,04in
	E Width	151mm / 5,94in

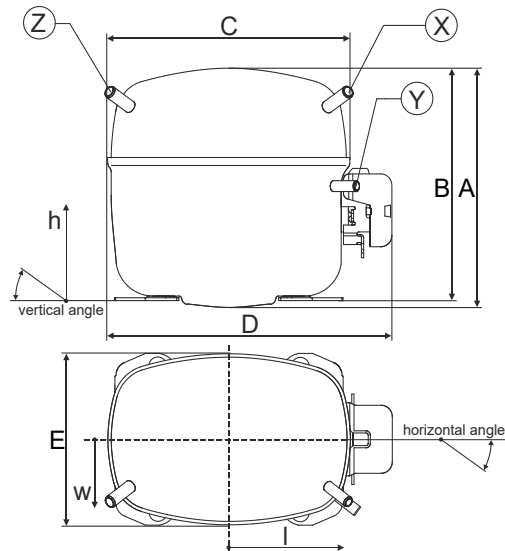

Connectors	Suction		Discharge		Process	
	X		Y		Z	
Diameter [mm]	øi 10,11-10,29		øi 8,11-8,29		øi 6,11-6,29	
(i:inside, o:outside) [in]	øi 0,4-0,41		øi 0,32-0,33		øi 0,24-0,25	
Material	copper		copper		copper	
Horizontal angle ±2°	37°		37°		143°	
Vertical angle ±2°	30°		0°		150°	
Position l/h/w [mm]	107/183/55		115/100/63		-107/183/55	
[in]	4,2/7,2/2,2		4,5/3,9/2,5		-4,2/7,2/2,2	
Straight tube l. [mm]	12		12		12	
[in]	0,5		0,5		0,5	

Compressor fixation

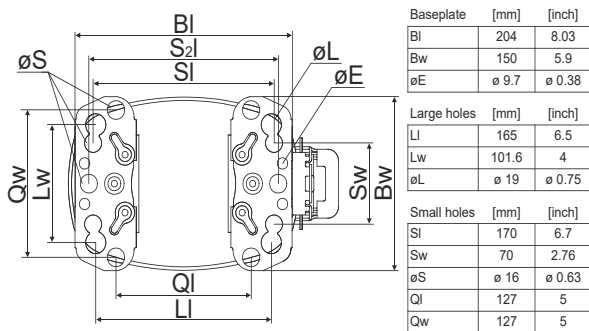

Bolt joint

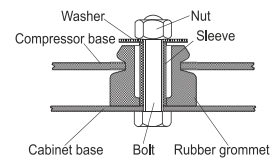

Snap-on

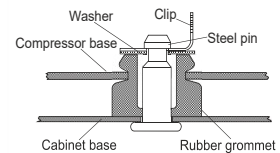

Mounting accessories	one comp.	multi pack
Bolt joint M6 ø16mm	118-1917	118-1918
Bolt joint ø1/4" ø16mm	118-1946	
Bolt joint ø1/4" ø19mm	118-1949	
Snap-on ø7,3 ø16mm	118-1947	118-1919

Application notes

Provision for PE Grounding is located at the PE Stamp on the compressor

Model

Designation	SC12GH	220-240V/50Hz	Conf. 1	Sales code:	104G8261
-------------	---------------	----------------------	---------	-------------	-----------------

Configuration

Motorconfiguration	CSIR
Power supply (nominal)	220-240V/50Hz 1~
Refrigerant	R134a
Application	HBP
Voltage range	198-254V
Starting torque	HST
Approvals	VDE
	UL
	KC

Electrical accessories / wiring diagram

CSIR

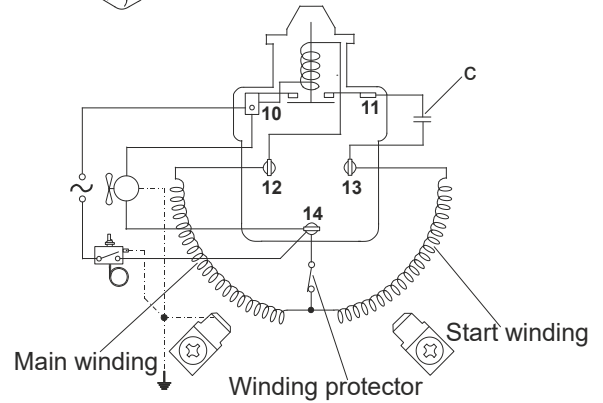
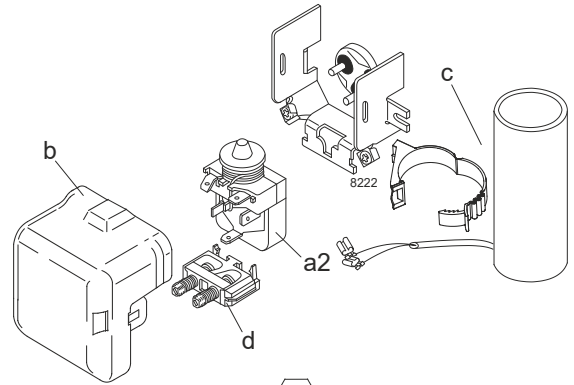

Ambient/ machine room temperatures minimum /maximum

Ambient temperature range: 10 - 43°C / 50 - 110°F

Machine room temperature range: 10 - 48°C / 50 - 119°F

Compressor cooling: fan 3m/s

Operation Limits

Operation pressure range

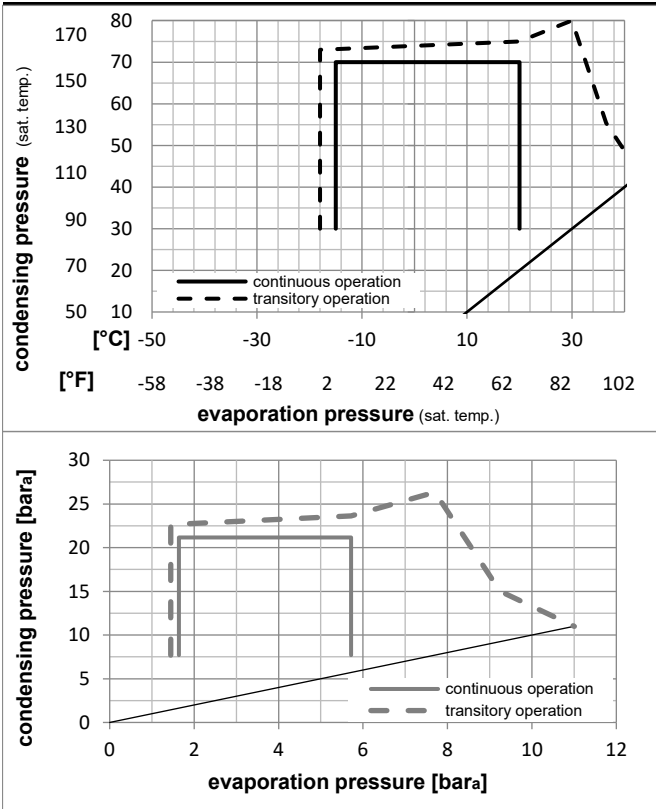

Components

a2	relay	117U6011
c	start capacitor (80µF)	117U5017
d	cord relief	103N1004
b	plastic cover	103N2008

Model

Designation **SC12GH** **220-240V/50Hz** Conf. 1 Sales code: **104G8261**

Optimization + standard conditions

R134a, 220V/50Hz, CSIR, fan 3m/s, VDE, UL, KC

Evaporating pressure (saturation temperature)				Condensing pressure (saturation temperature)			Return gas temp.			Liquid temp.			Cooling capacity			COP	EER	Power consumption		
pe	pc	RGT	Tliq	[W]	[Btu/h]	[kcal/h]	[W/W]	[Btu/Wh]	[kcal/Wh]	P1	I	Ref. mass flow								
[°C]	[°C]	[°C]	[°C]	[W]	[Btu/h]	[kcal/h]	[W/W]	[Btu/Wh]	[kcal/Wh]	[W]	[A]	[kg/h]								
7,2	54	35	46	1175,9	4016	1012,0	2,34	8,00	2,02	501,9	3,52	26,09	ASHRAE HBP							
[°F]	[°F]	[°F]	[°F]																	
45	130	95	115																	
5	55	32	55	957,3	3269	823,9	1,97	6,71	1,69	487,1	3,47	23,59	cecomaf HBP							
[°C]	[°C]	[°C]	[°C]																	
[°F]	[°F]	[°F]	[°F]																	
41	131	90	131																	
5	50	20	50	998,2	3409	859,0	2,15	7,34	1,85	464,7	3,39	25,15	EN12900 HBP							
[°C]	[°C]	[°C]	[°C]																	
[°F]	[°F]	[°F]	[°F]																	
41	122	68	122																	
-7	54	35	46	583,7	1994	502,4	1,52	5,18	1,30	385,2	3,16	12,74	ASHRAE MBP							
[°C]	[°C]	[°C]	[°C]																	
[°F]	[°F]	[°F]	[°F]																	
20	130	95	115																	
-10	55	32	55	428,7	1464	368,9	1,20	4,11	1,04	356,3	3,08	10,37	cecomaf MBP							
[°C]	[°C]	[°C]	[°C]																	
[°F]	[°F]	[°F]	[°F]																	
14	131	90	131																	
-10	45	20	45	517,8	1768	445,7	1,49	5,08	1,28	348,4	3,06	12,12	EN12900 MBP							
[°C]	[°C]	[°C]	[°C]																	
[°F]	[°F]	[°F]	[°F]																	
14	113	68	113																	

Performance tables

R134a, 220V/50Hz, CSIR, fan 3m/s, VDE, UL, KC

	pe		Cooling capacity			COP	EER		P1	I	m
	[°C]	[°F]	[W]	[Btu/h]	[kcal/h]	[W/W]	[Btu/Wh]	[kcal/Wh]	[W]	[A]	[kg/h]
[°C / °F]	-15	5	395,5	1351	340,3	1,27	4,33	1,09	312,2	2,98	8,62
cond. pressure	-10	14	537,2	1835	462,4	1,54	5,27	1,33	348,4	3,06	11,76
pc= 45/113	-5	23	704,5	2406	606,3	1,84	6,28	1,58	383,3	3,14	15,49
return gas temp.	0	32	901,0	3077	775,4	2,17	7,40	1,87	415,7	3,23	19,92
RGT= 32/90	5	41	1130,2	3860	972,7	2,54	8,69	2,19	444,3	3,31	25,16
liquid temp	15	59	1701,6	5811	1464,4	3,51	11,98	3,02	485,3	3,47	38,54
Tliq= 45/113	20	68	2051,1	7005	1765,2	4,14	14,14	3,56	495,3	3,55	46,98
[°C / °F]	-15	5	302,4	1033	260,3	0,97	3,31	0,83	312,0	2,94	7,28
cond. pressure	-10	14	428,7	1464	368,9	1,20	4,11	1,04	356,3	3,08	10,37
pc= 55/131	-5	23	577,5	1972	497,0	1,44	4,92	1,24	401,0	3,21	14,04
return gas temp	0	32	752,5	2570	647,6	1,69	5,77	1,46	445,0	3,34	18,41
RGT= 32/90	5	41	957,3	3269	823,9	1,97	6,71	1,69	487,1	3,47	23,59
liquid temp	15	59	1471,0	5024	1265,9	2,62	8,96	2,26	560,6	3,73	36,95
Tliq= 55/131	20	68	1787,1	6103	1538,0	3,03	10,35	2,61	589,6	3,86	45,44

Model

Designation	SC12GH	220-240V/50Hz	Conf. 2	Sales code:	104G8261
-------------	---------------	----------------------	---------	-------------	-----------------

Configuration

Motorconfiguration	CSIR
Power supply (nominal)	220-240V/50Hz 1~
Refrigerant	R513A
Application	HBP
Voltage range	198-254V
Starting torque	HST
Approvals	VDE UL

Electrical accessories / wiring diagram

CSIR

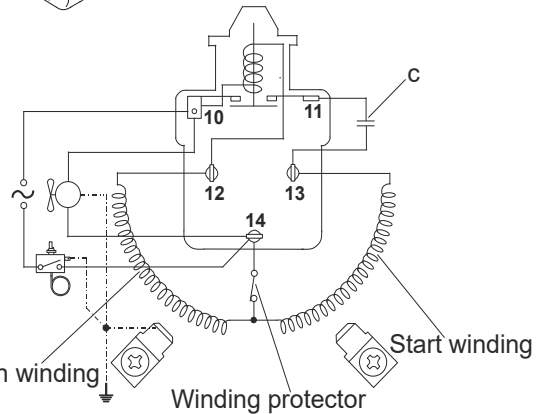
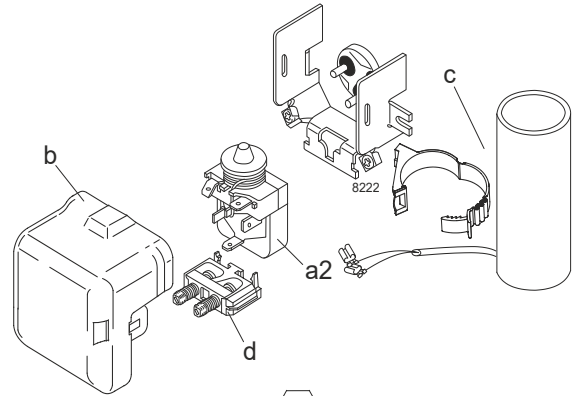

Ambient/ machine room temperatures minimum /maximum

Ambient temperature range: 10 - 43°C / 50 - 110°F

Machine room temperature range: 10 - 48°C / 50 - 119°F

Compressor cooling: fan 3m/s

Operation Limits

Operation pressure range

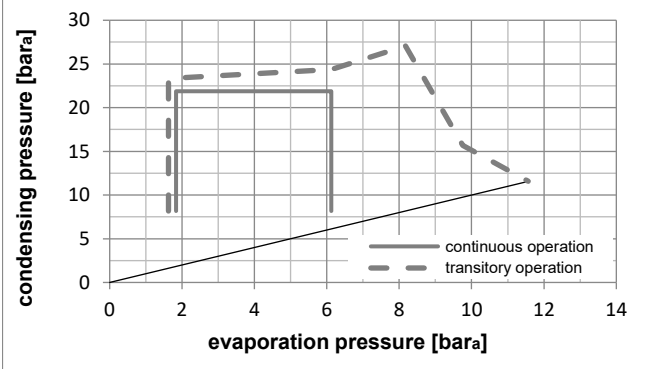
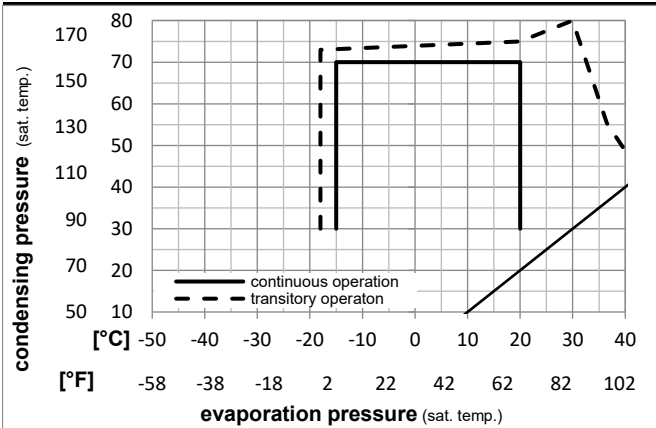

Components

a2	relay	117U6011
c	start capacitor (80µF)	117U5017
d	cord relief	103N1004
b	plastic cover	103N2008

Model

Designation	SC12GH	220-240V/50Hz	Conf. 2	Sales code:	104G8261
-------------	---------------	----------------------	----------------	-------------	-----------------

Optimization + standard conditions

R513A, 220V/50Hz, CSIR, fan 3m/s, VDE, UL

		Evaporating pressure (saturation temperature)				Condensing pressure (saturation temperature)						Power consumption			
		Return gas temp.		Liquid temp.		Cooling capacity		COP	EER		P1	I	Ref. mass flow		
		pe	pc	RGT	Tliq	[W]	[Btu/h]	[kcal/h]	[W/W]	[Btu/Wh]	[kcal/Wh]	[W]	[A]	[kg/h]	
[°C]	7,2	54	35	46	1210,2	4133	1041,5	2,31	7,90	1,99	522,9	3,59	30,06	ASHRAE HBP	
[°F]	45	130	95	115											
[°C]	5	55	32	55	970,8	3316	835,5	1,91	6,52	1,64	508,5	3,54	27,28	cecomaf HBP	
[°F]	41	131	90	131											
[°C]	5	50	20	50	1013,9	3463	872,6	2,09	7,14	1,80	484,8	3,47	29,07	EN12900 HBP	
[°F]	41	122	68	122											
[°C]	-7	54	35	46	613,9	2097	528,4	1,51	5,16	1,30	406,7	3,23	15,04	ASHRAE MBP	
[°F]	20	130	95	115											
[°C]	-10	55	32	55	445,8	1523	383,7	1,18	4,03	1,02	377,6	3,14	12,33	cecomaf MBP	
[°F]	14	131	90	131											
[°C]	-10	45	20	45	542,1	1852	466,6	1,47	5,03	1,27	368,3	3,11	14,37	EN12900 MBP	
[°F]	14	113	68	113											

Performance tables

R513A, 220V/50Hz, CSIR, fan 3m/s, VDE, UL

	pe		Cooling capacity			COP	EER		P1	I	m
	[°C]	[°F]	[W]	[Btu/h]	[kcal/h]	[W/W]	[Btu/Wh]	[kcal/Wh]	[W]	[A]	[kg/h]
[°C / °F]	-15	5	421,5	1440	362,8	1,27	4,34	1,09	331,5	2,99	10,33
cond. pressure	-10	14	566,9	1936	487,9	1,54	5,26	1,32	368,3	3,11	13,94
pc= 45/113	-5	23	737,1	2517	634,3	1,83	6,24	1,57	403,3	3,22	18,19
return gas temp.	0	32	935,4	3195	805,0	2,15	7,34	1,85	435,4	3,31	23,20
RGT= 32/90	5	41	1165,5	3980	1003,0	2,52	8,59	2,16	463,3	3,40	29,07
liquid temp	15	59	1734,6	5924	1492,8	3,45	11,80	2,97	502,2	3,52	43,89
Tliq= 45/113	20	68	2080,5	7105	1790,5	4,07	13,91	3,50	510,9	3,55	53,12
[°C / °F]	-15	5	318,2	1087	273,8	0,96	3,27	0,82	332,4	3,00	8,76
cond. pressure	-10	14	445,8	1523	383,7	1,18	4,03	1,02	377,6	3,14	12,33
pc= 55/131	-5	23	594,8	2031	511,9	1,41	4,81	1,21	422,7	3,28	16,52
return gas temp	0	32	768,7	2625	661,5	1,65	5,62	1,42	466,8	3,41	21,47
RGT= 32/90	5	41	970,8	3316	835,5	1,91	6,52	1,64	508,5	3,54	27,28
liquid temp	15	59	1473,9	5034	1268,5	2,54	8,67	2,19	580,5	3,76	42,09
Tliq= 55/131	20	68	1781,8	6085	1533,4	2,93	10,00	2,52	608,5	3,85	51,41

Model

Designation	SC12GH	208-230V/60Hz	Conf. 3	Sales code:	104G8261
-------------	---------------	----------------------	----------------	-------------	-----------------

Configuration

Motorconfiguration	CSIR
Power supply (nominal)	208-230V/60Hz 1~
Refrigerant	R134a
Application	HBP
Voltage range	198-254V
Starting torque	HST
Approvals	VDE
	UL
	KC

Electrical accessories / wiring diagram

CSIR

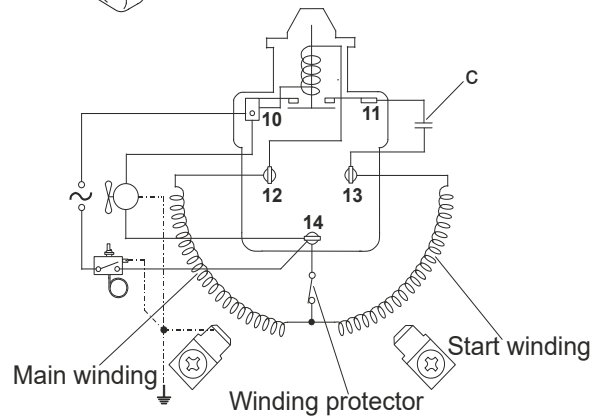
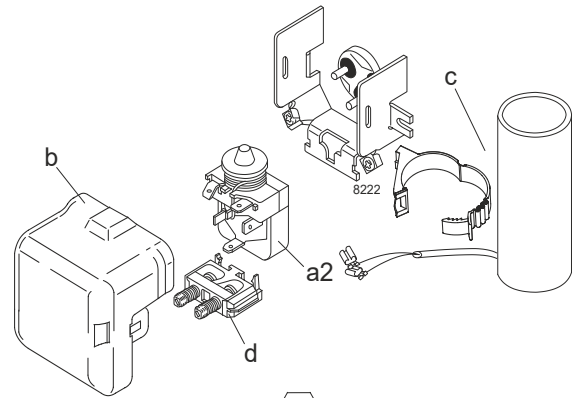

Ambient/ machine room temperatures minimum /maximum

Ambient temperature range: 10 - 43°C / 50 - 110°F

Machine room temperature range: 10 - 48°C / 50 - 119°F

Compressor cooling: fan 3m/s

Operation Limits

Operation pressure range

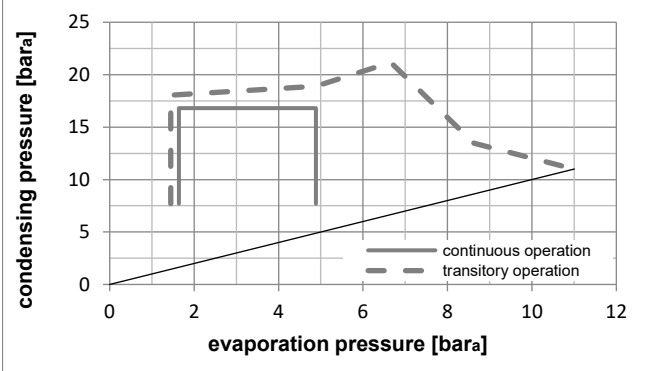
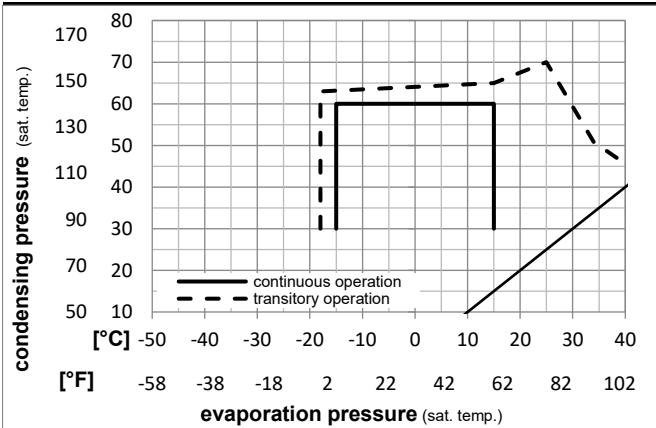

Components

a2	relay	117U6011
c	start capacitor (80µF)	117U5017
d	cord relief	103N1004
b	plastic cover	103N2008

Model

Designation **SC12GH** **208-230V/60Hz** Conf. 3 Sales code: **104G8261**

Optimization + standard conditions

R134a, 230V/60Hz, CSIR, fan 3m/s, VDE, UL, KC

		Evaporating pressure (saturation temperature)				Condensing pressure (saturation temperature)						Power consumption			
		Return gas temp.		Liquid temp.		Cooling capacity		COP	EER		P1	I	Ref. mass flow		
		pe	pc	RGT	Tliq	[W]	[Btu/h]	[kcal/h]	[W/W]	[Btu/Wh]	[kcal/Wh]	[W]	[A]	[kg/h]	
[°C]	7,2	54	35	46	1370,3	4680	1179,3	2,38	8,13	2,05	575,7	3,36	30,40	ASHRAE HBP	
[°F]	45	130	95	115											
[°C]	5	55	32	55	1116,4	3813	960,8	2,01	6,86	1,73	555,8	3,28	27,51	cecomaf HBP	
[°F]	41	131	90	131											
[°C]	5	50	20	50	1163,6	3974	1001,4	2,20	7,53	1,90	528,0	3,16	29,32	EN12900 HBP	
[°F]	41	122	68	122											
[°C]	-7	54	35	46	688,4	2351	592,4	1,62	5,53	1,39	425,5	2,76	15,02	ASHRAE MBP	
[°F]	20	130	95	115											
[°C]	-10	55	32	55	511,2	1746	440,0	1,31	4,49	1,13	388,9	2,61	12,36	cecomaf MBP	
[°F]	14	131	90	131											
[°C]	-10	45	20	45	608,8	2079	523,9	1,61	5,49	1,38	378,9	2,57	14,25	EN12900 MBP	
[°F]	14	113	68	113											

Performance tables

R134a, 230V/60Hz, CSIR, fan 3m/s, VDE, UL, KC

	pe		Cooling capacity			COP	EER		P1	I	m
	[°C]	[°F]	[W]	[Btu/h]	[kcal/h]	[W/W]	[Btu/Wh]	[kcal/Wh]	[W]	[A]	[kg/h]
[°C / °F]	-15	5	469,7	1604	404,2	1,41	4,80	1,21	334,0	2,39	10,24
cond. pressure	-10	14	631,6	2157	543,5	1,67	5,69	1,43	378,9	2,57	13,82
pc= 45/113	-5	23	824,5	2816	709,6	1,95	6,67	1,68	422,3	2,74	18,13
return gas temp.	0	32	1052,5	3594	905,8	2,27	7,75	1,95	463,8	2,90	23,28
RGT= 32/90	5	41	1319,7	4507	1135,7	2,62	8,96	2,26	502,8	3,05	29,38
liquid temp	10	50	1630,1	5567	1402,9	3,03	10,34	2,60	538,6	3,19	36,58
Tliq= 45/113	15	59	1987,8	6789	1710,7	3,48	11,90	3,00	570,6	3,33	45,03
[°C / °F]	-15	5	371,0	1267	319,3	1,12	3,81	0,96	332,3	2,37	8,93
cond. pressure	-10	14	511,2	1746	440,0	1,31	4,49	1,13	388,9	2,61	12,36
pc= 55/131	-5	23	679,5	2321	584,8	1,53	5,21	1,31	445,5	2,84	16,52
return gas temp	0	32	879,9	3005	757,2	1,76	5,99	1,51	501,3	3,06	21,52
RGT= 32/90	5	41	1116,4	3813	960,8	2,01	6,86	1,73	555,8	3,28	27,51
liquid temp	10	50	1393,1	4758	1199,0	2,29	7,82	1,97	608,3	3,49	34,63
Tliq= 55/131	15	59	1714,2	5854	1475,3	2,60	8,89	2,24	658,4	3,68	43,06

Model

Designation	SC12GH	208-230V/60Hz	Conf. 4	Sales code:	104G8261
-------------	---------------	----------------------	---------	-------------	-----------------

Configuration

Motorconfiguration	CSIR
Power supply (nominal)	208-230V/60Hz 1~
Refrigerant	R513A
Application	HBP
Voltage range	198-254V
Starting torque	HST
Approvals	VDE UL

Electrical accessories / wiring diagram

CSIR

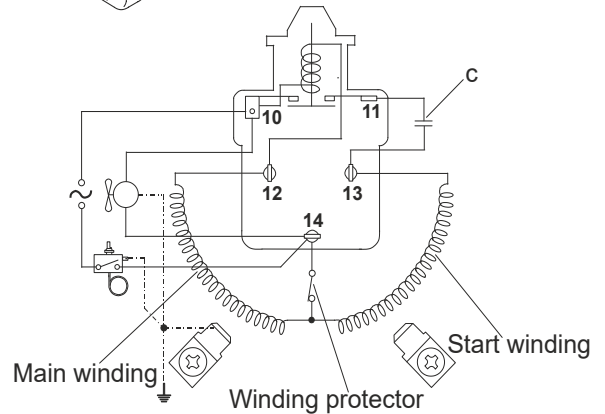
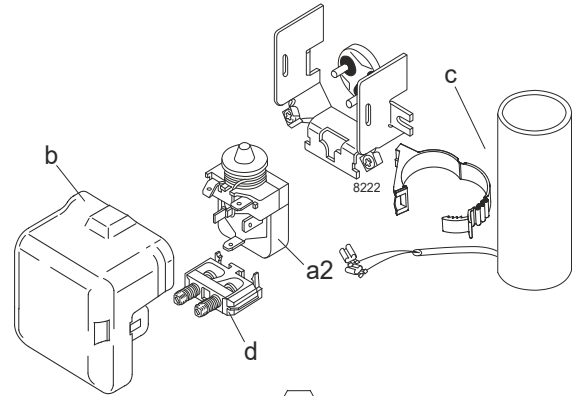

Ambient/ machine room temperatures minimum /maximum

Ambient temperature range: 10 - 43°C / 50 - 110°F

Machine room temperature range: 10 - 48°C / 50 - 119°F

Compressor cooling: fan 3m/s

Operation Limits

Operation pressure range

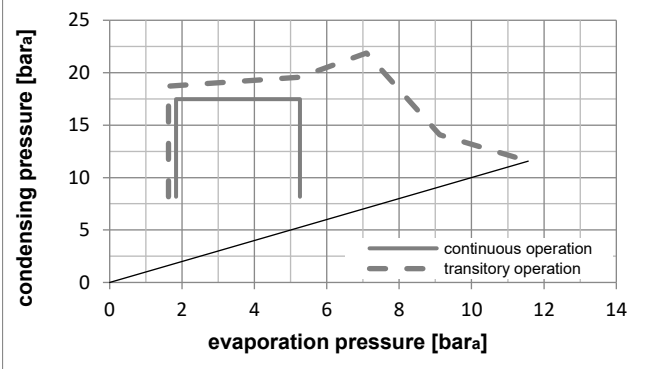
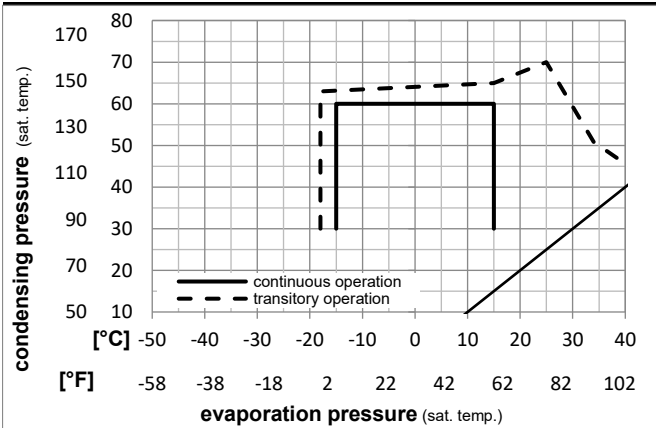

Components

a2	relay	117U6011
c	start capacitor (80μF)	117U5017
d	cord relief	103N1004
b	plastic cover	103N2008

Model

Designation	SC12GH	208-230V/60Hz	Conf. 4	Sales code:	104G8261
-------------	---------------	----------------------	---------	-------------	-----------------

Optimization + standard conditions

R513A, 230V/60Hz, CSIR, fan 3m/s, VDE, UL

		Evaporating pressure (saturation temperature)				Condensing pressure (saturation temperature)						Power consumption			
		Return gas temp.		Liquid temp.		Cooling capacity		COP	EER		P1	I	Ref. mass flow		
		pe	pc	RGT	Tliq	[W]	[Btu/h]	[kcal/h]	[W/W]	[Btu/Wh]	[kcal/Wh]	[W]	[A]	[kg/h]	
[°C]	7,2	54	35	46	1410,5	4817	1213,9	2,35	8,03	2,02	600,1	3,45	35,04	ASHRAE HBP	
[°F]	45	130	95	115											
[°C]	5	55	32	55	1132,3	3867	974,4	1,95	6,66	1,68	580,5	3,37	31,82	cecomaf HBP	
[°F]	41	131	90	131											
[°C]	5	50	20	50	1182,1	4037	1017,4	2,14	7,32	1,85	551,3	3,25	33,90	EN12900 HBP	
[°F]	41	122	68	122											
[°C]	-7	54	35	46	724,1	2473	623,2	1,61	5,50	1,39	449,8	2,85	17,74	ASHRAE MBP	
[°F]	20	130	95	115											
[°C]	-10	55	32	55	531,8	1816	457,7	1,29	4,40	1,11	412,8	2,70	14,70	cecomaf MBP	
[°F]	14	131	90	131											
[°C]	-10	45	20	45	637,4	2177	548,6	1,59	5,43	1,37	401,1	2,65	16,89	EN12900 MBP	
[°F]	14	113	68	113											

Performance tables

R513A, 230V/60Hz, CSIR, fan 3m/s, VDE, UL

	pe		Cooling capacity			COP	EER		P1	I	m
	[°C]	[°F]	[W]	[Btu/h]	[kcal/h]	[W/W]	[Btu/Wh]	[kcal/Wh]	[W]	[A]	[kg/h]
[°C / °F]	-15	5	500,7	1710	430,9	1,41	4,81	1,21	355,4	2,47	12,27
cond. pressure	-10	14	666,6	2276	573,6	1,66	5,68	1,43	401,1	2,65	16,39
pc= 45/113	-5	23	862,7	2946	742,4	1,94	6,62	1,67	444,9	2,83	21,30
return gas temp.	0	32	1092,8	3732	940,5	2,25	7,68	1,93	486,3	2,99	27,11
RGT= 32/90	5	41	1361,0	4648	1171,3	2,59	8,86	2,23	524,7	3,15	33,95
liquid temp	10	50	1670,9	5706	1438,0	2,98	10,19	2,57	559,8	3,29	41,95
Tliq= 45/113	15	59	2026,4	6921	1744,0	3,43	11,71	2,95	591,0	3,41	51,27
[°C / °F]	-15	5	390,4	1333	335,9	1,10	3,76	0,95	354,8	2,47	10,75
cond. pressure	-10	14	531,8	1816	457,7	1,29	4,40	1,11	412,8	2,70	14,70
pc= 55/131	-5	23	700,0	2391	602,5	1,49	5,09	1,28	470,1	2,93	19,44
return gas temp	0	32	898,9	3070	773,6	1,71	5,83	1,47	526,2	3,15	25,10
RGT= 32/90	5	41	1132,3	3867	974,4	1,95	6,66	1,68	580,5	3,37	31,82
liquid temp	10	50	1404,0	4795	1208,3	2,22	7,58	1,91	632,6	3,58	39,75
Tliq= 55/131	15	59	1717,8	5867	1478,4	2,52	8,60	2,17	682,0	3,78	49,06



SC Compressors

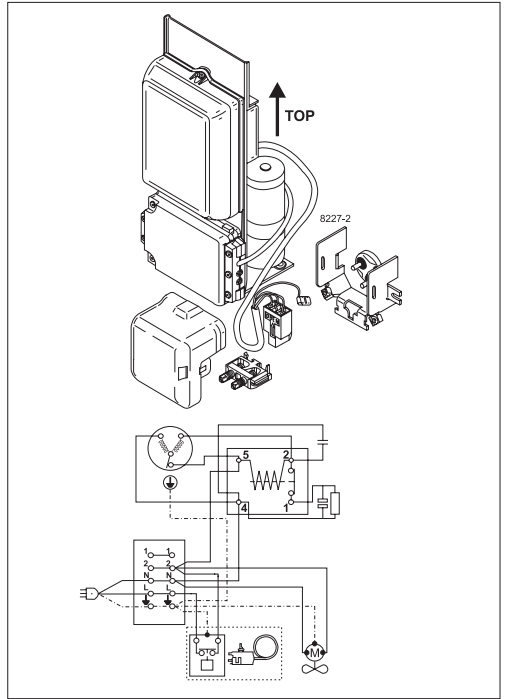



SC Compressors

Service/Repair – R290



8545



Secop accepts no responsibility for possible errors in catalogs, brochures, and other printed material. Secop reserves the right to alter its products without notice. This also applies to products already on order provided that such alterations can be made without subsequent changes being necessary to specifications already agreed. All trademarks in this material are the property of the respective companies. Secop and the Secop logotype are trademarks of Secop GmbH. All rights reserved. www.secop.com