

## Single Pack TF4CLX 115-127V 60Hz CSIR

Codice Imballo Singolo: **195B4227**

Posizione	Titolo	Codice	Quantità
1	Compressor TF4CLX	102U2114	1
2	Starting relay (overload protector MRP36AEN-6)	117U4148	1
3	Starting capacitor (280 $\mu$ F 125V, 6.3mm)	117U5025	1
4	Cord relief	117U0349	2
5	Cover	117U1021	1
6	Bolt joint for one compressor   M6   $\varnothing$ 16mm	118-1917	1

**Secop GmbH** • Lise-Meitner-Straße 29 • 24941 Flensburg, Germany • Tel: +49 46149410 • [www.secop.com](http://www.secop.com)

Secop non si assume alcuna responsabilità per eventuali errori presenti in cataloghi, brochure e altro materiale stampato. Secop si riserva il diritto di modificare i propri prodotti senza preavviso. Ciò vale anche per i prodotti già ordinati, a condizione che tali modifiche possano essere apportate senza che siano necessarie modifiche successive alle specifiche già concordate. Tutti i marchi presenti in questo materiale sono di proprietà delle rispettive aziende. Secop e il logo Secop sono marchi di Secop GmbH. Tutti i diritti sono riservati.

## Model

Designation	<b>TF4CLX</b>	115-127V/60Hz 1~	Sales code:	<b>102U2114</b>
-------------	---------------	------------------	-------------	-----------------

## Compressor design

Oil type	Polyolester	Refrigerant(s)	<b>R404A, R507</b>
Oil viscosity	32cST	Displacement	3,86cm <sup>3</sup> / 0,24cu.in
Oil quantity	283cm <sup>3</sup> / 9,6fl.oz	Compressors on pallet	125
Refr. charge - tech. limit	600g / 21,2oz		
Free gas volume comp.	1690cm <sup>3</sup> / 57,1fl.oz		
Weight	8,1kg / 17,9lbs		
Motor protection	external		
Winding resistance main	2,6Ω (at 25°C)		
Winding resistance aux	3,8Ω (at 25°C)		
Max. winding temp.	125°C / 257°F		
Max. discharge temp.	130°C / 266°F		



## General - Configurations with TF4CLX

	<b>Conf. 1</b>	<b>Conf. 2</b>
Motorconfiguration	CSIR	CSIR
Power supply (nominal)	115V/60Hz	115V/60Hz
Number of phases	1	1
Voltage range	103-135V	103-135V
Approvals	UL	UL
Starting torque	HST	HST
Note	- / -	

## Applications with TF4CLX

	<b>Conf. 1</b>	<b>Conf. 2</b>
Refrigerant	R404A	R452A
Application	LBP+MBP	LBP+MBP
System cooling	fan 1,5m/s	fan 1,5m/s
Hot gas defrost	OK	OK
Long interval pull down	OK	OK

## Electrical data - Configurations with TF4CLX

	<b>Conf. 1</b>	<b>Conf. 2</b>
Starting device type	relay	relay
Run capacitor	-/-	-/-
Start capacitor	280μF	280μF
LRA (locked rotor amps / 4s)	20A	20A
RLA (rated load amps / 1s)	3,2A	3,2A
Cut in current	20A	20A

## Model

Designation

**TF4CLX**

115-127V/60Hz 1~

Sales code:

**102U2114**

## Compressor dimensions

Housing	A Height	174mm / 6,85in
	B Height	168mm / 6,61in
	C Length shell	176,5mm / 6,95in
	D Length w. cover	226mm / 8,9in
	E Width	156mm / 6,14in

Connectors		Suction	Discharge	Process
		X	Y	Z
Diameter	[mm]	øi 6,41-6,59	øi 6,41-6,59	øi 6,41-6,59
	(i:inside, o:outside) [in]	øi 0,25-0,26	øi 0,25-0,26	øi 0,25-0,26
Material		copper	copper	copper
Horizontal angle	±2°	0°	0°	0°
Vertical angle	±2°	31,5°	28°	30°
Position l/h/w	[mm]	96/104/71	117/106/29	102/104/66
	[in]	3,8/4,1/2,8	4,6/4,2/1,1	4/4,1/2,6
Straight tube l.	[mm]	12	12	12
	[in]	0,5	0,5	0,5

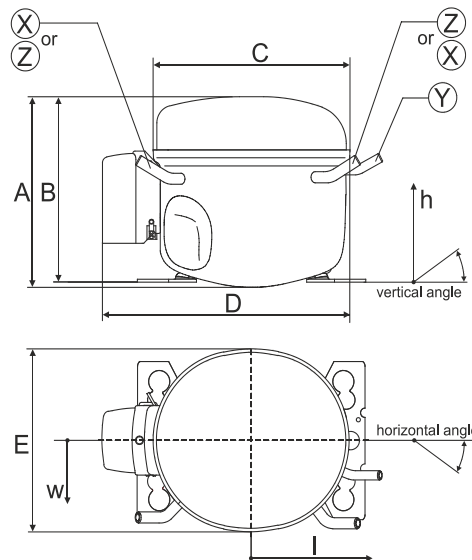

## Compressor fixation

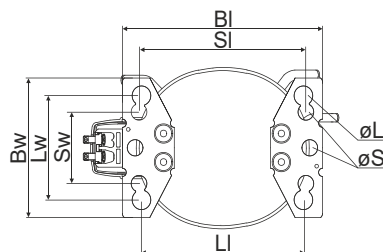

Baseplate	[mm]	[inch]
BI	204	8.03
BW	136	5.35

  

Large holes	[mm]	[inch]
LI	165	6.5
Lw	101.6	4
øL	ø 19	ø 0.75

  

Small holes	[mm]	[inch]
SI	170	6.7
Sw	70	2.76
øS	ø 16	ø 0.63

### Bolt joint

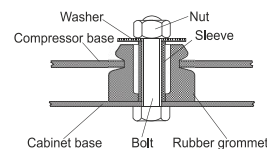

### Snap-on

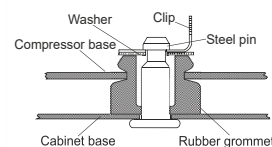

## Mounting accessories

Mounting accessories	one comp.	multi pack
Bolt joint   M6   ø16mm	118-1917	118-1918
Bolt joint   ø1/4"   ø16mm	118-1946	
Bolt joint   ø1/4"   ø19mm	118-1949	
Snap-on   ø7,3   ø16mm	118-1947	118-1919

## Application notes

LRA value on compressor label and datasheet may differ due to different test conditions for UL approval.

## Model

Designation	<b>TF4CLX</b>	<b>115V/60Hz</b>	<b>Conf. 1</b>	Sales code:	<b>102U2114</b>
-------------	---------------	------------------	----------------	-------------	-----------------

## Configuration

Motorconfiguration	CSIR
Power supply (nominal)	115V/60Hz 1~
Refrigerant	R404A
Application	LBP+MBP
Voltage range	103-135V
Starting torque	HST
Approvals	UL

## Electrical accessories / wiring diagram

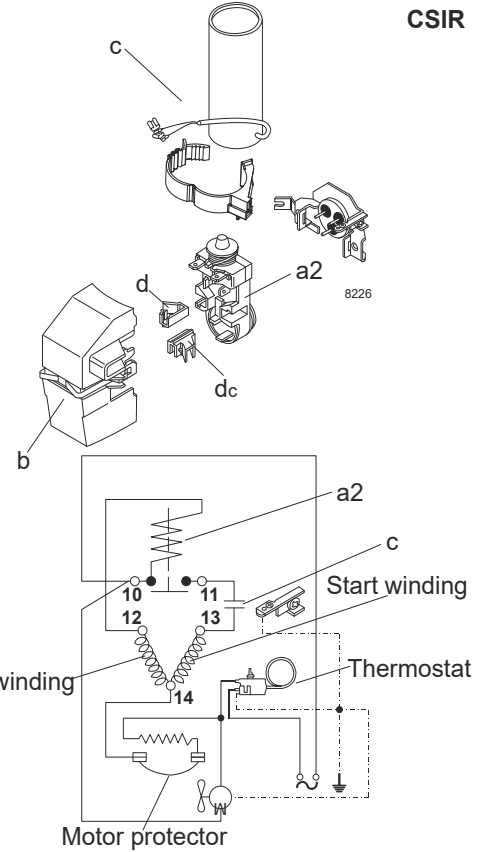

## Ambient temperatures / system cooling

Ambient temperature min.:	10°C / 50°F
Ambient temperature max.:	43°C / 110°F

System cooling (n/a: outside limits)			
T ambient	LBP	MBP	HBP
32°C / 90°F	fan 1,5m/s	fan 1,5m/s	n/a
38°C / 100°F	fan 1,5m/s	fan 1,5m/s	n/a
43°C / 110°F	fan 1,5m/s	fan 1,5m/s	n/a

## Operation pressure range

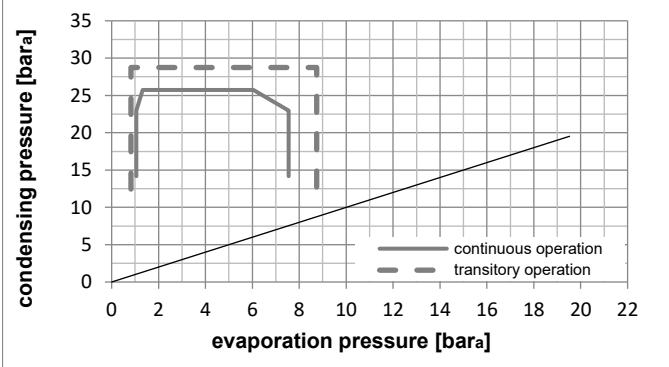
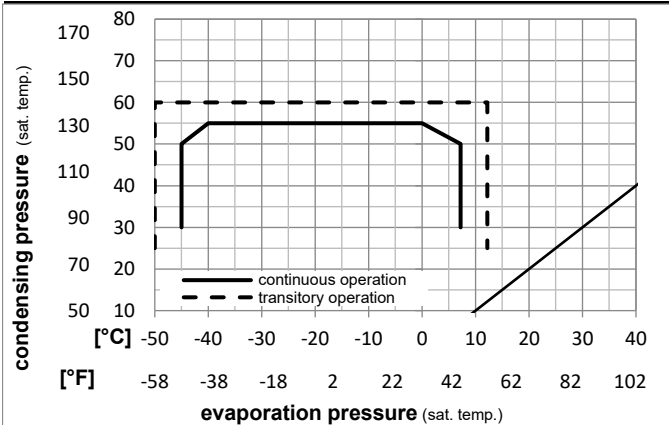

## Components

a2	assy. relay + ext. protector (MRP36EN-6)	117U4148
c	start capacitor (280µF)	117U5025
b	plastic cover	117U1021
d/dc	cord relief	117U0349
d/dc	cord relief	117U0349

## Alternative components

b	plastic cover	117U1027
---	---------------	----------

## Model

Designation	<b>TF4CLX</b>	<b>115V/60Hz</b>	<b>Conf. 1</b>	Sales code:	<b>102U2114</b>
-------------	---------------	------------------	----------------	-------------	-----------------

## Optimization + standard conditions

R404A, 115V/60Hz, CSIR, fan 3m/s, UL

	Evaporating pressure (saturation temperature)				Condensing pressure (saturation temperature)			Return gas temp.	Liquid temp.	Cooling capacity	COP	EER	Power consumption			Ref. mass flow	
	pe	pc	RGT	Tliq	[W]	[Btu/h]	[kcal/h]						P1	I	m		
[°C]	[°F]	[°C]	[°F]	[°C]	[°F]	[°C]	[°F]	[W]	[Btu/h]	[kcal/h]	[W/W]	[Btu/Wh]	[kcal/Wh]	[W]	[A]	[kg/h]	
-23	54	32	32	205,8	703	177,1	1,12	3,83	0,96	183,6	2,46	4,80	ASHRAE LBP				
-10	130	90	90														
-25	55	32	55	139,2	475	119,8	0,79	2,69	0,68	177,0	2,41	4,35	cecomaf LBP				
-13	131	90	131														
-35	40	20	40	109,3	373	94,1	0,80	2,74	0,69	136,1	2,16	2,97	EN12900 LBP				
-31	104	68	104														
-23	49	4,4	49	153,3	523	131,9	0,86	2,94	0,74	178,3	2,43	5,43	ARI540 LBP				
-10	120	40	120														
-23	41	32	32	232,9	795	200,4	1,34	4,57	1,15	173,9	2,41	5,43	AHAM LBP				
-10	105	90	90														
-35	45	32	45	100,5	343	86,5	0,74	2,53	0,64	135,8	2,14	2,69	opt				
-31	113	90	113														

## Performance tables

R404A, 115V/60Hz, CSIR, fan 3m/s, UL

	pe		Cooling capacity			COP	EER	P1	I	m	
	[°C]	[°F]	[W]	[Btu/h]	[kcal/h]	[W/W]	[Btu/Wh]	[kcal/Wh]	[W]	[A]	[kg/h]
[°C / °F]	-45	-49	46,8	160	40,3	0,45	1,52	0,38	104,9	2,04	1,24
cond. pressure	-34	-30	104,2	356	89,6	0,76	2,59	0,65	137,5	2,15	2,79
pc= 45/113	-23	-10	193,6	661	166,6	1,10	3,76	0,95	175,8	2,41	5,23
return gas temp.	-15	5	284,9	973	245,2	1,34	4,58	1,15	212,5	2,70	7,78
RGT= 32/90	-4	25	445,3	1521	383,2	1,59	5,45	1,37	279,2	3,20	12,41
liquid temp	0	32	513,1	1752	441,6	1,66	5,67	1,43	308,9	3,41	14,43
Tliq= 45/113	7,2	45	657,0	2244	565,4	1,75	5,99	1,51	374,7	3,84	18,84
[°C / °F]	-45	-49	26,3	90	22,6	0,27	0,93	0,23	96,9	2,01	0,81
cond. pressure	-34	-30	76,6	262	65,9	0,55	1,88	0,47	138,9	2,17	2,37
pc= 55/131	-23	-10	152,3	520	131,1	0,83	2,82	0,71	184,3	2,47	4,77
return gas temp	-15	5	229,1	782	197,2	1,02	3,49	0,88	224,4	2,78	7,27
RGT= 32/90	-4	25	364,5	1245	313,7	1,24	4,25	1,07	293,2	3,32	11,83
liquid temp	0	32	422,1	1442	363,3	1,31	4,46	1,12	322,9	3,55	13,84
Tliq= 55/131	7,2	45	544,8	1861	468,9	1,40	4,80	1,21	387,8	4,01	18,29

## Model

Designation	<b>TF4CLX</b>	<b>115V/60Hz</b>	<b>Conf. 2</b>	Sales code:	<b>102U2114</b>
-------------	---------------	------------------	----------------	-------------	-----------------

## Configuration

Motor configuration	CSIR
Power supply (nominal)	115V/60Hz 1~
Refrigerant	R452A
Application	LBP+MBP
Voltage range	103-135V
Starting torque	HST
Approvals	UL

## Electrical accessories / wiring diagram

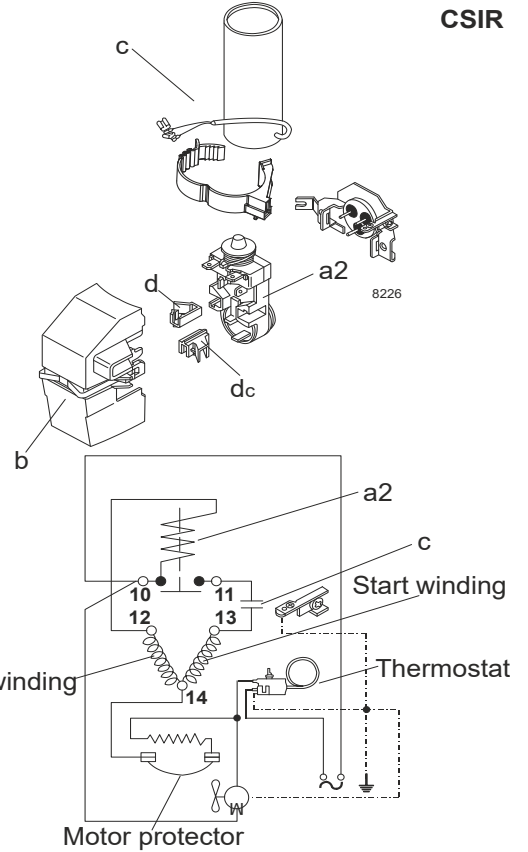

## Ambient temperatures / system cooling

Ambient temperature min.:	10°C / 50°F
Ambient temperature max.:	43°C / 110°F

System cooling (n/a: outside limits)			
T ambient	LBP	MBP	HBP
32°C / 90°F	fan 1,5m/s	fan 1,5m/s	n/a
38°C / 100°F	fan 1,5m/s	fan 1,5m/s	n/a
43°C / 110°F	fan 1,5m/s	fan 1,5m/s	n/a

## Operation pressure range

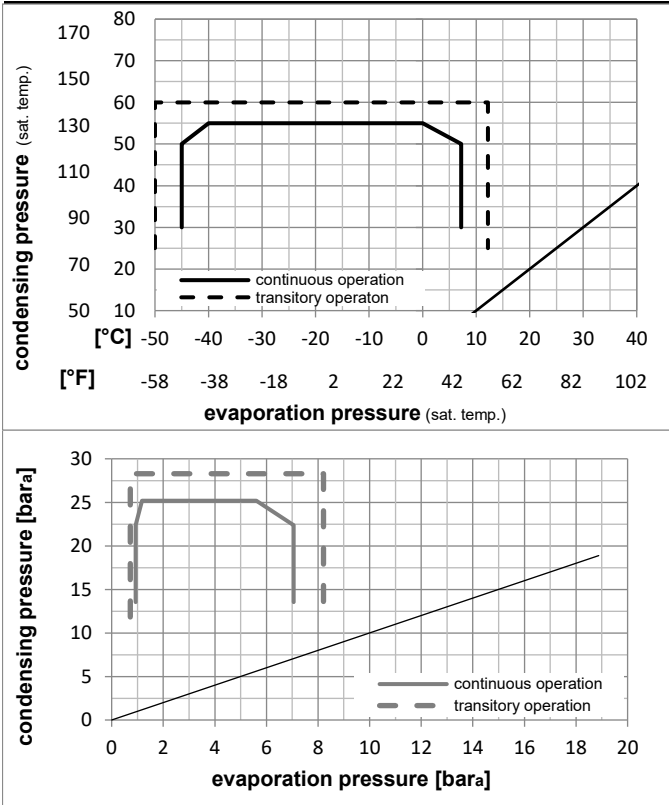

## Components

a2	assy. relay + ext. protector (MRP36EN-6)	117U4148
c	start capacitor (280µF)	117U5025
b	plastic cover	117U1021
d/dc	cord relief	117U0349
dc	cord relief	117U0349

## Alternative components

b	plastic cover	117U1027
---	---------------	----------

## Model

Designation	<b>TF4CLX</b>	<b>115V/60Hz</b>	<b>Conf. 2</b>	Sales code:	<b>102U2114</b>
-------------	---------------	------------------	----------------	-------------	-----------------

## Optimization + standard conditions

R452A, 115V/60Hz, CSIR, fan 3m/s, UL

	Evaporating pressure (saturation temperature)				Condensing pressure (saturation temperature)			Return gas temp.	Liquid temp.	Cooling capacity	COP	EER	Power consumption			Ref. mass flow	
	pe	pc	RGT	Tliq	[W]	[Btu/h]	[kcal/h]						P1	I	m		
[°C]	[°F]	[°C]	[°F]	[°C]	[°F]	[°C]	[°F]	[W]	[Btu/h]	[kcal/h]	[W/W]	[Btu/Wh]	[kcal/Wh]	[W]	[A]	[kg/h]	
-23	54	32	32	187,7	641	161,5	1,09	3,71	0,93	172,8	2,43	4,51	ASHRAE LBP				
-10	130	90	90														
-25	55	32	55	128,0	437	110,1	0,77	2,63	0,66	166,3	2,39	4,07	cecomaf LBP				
-13	131	90	131														
-35	40	20	40	98,3	336	84,6	0,77	2,63	0,66	127,8	2,12	2,75	EN12900 LBP				
-31	104	68	104														
-23	49	4,4	49	142,0	485	122,2	0,84	2,89	0,73	168,1	2,40	5,11	ARI540 LBP				
-10	120	40	120														
-23	41	32	32	213,8	730	184,0	1,30	4,45	1,12	164,2	2,37	5,14	AHAM LBP				
-10	105	90	90														
-35	45	32	45	90,2	308	77,6	0,71	2,42	0,61	127,4	2,12	2,47	opt				
-31	113	90	113														

## Performance tables

R452A, 115V/60Hz, CSIR, fan 3m/s, UL

	pe		Cooling capacity			COP	EER	P1	I	m	
	[°C]	[°F]	[W]	[Btu/h]	[kcal/h]	[W/W]	[Btu/Wh]	[kcal/Wh]	[W]	[A]	[kg/h]
[°C / °F]	-45	-49	39,8	136	34,3	0,40	1,37	0,35	99,1	1,92	1,09
cond. pressure	-34	-30	93,6	320	80,5	0,73	2,48	0,62	129,0	2,13	2,57
pc= 45/113	-23	-10	178,5	610	153,6	1,08	3,67	0,93	165,9	2,38	4,95
return gas temp.	-15	5	266,2	909	229,1	1,32	4,50	1,13	202,2	2,63	7,45
RGT= 32/90	-4	25	421,8	1440	363,0	1,57	5,36	1,35	268,7	3,09	12,01
liquid temp	0	32	488,1	1667	420,1	1,64	5,59	1,41	298,2	3,30	14,01
Tliq= 45/113	7,2	45	629,4	2149	541,6	1,73	5,91	1,49	363,5	3,75	18,39
[°C / °F]	-45	-49	21,2	72	18,2	0,23	0,80	0,20	90,8	1,86	0,66
cond. pressure	-34	-30	68,4	234	58,8	0,53	1,80	0,45	129,6	2,13	2,16
pc= 55/131	-23	-10	140,6	480	121,0	0,81	2,77	0,70	173,4	2,43	4,48
return gas temp	-15	5	214,8	734	184,9	1,01	3,44	0,87	213,2	2,71	6,92
RGT= 32/90	-4	25	347,3	1186	298,9	1,23	4,20	1,06	282,2	3,19	11,43
liquid temp	0	32	404,1	1380	347,7	1,29	4,42	1,11	312,1	3,39	13,42
Tliq= 55/131	7,2	45	525,7	1795	452,4	1,39	4,76	1,20	377,2	3,84	17,82

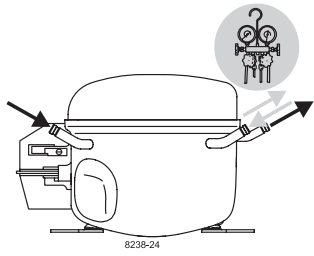

# TF Compressors

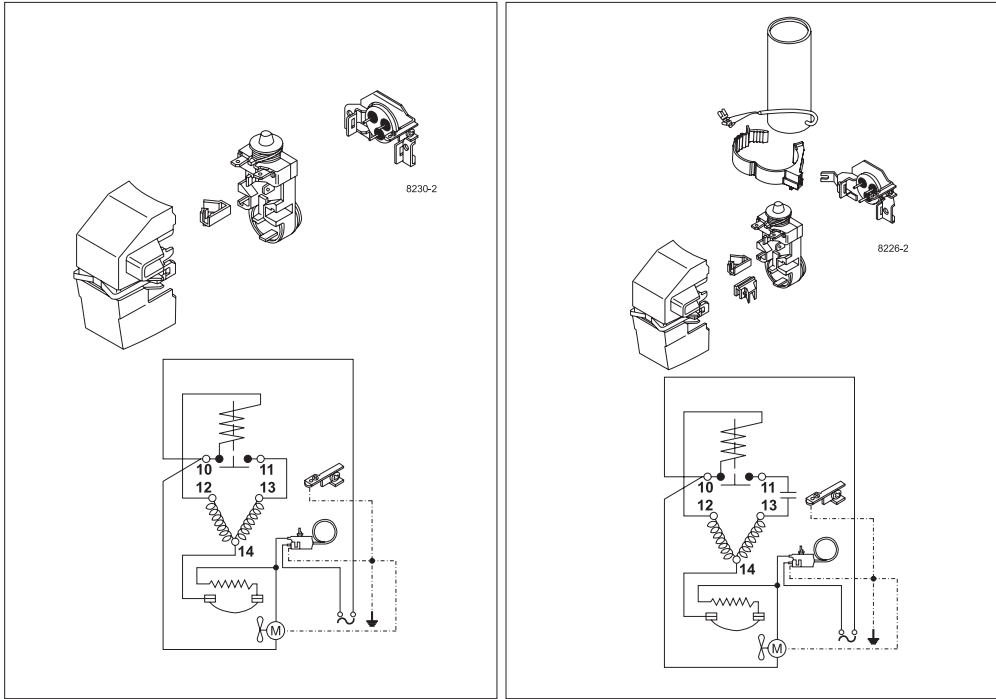



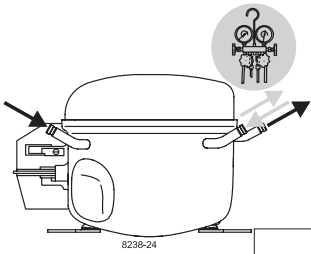

8238-24

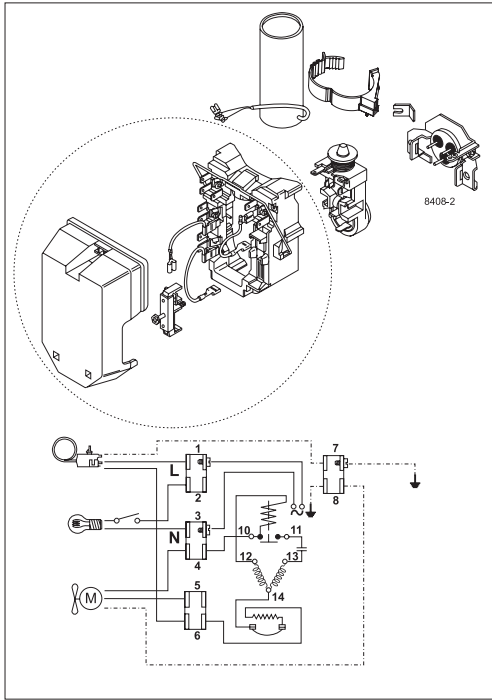
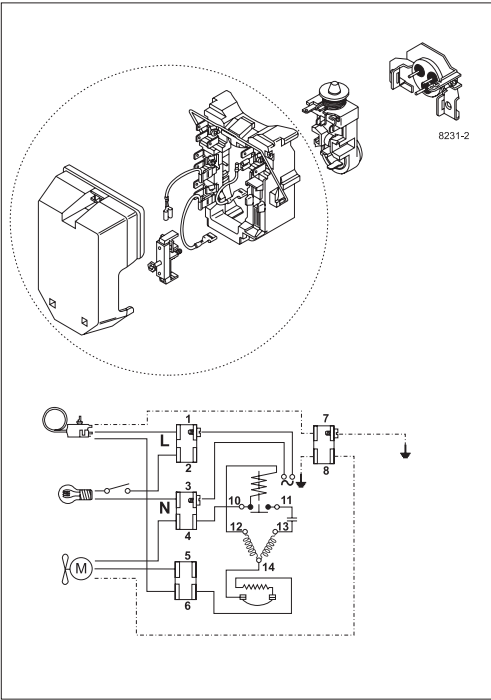

Secop accepts no responsibility for possible errors in catalogs, brochures, and other printed material. Secop reserves the right to alter its products without notice. This also applies to products already on order provided that such alterations can be made without subsequential changes being necessary to specifications already agreed. All trademarks in this material are the property of the respective companies. Secop and the Secop logotype are trademarks of Secop GmbH. All rights reserved. [www.secop.com](http://www.secop.com)