

Single Pack TFS4.5CLX 115-127V 60Hz CSIR

Codice Imballo Singolo: **195B4228**

Posizione	Titolo	Codice	Quantità
1	Compressor TFS4.5CLX	102U2115	1
2	Starting relay (overload protector MRP36AEN-6)	117U4148	1
3	Starting capacitor (280 μ F 125V, 6.3mm)	117U5025	1
4	Cord relief	117U0349	2
5	Cover	117U1021	1
6	Bolt joint for one compressor M6 \varnothing 16mm	118-1917	1

Secop GmbH • Lise-Meitner-Straße 29 • 24941 Flensburg, Germany • Tel: +49 46149410 • www.secop.com

Secop non si assume alcuna responsabilità per eventuali errori presenti in cataloghi, brochure e altro materiale stampato. Secop si riserva il diritto di modificare i propri prodotti senza preavviso. Ciò vale anche per i prodotti già ordinati, a condizione che tali modifiche possano essere apportate senza che siano necessarie modifiche successive alle specifiche già concordate. Tutti i marchi presenti in questo materiale sono di proprietà delle rispettive aziende. Secop e il logo Secop sono marchi di Secop GmbH. Tutti i diritti sono riservati.

Model

Designation	TFS4.5CLX	115-127V/60Hz 1~	Sales code:	102U2115
-------------	------------------	------------------	-------------	-----------------

Compressor design

Oil type	Polyolester	Refrigerant(s)	R404A, R507
Oil viscosity	32cST	Displacement	4,63cm ³ / 0,28cu.in
Oil quantity	283cm ³ / 9,6fl.oz	Compressors on pallet	125
Refr. charge - tech. limit	600g / 21,2oz		
Free gas volume comp.	1690cm ³ / 57,1fl.oz		
Weight	8,1kg / 17,9lbs		
Motor protection	external		
Winding resistance main	2,6Ω (at 25°C)		
Winding resistance aux	3,8Ω (at 25°C)		
Max. winding temp.	125°C / 257°F		
Max. discharge temp.	130°C / 266°F		



General - Configurations with TFS4.5CLX

	Conf. 1
Motorconfiguration	CSIR
Power supply (nominal)	115V/60Hz
Number of phases	1
Voltage range	103-135V
Approvals	UL
Starting torque	HST
Note	- / -

Applications with TFS4.5CLX

	Conf. 1
Refrigerant	R404A
Application	LBP
System cooling	fan 1,5m/s
Hot gas defrost	OK
Long interval pull down	OK

Electrical data - Configurations with TFS4.5CLX

	Conf. 1
Starting device type	relay
Run capacitor	-/-
Start capacitor	280μF
LRA (locked rotor amps / 4s)	20A
RLA (rated load amps / 1s)	3,2A
Cut in current	20A

Model

Designation

TFS4.5CLX

115-127V/60Hz 1~

Sales code:

102U2115

Compressor dimensions

Housing	A Height	174mm / 6,85in
	B Height	168mm / 6,61in
	C Length shell	176,5mm / 6,95in
	D Length w. cover	226mm / 8,9in
	E Width	156mm / 6,14in

Connectors		Suction	Discharge	Process
		X	Y	Z
Diameter	[mm]	øi 6,41-6,59	øi 6,41-6,59	øi 6,41-6,59
	(i:inside, o:outside) [in]	øi 0,25-0,26	øi 0,25-0,26	øi 0,25-0,26
Material		copper	copper	copper
Horizontal angle	±2°	0°	0°	0°
Vertical angle	±2°	31,5°	28°	30°
Position l/h/w	[mm]	96/104/71	117/106/29	102/104/66
	[in]	3,8/4,1/2,8	4,6/4,2/1,1	4/4,1/2,6
Straight tube l.	[mm]	12	12	12
	[in]	0,5	0,5	0,5

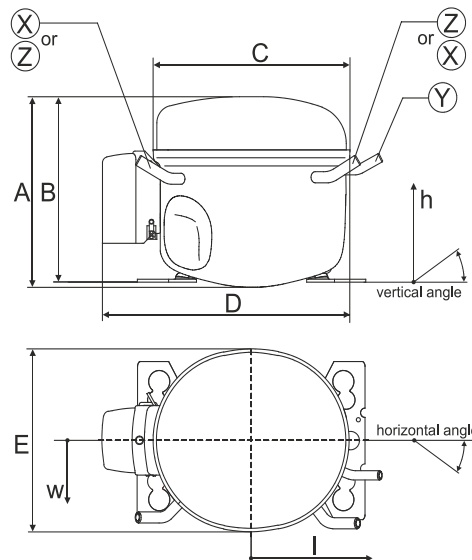

Compressor fixation

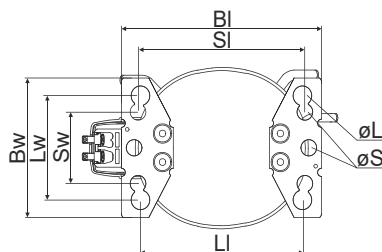

Baseplate	[mm]	[inch]
BI	204	8.03
BW	136	5.35
Large holes	[mm]	[inch]
LI	165	6.5
LW	101.6	4
ØL	ø 19	ø 0.75
Small holes	[mm]	[inch]
SI	170	6.7
SW	70	2.76
ØS	ø 16	ø 0.63

Bolt joint

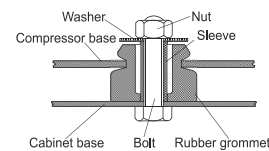

Snap-on

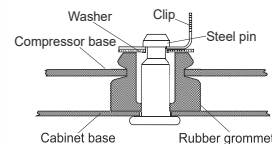

Mounting accessories

Mounting accessories	one comp.	multi pack
Bolt joint M6 ø16mm	118-1917	118-1918
Bolt joint ø1/4" ø16mm	118-1946	
Bolt joint ø1/4" ø19mm	118-1949	
Snap-on ø7,3 ø16mm	118-1947	118-1919

Application notes

LRA value on compressor label and datasheet may differ due to different test conditions for UL approval.

Model

Designation	TFS4.5CLX	115V/60Hz	Conf. 1	Sales code:	102U2115
-------------	------------------	------------------	----------------	-------------	-----------------

Configuration

Motorconfiguration	CSIR
Power supply (nominal)	115V/60Hz 1~
Refrigerant	R404A
Application	LBP
Voltage range	103-135V
Starting torque	HST
Approvals	UL

Electrical accessories / wiring diagram

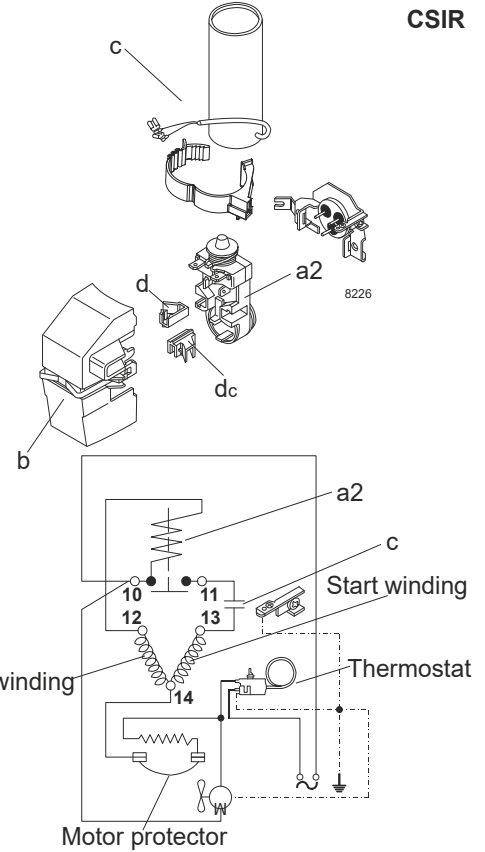

Ambient temperatures / system cooling

Ambient temperature min.:	10°C / 50°F
Ambient temperature max.:	43°C / 110°F

System cooling (n/a: outside limits)			
T ambient	LBP	MBP	HBP
32°C / 90°F	fan 1,5m/s	n/a	n/a
38°C / 100°F	fan 1,5m/s	n/a	n/a
43°C / 110°F	fan 1,5m/s	n/a	n/a

Operation pressure range

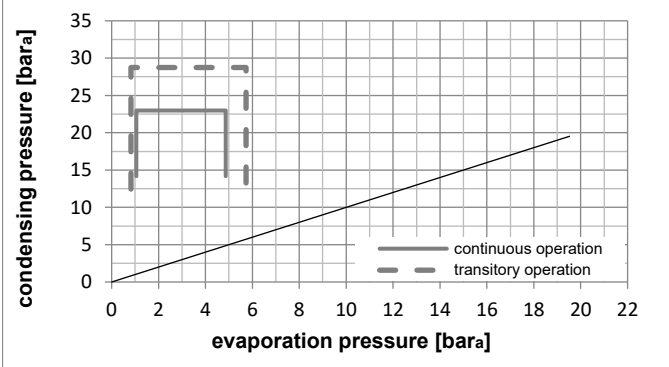
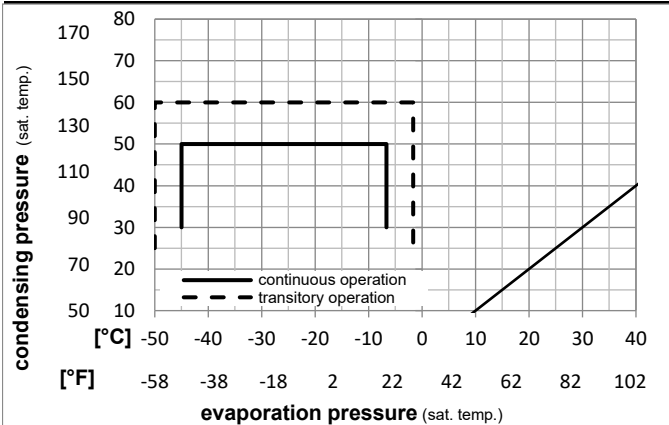

Components

a2	assy. relay + ext. protector (MRP36EN-6)	117U4148
c	start capacitor (280μF)	117U5025
b	plastic cover	117U1021
d/dc	cord relief	117U0349
d/dc	cord relief	117U0349

Alternative components

b	plastic cover	117U1027
---	---------------	----------

Model

Designation **TFS4.5CLX** **115V/60Hz** Conf. 1 Sales code: **102U2115**

Optimization + standard conditions

R404A, 115V/60Hz, CSIR, fan 3m/s, UL

	pe	pc	RGT	Tliq	Cooling capacity	COP	EER	P1	I	Ref. mass flow	
	[°C]	[°C]	[°C]	[°C]	[W]	[W/W]	[Btu/Wh]	[W]	[A]	[kg/h]	
	[°F]	[°F]	[°F]	[°F]	[Btu/h]	[W/W]	[kcal/h]	[W]	[A]	[kg/h]	
ASHRAE LBP	-23	54	32	32	271,6	1,19	233,7	228,0	2,84	6,33	
	-10	130	90	90							
cecomaf LBP	-25	55	32	55	184,9	0,85	159,1	218,3	2,77	5,78	
	-13	131	90	131							
EN12900 LBP	-35	40	20	40	147,3	0,94	126,8	157,5	2,40	4,00	
	-31	104	68	104							
ARI540 LBP	-23	49	4,4	49	200,7	0,91	172,7	220,2	2,79	7,10	
	-10	120	40	120							
AHAM LBP	-23	41	32	32	302,2	1,41	260,1	213,7	2,76	7,04	
	-10	105	90	90							
opt	-35	45	32	45	137,0	0,87	117,9	157,1	2,38	3,66	
	-31	113	90	113							

Performance tables

R404A, 115V/60Hz, CSIR, fan 3m/s, UL

	pe	Cooling capacity			COP	EER	P1	I	m
	[°C]	[°F]	[W]	[Btu/h]	[W/W]	[Btu/Wh]	[W]	[A]	[kg/h]
[°C / °F]	-45	-49	70,4	240	0,63	2,16	111,3	2,22	1,87
cond. pressure	-34	-30	141,5	483	0,89	3,03	159,7	2,39	3,78
pc= 45/113	-29	-20	191,7	655	1,03	3,51	186,5	2,55	5,15
return gas temp.	-23	-10	252,3	862	1,17	3,98	216,5	2,77	6,82
RGT= 32/90	-21	-5	287,0	980	1,23	4,20	233,2	2,90	7,78
liquid temp	-15	5	365,5	1248	1,35	4,61	271,0	3,19	9,98
Tliq= 45/113	-7	20	508,3	1736	1,49	5,08	341,5	3,72	14,08
[°C / °F]	-45	-49	45,0	154	0,45	1,55	99,4	2,18	1,38
cond. pressure	-34	-30	107,4	367	0,66	2,27	161,7	2,41	3,32
pc= 55/131	-29	-20	150,1	513	0,77	2,64	194,3	2,60	4,67
return gas temp	-23	-10	201,2	687	0,88	3,00	229,0	2,85	6,30
RGT= 32/90	-21	-5	230,3	787	0,93	3,18	247,7	2,99	7,24
liquid temp	-15	5	296,4	1012	1,03	3,51	288,6	3,31	9,40
Tliq= 55/131	-7	20	416,8	1424	1,15	3,93	361,8	3,89	13,44

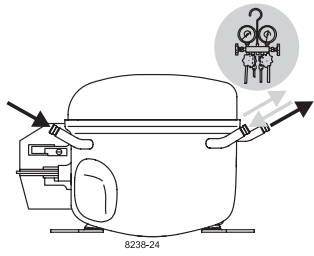

TF Compressors

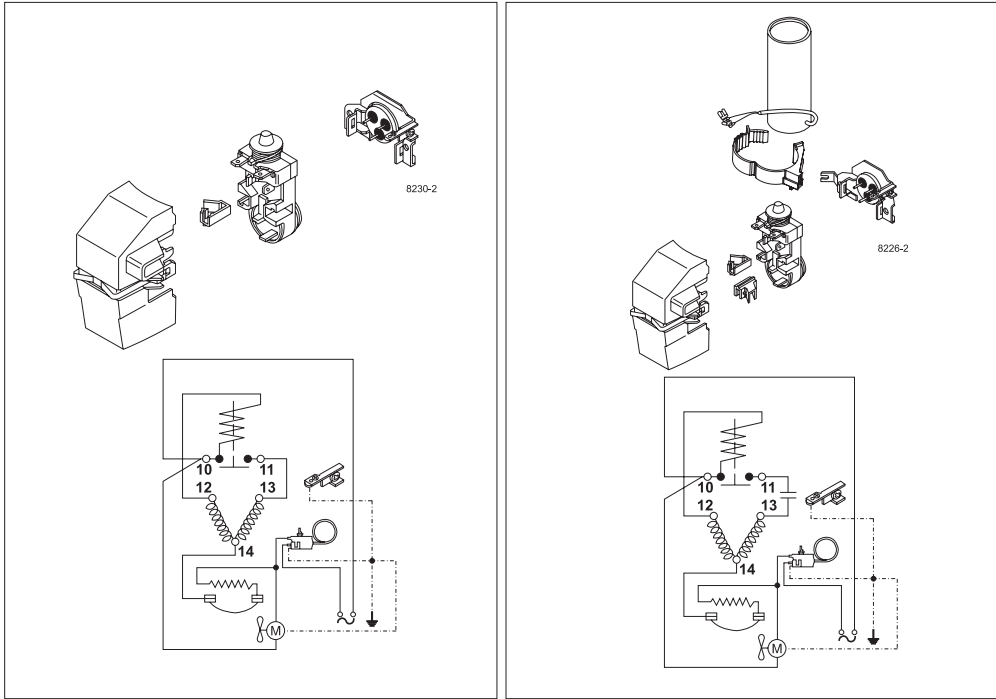

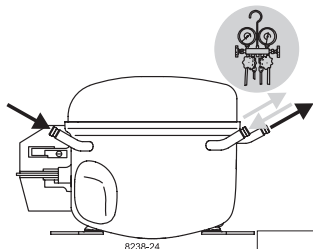

8238-24

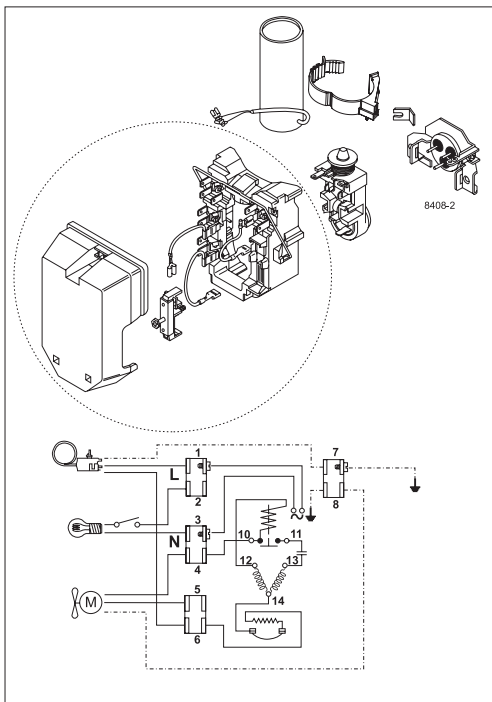
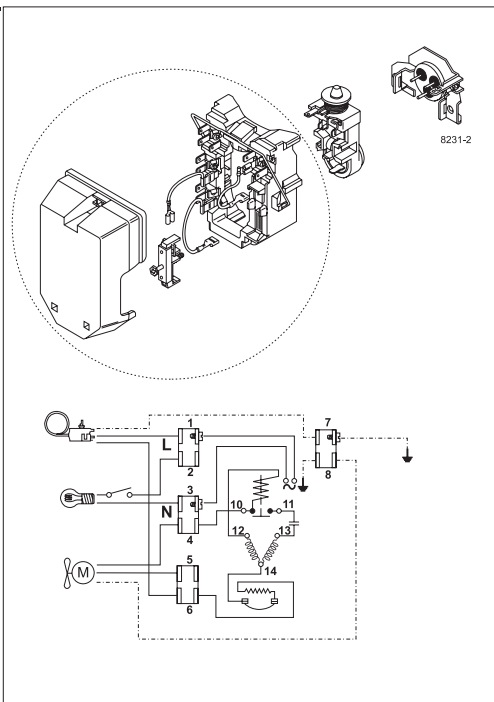

Secop accepts no responsibility for possible errors in catalogs, brochures, and other printed material. Secop reserves the right to alter its products without notice. This also applies to products already on order provided that such alterations can be made without subsequential changes being necessary to specifications already agreed. All trademarks in this material are the property of the respective companies. Secop and the Secop logotype are trademarks of Secop GmbH. All rights reserved. www.secop.com