

## Single Pack SC18MFX 220-240V 50Hz / 208-230V 60Hz CSIR

Codice Imballo Singolo: **195B4240**

Posizione	Titolo	Codice	Quantità
1	Compressor SC18MFX	104G8804	1
2	Starting relay	117U6019	1
3	Starting capacitor (80 $\mu$ F 220V, 6.3mm)	117U5017	1
4	Cord relief	103N1004	1
5	Cover	103N2008	1
6	Bolt joint for one compressor   M6   $\varnothing$ 16mm	118-1917	1

Secop GmbH • Lise-Meitner-Straße 29 • 24941 Flensburg, Germany • Tel: +49 46149410 • [www.secop.com](http://www.secop.com)

Secop non si assume alcuna responsabilità per eventuali errori presenti in cataloghi, brochure e altro materiale stampato. Secop si riserva il diritto di modificare i propri prodotti senza preavviso. Ciò vale anche per i prodotti già ordinati, a condizione che tali modifiche possano essere apportate senza che siano necessarie modifiche successive alle specifiche già concordate. Tutti i marchi presenti in questo materiale sono di proprietà delle rispettive aziende. Secop e il logo Secop sono marchi di Secop GmbH. Tutti i diritti sono riservati.

## Model

Designation	<b>SC18MFX</b>	<b>220-240V/50Hz 1~ 208-230V/60Hz 1~</b>	Sales code:	<b>104G8804</b>
-------------	----------------	--	-------------	-----------------

## Compressor design

Oil type	Polyolester	Refrigerant(s)	<b>R134a, R513A</b>
Oil viscosity	22cST	Displacement	17,69cm <sup>3</sup> / 1,08cu.in
Oil quantity	550cm <sup>3</sup> / 18,6fl.oz	Compressors on pallet	80
Refr. charge - tech. limit	1300g / 45,9oz		
Free gas volume comp.	1460cm <sup>3</sup> / 49,4fl.oz		
Weight	13,8kg / 30,4lbs		
Motor protection	1# internal		
Winding resistance main	3,7Ω (at 25°C)		
Winding resistance aux	14Ω (at 25°C)		
Max. winding temp.	125°C / 257°F		
Max. discharge temp.	130°C / 266°F		



## General - Configurations with SC18MFX

	<b>Conf. 1</b>	<b>Conf. 2</b>	<b>Conf. 3</b>	<b>Conf. 4</b>	<b>Conf. 5</b>
Motorconfiguration	CSIR	CSCR	CSCR	CSIR	CSCR
Power supply (nominal)	220-240V/50Hz	220-240V/50Hz	208-230V/60Hz	220-240V/50Hz	208-230V/60Hz
Number of phases	1	1	1	1	1
Voltage range	187-254V	187-254V	187-254V	187-254V	187-254V
Approvals	CCC, EAC, VDE	CCC, EAC, VDE	CCC, EAC, VDE	CCC, EAC, VDE	CCC, EAC, VDE
Starting torque	HST	HST	HST	HST	HST
Note	- / -				

## Applications with SC18MFX

	<b>Conf. 1</b>	<b>Conf. 2</b>	<b>Conf. 3</b>	<b>Conf. 4</b>	<b>Conf. 5</b>
Refrigerant	R134a	R134a	R134a	R513A	R513A
Application	MBP	MBP	MBP	MBP	MBP
System cooling	fan 3m/s	fan 3m/s	fan 3m/s	fan 3m/s	fan 3m/s
Hot gas defrost	OK	OK	OK	OK	OK
Long interval pull down	OK	OK	OK	OK	OK

## Electrical data - Configurations with SC18MFX

	<b>Conf. 1</b>	<b>Conf. 2</b>	<b>Conf. 3</b>	<b>Conf. 4</b>	<b>Conf. 5</b>
Starting device type	relay	relay	relay	relay	relay
Run capacitor	-/-	10μF	10μF	-/-	10μF
Start capacitor	80μF	80μF	80μF	80μF	80μF
LRA (locked rotor amps / 4s)	20,43A	20,43A	19A	20,43A	19A
RLA (rated load amps / 1s)	3,9A	4,2A	3,5A	3,9A	3,5A
Cut in current	20,43A	20,43A	19A	20,43A	19A

## Model

Designation **SC18MFX** 220-240V/50Hz 1~ 208-230V/60Hz 1~ Sales code: **104G8804**

## Compressor dimensions

<b>Housing</b>	A Height	219mm / 8,62in
	B Height	213mm / 8,39in
	C Length shell	218mm / 8,58in
	D Length w. cover	255mm / 10,04in
	E Width	151mm / 5,94in

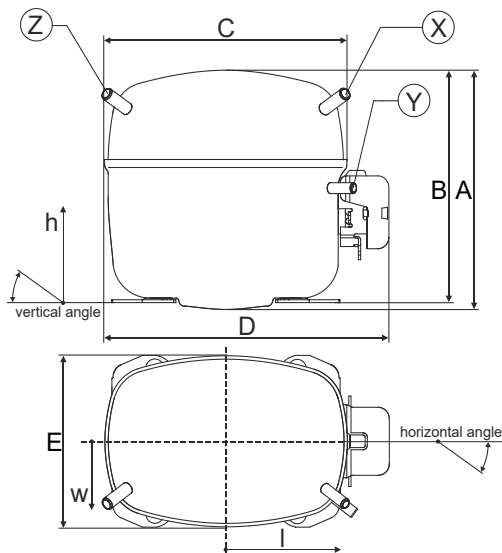

Connectors	Suction		Discharge		Process	
	X		Y		Z	
Diameter [mm]	øi 10,11-10,29		øi 6,11-6,29		øi 6,11-6,29	
(i:inside, o:outside) [in]	øi 0,4-0,41		øi 0,24-0,25		øi 0,24-0,25	
Material	copper		copper		copper	
Horizontal angle ±2°	37°		37°		143°	
Vertical angle ±2°	30°		0°		150°	
Position l/h/w [mm]	107/193/55		115/110/63		-107/193/55	
[in]	4,2/7,6/2,2		4,5/4,3/2,5		-4,2/7,6/2,2	
Straight tube l.	[mm]		12		12	
	[in]		0,5		0,5	

## Compressor fixation

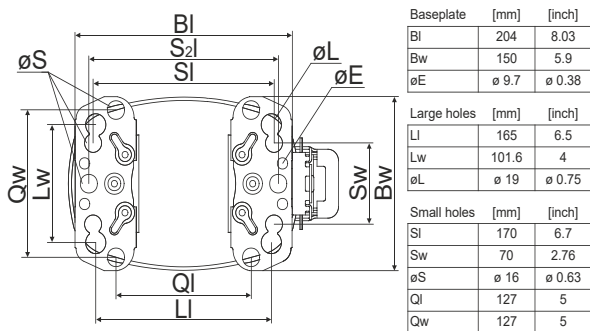

### Bolt joint

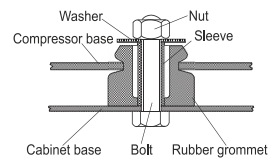

### Snap-on

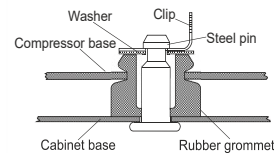

Mounting accessories	one comp.	multi pack
Bolt joint   M6   ø16mm	118-1917	118-1918
Bolt joint   ø1/4"   ø16mm	118-1946	
Bolt joint   ø1/4"   ø19mm	118-1949	
Snap-on   ø7,3   ø16mm	118-1947	118-1919

## Application notes

Provision for PE Grounding is located at the PE Stamp on the compressor

### Model

Designation	<b>SC18MFX</b>	<b>220-240V/50Hz</b>	Conf. 1	Sales code:	<b>104G8804</b>
-------------	----------------	----------------------	---------	-------------	-----------------

### Configuration

Motorconfiguration	CSIR
Power supply (nominal)	220-240V/50Hz 1~
Refrigerant	R134a
Application	MBP
Voltage range	187-254V
Starting torque	HST
Approvals	CCC
	EAC
	VDE

### Electrical accessories / wiring diagram

CSIR

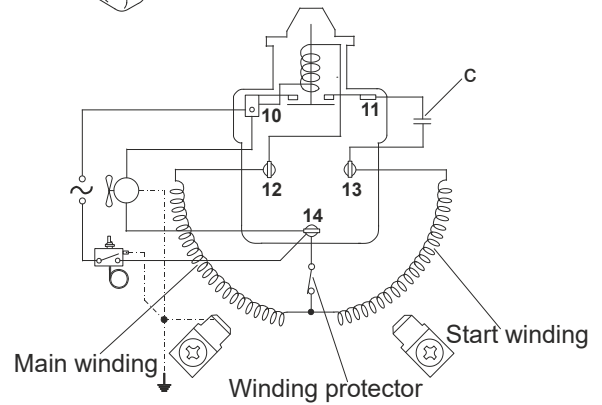
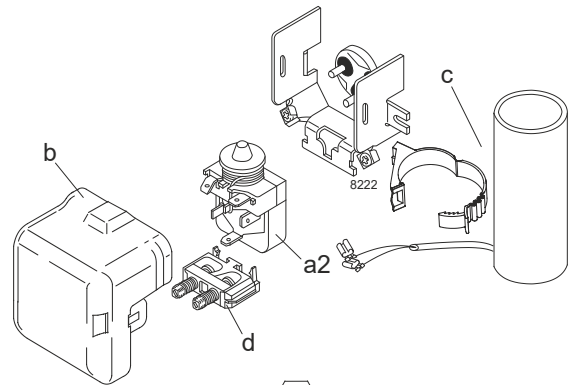

### Ambient/ machine room temperatures minimum /maximum

Ambient temperature range:	10 - 43°C / 50 - 110°F
Machine room temperature range:	10 - 48°C / 50 - 119°F
Compressor cooling:	fan 3m/s

### Operation Limits

### Operation pressure range

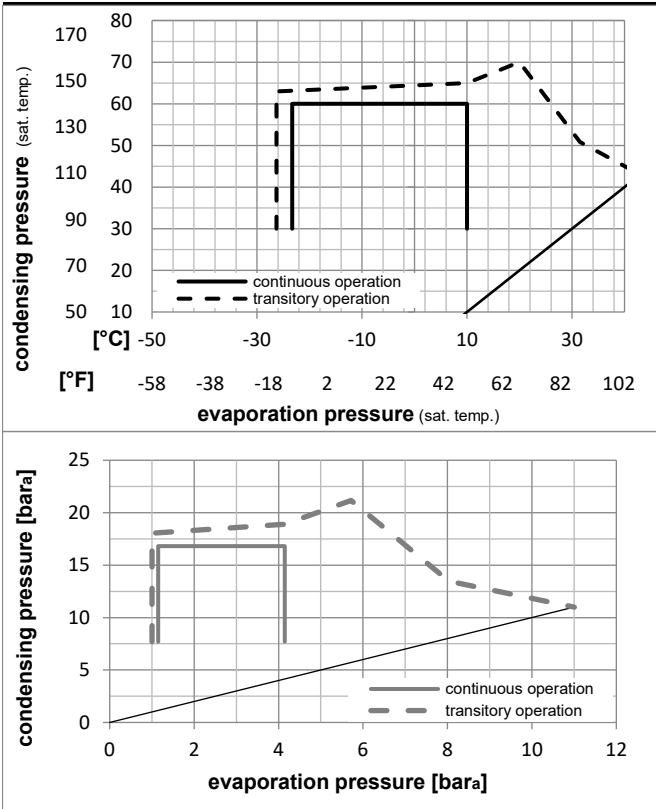

### Components

a2	relay	117U6019
c	start capacitor (80µF)	117U5017
d	cord relief	103N1004
b	plastic cover	103N2008

### Alternative components

a2	relay	117U6019
c	start capacitor i-pack 40# (80µF)	117U5067
d	cord relief	103N1004
b	plastic cover	103N2008

## Model

Designation	<b>SC18MFX</b>	<b>220-240V/50Hz</b>	Conf. 1	Sales code:	<b>104G8804</b>
-------------	----------------	----------------------	---------	-------------	-----------------

## Optimization + standard conditions

R134a, 220V/50Hz, CSIR, fan 3m/s, CCC, EAC, VDE

Evaporating pressure (saturation temperature)					Condensing pressure (saturation temperature)					Power consumption					ASHRAE MBP
Return gas temp.				Cooling capacity	COP	EER	P1	Current consumption		Ref. mass flow	cecomaf MBP				
pe	pc	RGT	Tliq					[W]	[Btu/h]			[kcal/h]	[W/W]	[Btu/Wh]	
[°C]	-7	54	35	46	917,1	3132	789,3	1,63	5,56	1,40		563,3	3,56	20,01	ASHRAE MBP
[°F]	20	130	95	115											
[°C]	-10	55	32	55	708,6	2420	609,8	1,34	4,59	1,16	527,1	3,43	17,13	cecomaf MBP	
[°F]	14	131	90	131											
[°C]	-10	45	20	45	793,2	2709	682,6	1,59	5,43	1,37	498,5	3,31	18,57	EN12900 MBP	
[°F]	14	113	68	113											
[°C]	-7	49	18	49	867,6	2963	746,7	1,60	5,46	1,38	542,7	3,48	21,43	ARI540 MBP	
[°F]	20	120	65	120											
[°C]	-10	45	32	45	822,9	2810	708,2	1,65	5,64	1,42	498,5	3,31	18,01	opt	
[°F]	14	113	90	113											
[°C]	-25	45	32	45	376,3	1285	323,9	1,04	3,55	0,89	362,3	2,84	8,15	opt	
[°F]	-13	113	90	113											

## Performance tables

R134a, 220V/50Hz, CSIR, fan 3m/s, CCC, EAC, VDE

	pe		Cooling capacity			COP	EER		P1	I	m
	[°C]	[°F]	[W]	[Btu/h]	[kcal/h]	[W/W]	[Btu/Wh]	[kcal/Wh]	[W]	[A]	[kg/h]
[°C / °F]	-23	-10	415,2	1418	357,3	1,10	3,75	0,95	377,7	2,89	9,00
cond. pressure	-20	-4	498,3	1702	428,9	1,22	4,18	1,05	407,6	2,99	10,83
pc= 45/113	-15	5	645,8	2206	555,8	1,43	4,87	1,23	452,8	3,15	14,08
return gas temp.	-10	14	822,9	2810	708,2	1,65	5,64	1,42	498,5	3,31	18,01
RGT= 32/90	0	32	1282,4	4380	1103,6	2,16	7,39	1,86	592,8	3,67	28,36
liquid temp	5	41	1572,9	5372	1353,7	2,45	8,36	2,11	642,3	3,86	35,02
Tliq= 45/113	10	50	1909,5	6521	1643,4	2,75	9,40	2,37	694,0	4,06	42,85
[°C / °F]	-23	-10	350,7	1198	301,8	0,93	3,18	0,80	376,7	2,91	8,39
cond. pressure	-20	-4	424,0	1448	364,9	1,02	3,50	0,88	413,8	3,04	10,17
pc= 55/131	-15	5	553,4	1890	476,2	1,18	4,02	1,01	470,2	3,23	13,32
return gas temp	-10	14	708,6	2420	609,8	1,34	4,59	1,16	527,1	3,43	17,13
RGT= 32/90	0	32	1112,8	3801	957,7	1,73	5,90	1,49	644,0	3,86	27,22
liquid temp	5	41	1370,1	4679	1179,1	1,94	6,64	1,67	705,0	4,09	33,76
Tliq= 55/131	10	50	1669,6	5702	1436,9	2,17	7,42	1,87	768,3	4,32	41,50

## Model

Designation	<b>SC18MFX</b>	<b>220-240V/50Hz</b>	<b>Conf. 2</b>	Sales code:	<b>104G8804</b>
-------------	----------------	----------------------	----------------	-------------	-----------------

## Configuration

Motorconfiguration	CSCR
Power supply (nominal)	220-240V/50Hz 1~
Refrigerant	R134a
Application	MBP
Voltage range	187-254V
Starting torque	HST
Approvals	CCC
	EAC
	VDE

## Electrical accessories / wiring diagram

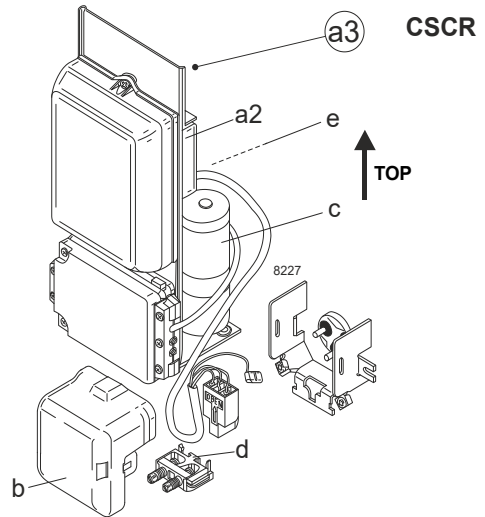

## Ambient/ machine room temperatures minimum /maximum

Ambient temperature range: 10 - 43°C / 50 - 110°F

Machine room temperature range: 10 - 48°C / 50 - 119°F

Compressor cooling: fan 3m/s

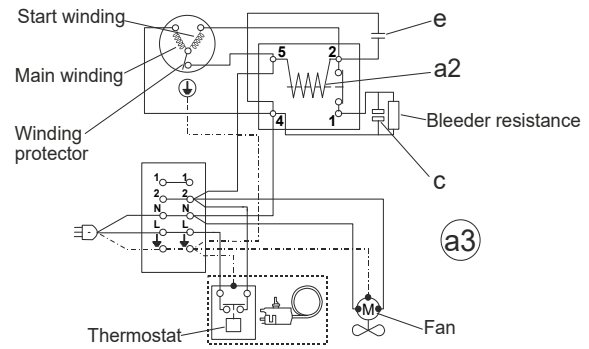

## Operation Limits

### Operation pressure range

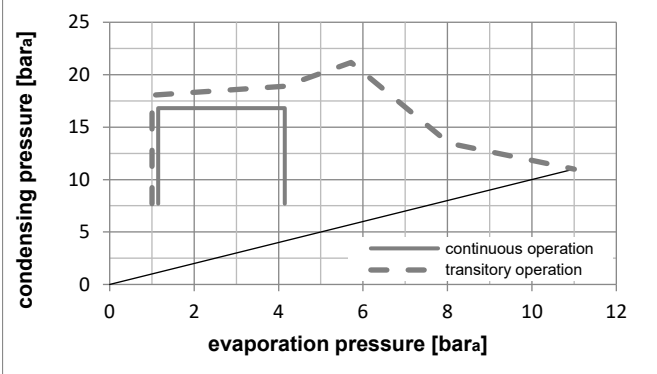
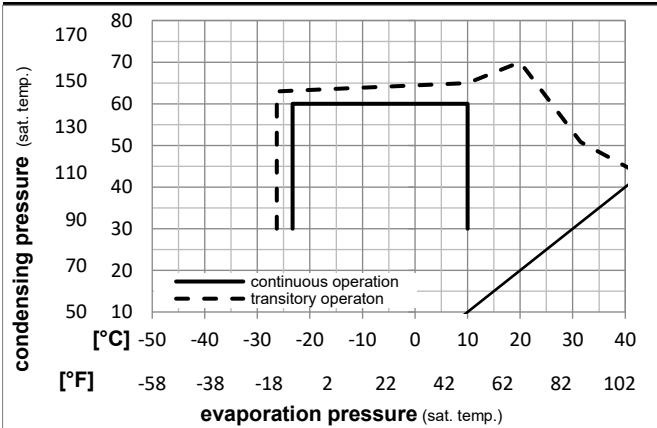

### Components

a3	SC starter kit (550mm)	117-7027
b	plastic cover	103N2008
d	cord relief	103N1004

### Alternative components

a3	SC starter kit (1000mm)	117-7040
b	plastic cover	103N2008
d	cord relief	103N1004

## Model

Designation	<b>SC18MFX</b>	<b>220-240V/50Hz</b>	<b>Conf. 2</b>	Sales code:	<b>104G8804</b>
-------------	----------------	----------------------	----------------	-------------	-----------------

## Optimization + standard conditions

R134a, 220V/50Hz, CSCR, fan 3m/s, CCC, EAC, VDE

		Evaporating pressure (saturation temperature)				Condensing pressure (saturation temperature)						Power consumption			
		Return gas temp.		Liquid temp.		Cooling capacity		COP	EER		P1	I	Ref. mass flow		
		pe	pc	RGT	Tliq	[W]	[Btu/h]	[kcal/h]	[W/W]	[Btu/Wh]	[kcal/Wh]	[W]	[A]	[kg/h]	
[°C]	-7	54	35	46	935,9	3196	805,5	1,74	5,93	1,49	539,3	2,81	20,42	<b>ASHRAE MBP</b>	
[°F]	20	130	95	115											
[°C]	-10	55	32	55	722,2	2467	621,5	1,42	4,86	1,23	507,3	2,67	17,46	<b>cecomaf MBP</b>	
[°F]	14	131	90	131											
[°C]	-10	45	20	45	811,0	2770	698,0	1,69	5,77	1,45	480,1	2,56	18,98	<b>EN12900 MBP</b>	
[°F]	14	113	68	113											
[°C]	-7	49	18	49	887,1	3029	763,4	1,70	5,82	1,47	520,7	2,73	21,91	<b>ARI540 MBP</b>	
[°F]	20	120	65	120											
[°C]	-10	45	32	45	841,4	2874	724,1	1,75	5,99	1,51	480,1	2,56	18,41	<b>opt</b>	
[°F]	14	113	90	113											
[°C]	-25	45	32	45	384,1	1312	330,5	1,10	3,76	0,95	349,1	2,08	8,32	<b>opt</b>	
[°F]	-13	113	90	113											

## Performance tables

R134a, 220V/50Hz, CSCR, fan 3m/s, CCC, EAC, VDE

	pe		Cooling capacity			COP	EER		P1	I	m
	[°C]	[°F]	[W]	[Btu/h]	[kcal/h]	[W/W]	[Btu/Wh]	[kcal/Wh]	[W]	[A]	[kg/h]
[°C / °F]	-23	-10	424,0	1448	364,9	1,16	3,97	1,00	365,1	2,13	9,19
cond. pressure	-20	-4	509,2	1739	438,2	1,29	4,40	1,11	395,1	2,23	11,06
pc= 45/113	-15	5	660,3	2255	568,3	1,51	5,14	1,30	438,5	2,39	14,39
return gas temp.	-10	14	841,4	2874	724,1	1,75	5,99	1,51	480,1	2,56	18,41
RGT= 32/90	0	32	1310,2	4475	1127,6	2,33	7,97	2,01	561,5	2,92	28,97
liquid temp	5	41	1606,1	5485	1382,2	2,66	9,10	2,29	602,9	3,11	35,76
Tliq= 45/113	10	50	1948,4	6654	1676,8	3,02	10,30	2,60	645,8	3,31	43,72
[°C / °F]	-23	-10	355,4	1214	305,9	0,98	3,35	0,84	362,4	2,13	8,51
cond. pressure	-20	-4	430,4	1470	370,4	1,08	3,67	0,93	400,3	2,26	10,32
pc= 55/131	-15	5	563,1	1923	484,6	1,24	4,23	1,06	455,0	2,46	13,55
return gas temp	-10	14	722,2	2467	621,5	1,42	4,86	1,23	507,3	2,67	17,46
RGT= 32/90	0	32	1136,5	3881	978,1	1,87	6,39	1,61	607,4	3,11	27,80
liquid temp	5	41	1399,9	4781	1204,7	2,13	7,28	1,83	657,1	3,34	34,50
Tliq= 55/131	10	50	1706,2	5827	1468,4	2,41	8,24	2,08	707,5	3,58	42,41

## Model

Designation	<b>SC18MFX</b>	<b>208-230V/60Hz</b>	<b>Conf. 3</b>	Sales code:	<b>104G8804</b>
-------------	----------------	----------------------	----------------	-------------	-----------------

## Configuration

Motorconfiguration	CSCR
Power supply (nominal)	208-230V/60Hz 1~
Refrigerant	R134a
Application	MBP
Voltage range	187-254V
Starting torque	HST
Approvals	CCC
	EAC
	VDE

## Electrical accessories / wiring diagram

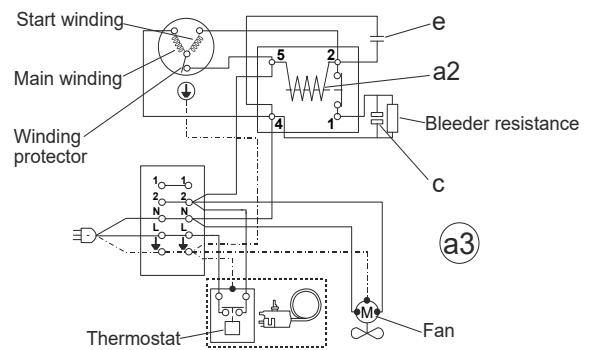
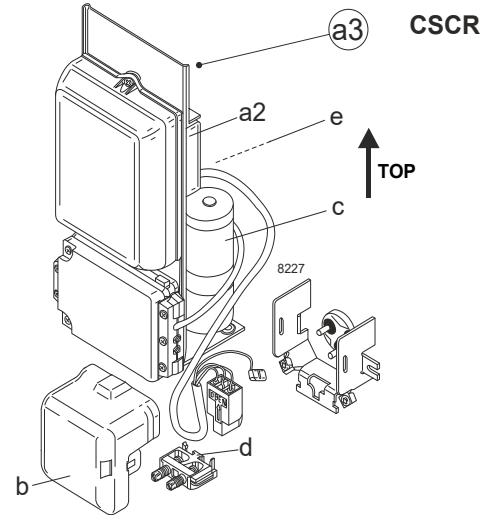

## Ambient/ machine room temperatures minimum /maximum

Ambient temperature range: 10 - 43°C / 50 - 110°F

Machine room temperature range: 10 - 48°C / 50 - 119°F

Compressor cooling: fan 3m/s

## Operation Limits

### Operation pressure range

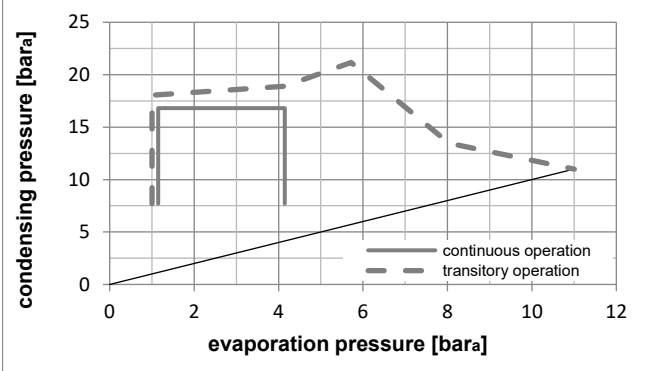
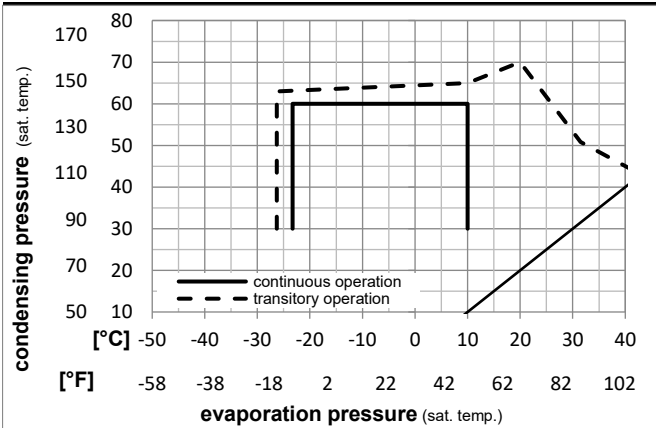

### Components

a3	SC starter kit (550mm)	117-7027
b	plastic cover	103N2008
d	cord relief	103N1004

### Alternative components

a3	SC starter kit (1000mm)	117-7040
b	plastic cover	103N2008
d	cord relief	103N1004



## Model

Designation **SC18MFX** **208-230V/60Hz** Conf. 3 Sales code: **104G8804**

## Optimization + standard conditions

R134a, 220V/60Hz, CSCR, fan 3m/s, CCC, EAC, VDE

		Evaporating pressure (saturation temperature)				Cooling capacity			COP	EER	P1	I	Ref. mass flow		
		pe	pc	RGT	Tliq	[W]	[Btu/h]	[kcal/h]	[W/W]	[Btu/Wh]	[kcal/Wh]	[W]	[A]	[kg/h]	
[°C]	[°F]														
-7	20	54	130	35	95	1096,6	3745	943,8	1,75	5,96	1,50	628,2	2,82	23,93	ASHRAE MBP
-10	14	55	131	32	90	850,5	2905	732,0	1,45	4,97	1,25	585,0	2,63	20,57	cecomaf MBP
-10	14	45	113	20	68	947,7	3237	815,6	1,71	5,83	1,47	555,3	2,48	22,18	EN12900 MBP
-7	20	49	120	18	65	1035,2	3536	890,9	1,70	5,81	1,46	608,7	2,73	25,57	ARI540 MBP
-10	14	45	113	32	90	983,3	3358	846,2	1,77	6,05	1,52	555,3	2,48	21,52	opt
-25	-13	45	113	32	90	456,4	1559	392,8	1,16	3,97	1,00	392,3	1,75	9,89	opt

## Performance tables

R134a, 220V/60Hz, CSCR, fan 3m/s, CCC, EAC, VDE

	pe		Cooling capacity			COP	EER		P1	I	m
	[°C]	[°F]	[W]	[Btu/h]	[kcal/h]	[W/W]	[Btu/Wh]	[kcal/Wh]	[W]	[A]	[kg/h]
[°C / °F]	-23	-10	502,8	1717	432,7	1,23	4,19	1,06	409,6	1,83	10,90
cond. pressure	-20	-4	601,5	2054	517,7	1,35	4,63	1,17	444,1	1,98	13,07
pc= 45/113	-15	5	775,5	2649	667,4	1,56	5,31	1,34	498,5	2,23	16,91
return gas temp.	-10	14	983,3	3358	846,2	1,77	6,05	1,52	555,3	2,48	21,52
RGT= 32/90	0	32	1519,2	5188	1307,4	2,25	7,69	1,94	675,0	3,04	33,60
liquid temp	5	41	1857,0	6342	1598,2	2,52	8,60	2,17	737,3	3,34	41,34
Tliq= 45/113	10	50	2248,0	7677	1934,6	2,81	9,59	2,42	800,9	3,65	50,44
[°C / °F]	-23	-10	426,8	1457	367,3	1,01	3,46	0,87	421,5	1,88	10,21
cond. pressure	-20	-4	514,5	1757	442,8	1,12	3,82	0,96	459,6	2,06	12,34
pc= 55/131	-15	5	668,0	2281	574,9	1,28	4,38	1,10	520,5	2,34	16,08
return gas temp	-10	14	850,5	2905	732,0	1,45	4,97	1,25	585,0	2,63	20,57
RGT= 32/90	0	32	1322,1	4515	1137,8	1,83	6,24	1,57	724,0	3,25	32,34
liquid temp	5	41	1620,8	5535	1394,9	2,03	6,94	1,75	797,8	3,58	39,94
Tliq= 55/131	10	50	1967,9	6721	1693,6	2,25	7,69	1,94	874,3	3,93	48,92

## Model

Designation	<b>SC18MFX</b>	<b>220-240V/50Hz</b>	Conf. 4	Sales code:	<b>104G8804</b>
-------------	----------------	----------------------	---------	-------------	-----------------

## Configuration

Motorconfiguration	CSIR
Power supply (nominal)	220-240V/50Hz 1~
Refrigerant	R513A
Application	MBP
Voltage range	187-254V
Starting torque	HST
Approvals	CCC
	EAC
	VDE

## Electrical accessories / wiring diagram

CSIR

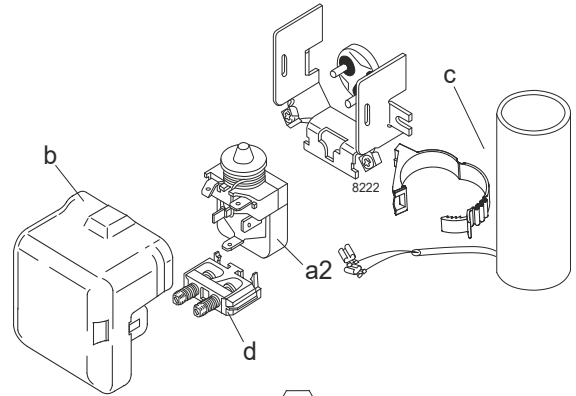

## Ambient/ machine room temperatures minimum /maximum

Ambient temperature range: 10 - 43°C / 50 - 110°F

Machine room temperature range: 10 - 48°C / 50 - 119°F

Compressor cooling: fan 3m/s

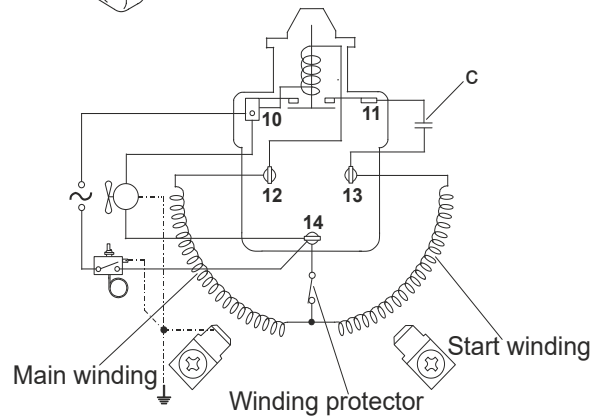

## Operation Limits

### Operation pressure range

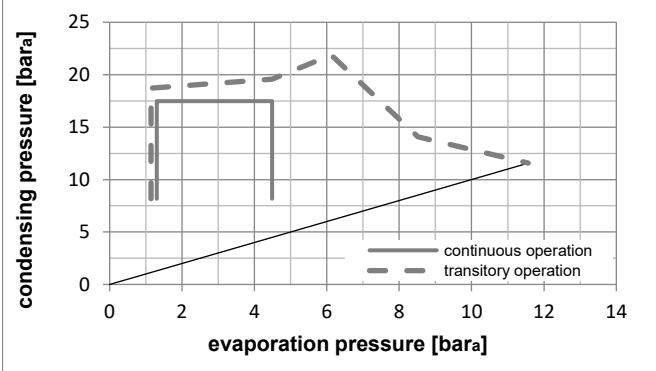
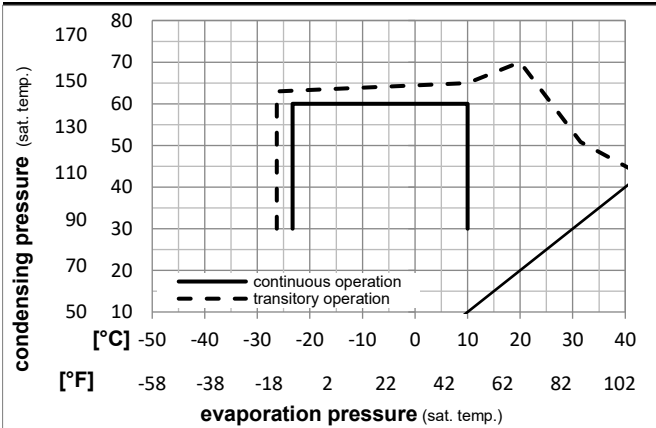

### Components

a2	relay	117U6019
c	start capacitor (80µF)	117U5017
d	cord relief	103N1004
b	plastic cover	103N2008

### Alternative components

a2	relay	117U6019
c	start capacitor i-pack 40# (80µF)	117U5067
d	cord relief	103N1004
b	plastic cover	103N2008

## Model

Designation **SC18MFX** **220-240V/50Hz** Conf. 4 Sales code: **104G8804**

## Optimization + standard conditions

R513A, 220V/50Hz, CSIR, fan 3m/s, CCC, EAC, VDE

		Evaporating pressure (saturation temperature)				Cooling capacity			COP	EER	Power consumption				
		Condensing pressure (saturation temperature)				Return gas temp.					Current consumption				
		Liquid temp.				Cooling capacity					Ref. mass flow				
		pe	pc	RGT	Tliq	[W]	[Btu/h]	[kcal/h]	[W/W]	[Btu/Wh]	[kcal/Wh]	P1	I	m	
[°C]	[°F]	[°C]	[°F]	[°C]	[°C]							[W]	[A]	[kg/h]	
-7	20	54	130	35	46	963,3	3290	829,1	1,61	5,48	1,38	600,0	3,71	23,60	ASHRAE MBP
-10	14	55	131	32	55	736,0	2514	633,4	1,30	4,45	1,12	564,8	3,59	20,35	cecomaf MBP
-10	14	45	113	20	45	829,5	2833	713,9	1,56	5,31	1,34	533,3	3,47	21,99	EN12900 MBP
-7	20	49	120	18	49	895,7	3059	770,8	1,55	5,30	1,33	577,5	3,63	25,24	ARI540 MBP
-10	14	45	113	32	45	867,4	2962	746,5	1,63	5,56	1,40	533,3	3,47	21,33	opt
-25	-13	45	113	32	45	411,2	1404	353,9	1,03	3,52	0,89	398,7	2,99	10,02	opt

## Performance tables

R513A, 220V/50Hz, CSIR, fan 3m/s, CCC, EAC, VDE

	pe		Cooling capacity			COP	EER		P1	I	m
	[°C]	[°F]	[W]	[Btu/h]	[kcal/h]	[W/W]	[Btu/Wh]	[kcal/Wh]	[W]	[A]	[kg/h]
[°C / °F]	-23	-10	451,3	1541	388,4	1,09	3,72	0,94	414,4	3,04	11,01
cond. pressure	-20	-4	536,7	1833	461,9	1,21	4,13	1,04	444,4	3,15	13,11
pc= 45/113	-15	5	687,6	2348	591,7	1,41	4,80	1,21	489,0	3,31	16,85
return gas temp.	-10	14	867,4	2962	746,5	1,63	5,56	1,40	533,3	3,47	21,33
RGT= 32/90	0	32	1329,8	4541	1144,4	2,13	7,27	1,83	624,3	3,80	32,98
liquid temp	5	41	1619,9	5532	1394,1	2,41	8,23	2,07	672,5	3,97	40,40
Tliq= 45/113	10	50	1954,3	6674	1681,9	2,70	9,22	2,32	723,6	4,16	49,07
[°C / °F]	-23	-10	377,9	1290	325,2	0,91	3,11	0,78	415,6	3,05	10,36
cond. pressure	-20	-4	451,7	1543	388,7	1,00	3,41	0,86	452,9	3,18	12,40
pc= 55/131	-15	5	581,4	1986	500,4	1,14	3,90	0,98	508,9	3,38	16,02
return gas temp	-10	14	736,0	2514	633,4	1,30	4,45	1,12	564,8	3,59	20,35
RGT= 32/90	0	32	1135,0	3876	976,8	1,67	5,70	1,44	679,5	4,00	31,70
liquid temp	5	41	1387,1	4737	1193,8	1,87	6,40	1,61	739,9	4,22	38,98
Tliq= 55/131	10	50	1679,4	5736	1445,3	2,09	7,14	1,80	803,3	4,44	47,55

## Model

Designation	<b>SC18MFX</b>	<b>208-230V/60Hz</b>	<b>Conf. 5</b>	Sales code:	<b>104G8804</b>
-------------	----------------	----------------------	----------------	-------------	-----------------

## Configuration

Motorconfiguration	CSCR
Power supply (nominal)	208-230V/60Hz 1~
Refrigerant	R513A
Application	MBP
Voltage range	187-254V
Starting torque	HST
Approvals	CCC
	EAC
	VDE

## Electrical accessories / wiring diagram

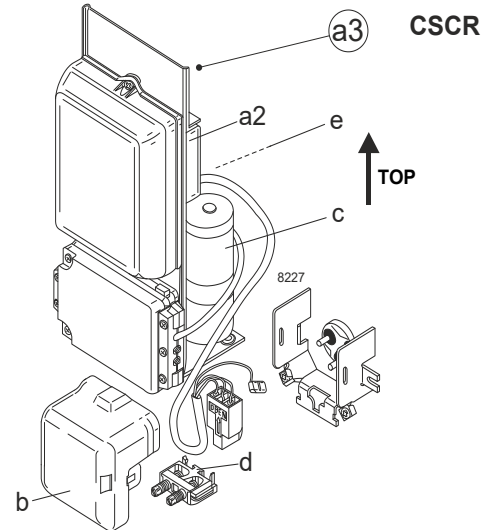

## Ambient/ machine room temperatures minimum /maximum

Ambient temperature range: 10 - 43°C / 50 - 110°F

Machine room temperature range: 10 - 48°C / 50 - 119°F

Compressor cooling: fan 3m/s

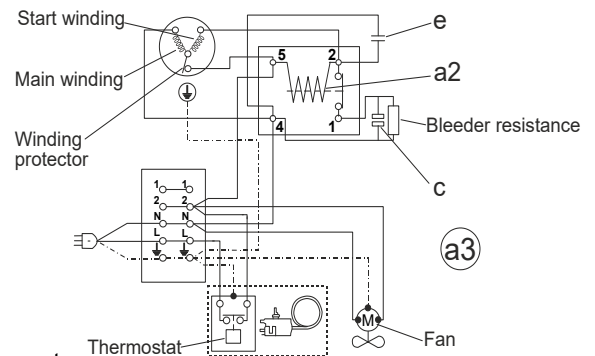

## Operation Limits

### Operation pressure range

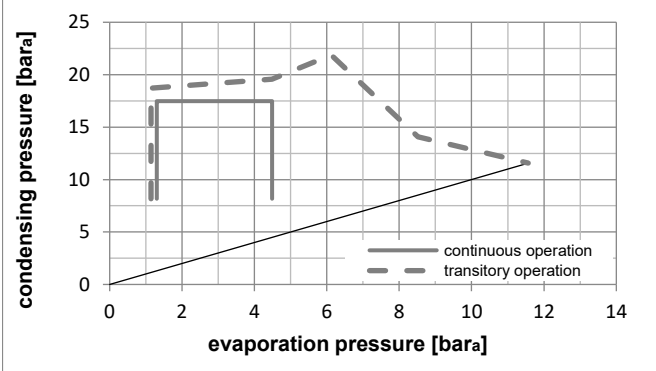
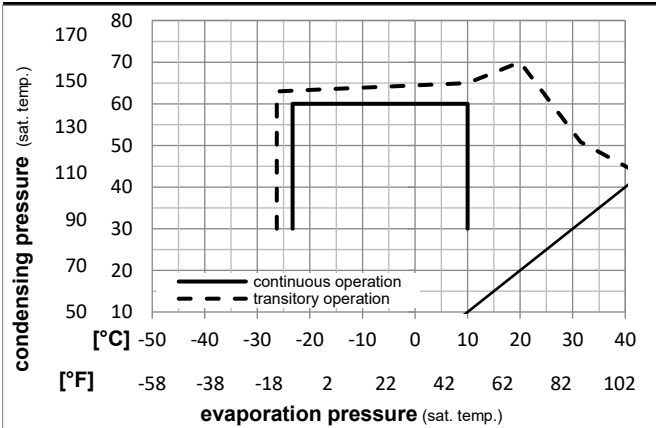

### Components

a3	SC starter kit (550mm)	117-7027
b	plastic cover	103N2008
d	cord relief	103N1004

### Alternative components

a3	SC starter kit (1000mm)	117-7040
b	plastic cover	103N2008
d	cord relief	103N1004

### Model

Designation **SC18MFX** **208-230V/60Hz** Conf. 5 Sales code: **104G8804**

### Optimization + standard conditions

R513A, 220V/60Hz, CSCR, fan 3m/s, CCC, EAC, VDE

		Evaporating pressure (saturation temperature)				Condensing pressure (saturation temperature)					Power consumption				
		Return gas temp.		Liquid temp.		Cooling capacity			COP	EER	P1	I	Ref. mass flow		
		pe	pc	RGT	Tliq	[W]	[Btu/h]	[kcal/h]	[W/W]	[Btu/Wh]	[kcal/Wh]	[W]	[A]	[kg/h]	
[°C]	-7	54	35	46	1153,1	3938	992,4	1,73	5,92	1,49	665,7	3,10	28,24	<b>ASHRAE MBP</b>	
[°F]	20	130	95	115											
[°C]	-10	55	32	55	884,3	3020	761,1	1,42	4,85	1,22	622,9	2,90	24,45	<b>cecomaf MBP</b>	
[°F]	14	131	90	131											
[°C]	-10	45	20	45	992,1	3388	853,8	1,68	5,75	1,45	589,5	2,75	26,29	<b>EN12900 MBP</b>	
[°F]	14	113	68	113											
[°C]	-7	49	18	49	1069,7	3653	920,6	1,66	5,67	1,43	644,3	3,00	30,14	<b>ARI540 MBP</b>	
[°F]	20	120	65	120											
[°C]	-10	45	32	45	1037,4	3543	892,8	1,76	6,01	1,51	589,5	2,75	25,51	<b>opt</b>	
[°F]	14	113	90	113											
[°C]	-25	45	32	45	499,2	1705	429,6	1,17	4,01	1,01	425,4	1,99	12,17	<b>opt</b>	
[°F]	-13	113	90	113											

### Performance tables

R513A, 220V/60Hz, CSCR, fan 3m/s, CCC, EAC, VDE

	pe		Cooling capacity			COP	EER		P1	I	m
	[°C]	[°F]	[W]	[Btu/h]	[kcal/h]	[W/W]	[Btu/Wh]	[kcal/Wh]	[W]	[A]	[kg/h]
[°C / °F]	-23	-10	547,1	1868	470,8	1,24	4,22	1,06	442,9	2,07	13,34
cond. pressure	-20	-4	648,6	2215	558,2	1,36	4,64	1,17	477,6	2,23	15,85
pc= 45/113	-15	5	826,5	2823	711,3	1,55	5,30	1,34	532,4	2,49	20,25
return gas temp.	-10	14	1037,4	3543	892,8	1,76	6,01	1,51	589,5	2,75	25,51
RGT= 32/90	0	32	1576,7	5385	1356,9	2,22	7,59	1,91	709,1	3,30	39,11
liquid temp	5	41	1914,1	6537	1647,3	2,48	8,48	2,14	771,1	3,58	47,74
Tliq= 45/113	10	50	2302,9	7865	1981,9	2,76	9,43	2,38	834,0	3,87	57,82
[°C / °F]	-23	-10	460,2	1572	396,1	1,00	3,42	0,86	459,6	2,15	12,61
cond. pressure	-20	-4	548,7	1874	472,2	1,10	3,77	0,95	497,6	2,33	15,07
pc= 55/131	-15	5	702,5	2399	604,6	1,26	4,30	1,08	558,4	2,61	19,35
return gas temp	-10	14	884,3	3020	761,1	1,42	4,85	1,22	622,9	2,90	24,45
RGT= 32/90	0	32	1350,0	4611	1161,9	1,77	6,06	1,53	761,4	3,54	37,70
liquid temp	5	41	1643,1	5611	1414,0	1,97	6,72	1,69	834,9	3,88	46,17
Tliq= 55/131	10	50	1982,3	6770	1706,0	2,18	7,43	1,87	910,8	4,23	56,12



# SC Compressors

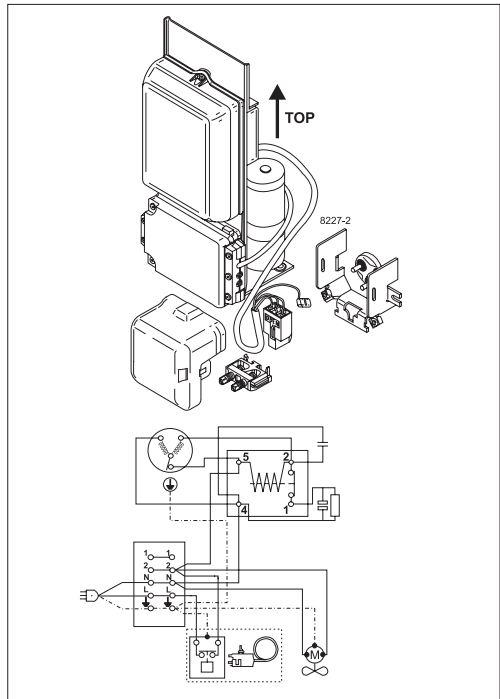
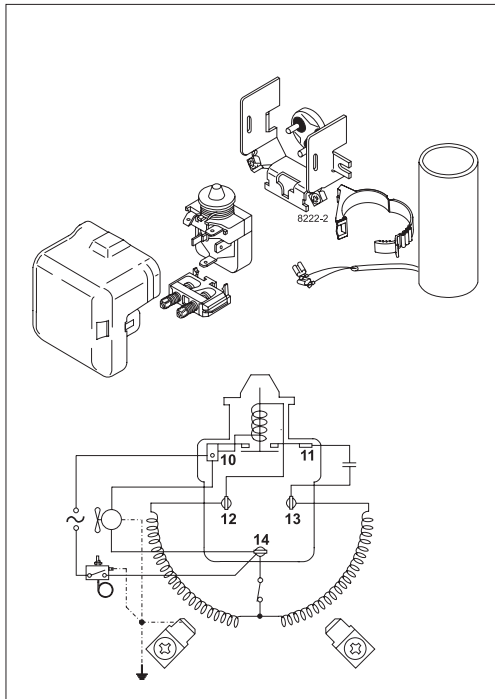
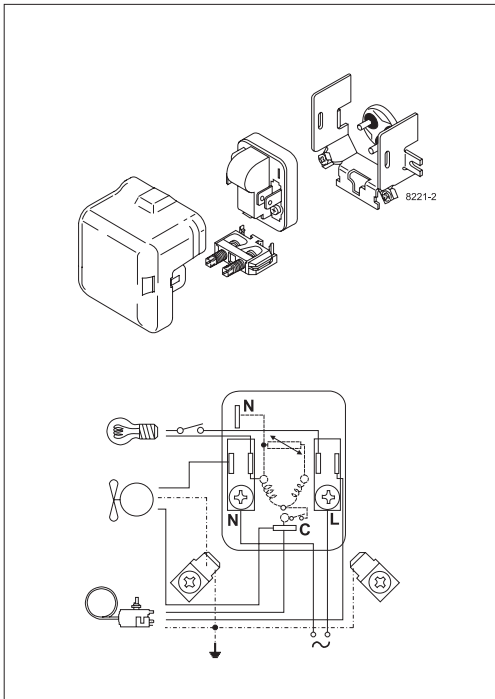



# SC Compressors

## Service/Repair – R290



8545



Secop accepts no responsibility for possible errors in catalogs, brochures, and other printed material. Secop reserves the right to alter its products without notice. This also applies to products already on order provided that such alterations can be made without subsequent changes being necessary to specifications already agreed. All trademarks in this material are the property of the respective companies. Secop and the Secop logotype are trademarks of Secop GmbH. All rights reserved. [www.secop.com](http://www.secop.com)