

Single Pack TL2.5G 220-240V 50/60Hz CSIR

Codice Imballo Singolo: **195B4265**

Posizione	Titolo	Codice	Quantità
1	Compressor TL2.5G	102G4250	1
2	Starting relay	117U6007	1
3	Starting capacitor (60 μ F 220V, 6.3mm)	117U5014	1
4	Cord relief	103N1010	1
5	Cover	103N2011	1
6	Bolt joint for one compressor M6 \varnothing 16mm	118-1917	1

Secop GmbH • Lise-Meitner-Straße 29 • 24941 Flensburg, Germany • Tel: +49 46149410 • www.secop.com

Secop non si assume alcuna responsabilità per eventuali errori presenti in cataloghi, brochure e altro materiale stampato. Secop si riserva il diritto di modificare i propri prodotti senza preavviso. Ciò vale anche per i prodotti già ordinati, a condizione che tali modifiche possano essere apportate senza che siano necessarie modifiche successive alle specifiche già concordate. Tutti i marchi presenti in questo materiale sono di proprietà delle rispettive aziende. Secop e il logo Secop sono marchi di Secop GmbH. Tutti i diritti sono riservati.

TL2.5G Universal Compressor R134a 220-240V 50/60Hz

General

Code number	102G4250
Approvals	EN 60335-2-34 Annex AA , UL984
Compressors on pallet	125

Application

Application	LBP/HBP			
Frequency	Hz	50	60	
Evaporating temperature	°F	-31 to 59	-31 to 59	
Voltage range	V	187 - 254	198 - 254	
Max. condensing temperature continuous (short)	°F	140 (158)	140 (158)	
Max. winding temperature continuous (short)	°F	257 (275)	257 (275)	

Cooling requirements

Frequency	Hz	50			60		
Application		LBP	MBP	HBP	LBP	MBP	HBP
90°F		S	S	S	S	S	S
100°F		S	S	S	S	S	S
110°F		S	S	F ₂	S	S	F ₂
Remarks on application: HBP 50Hz: 198 - 254V HBP 60Hz: 207 - 254V							

Motor

Motor type	RSIR/CSIR		
LRA (rated after 4 sec. UL984), HST LST	A	4.5	2.8
Cut in Current, HST LST	A	4.5	7.2
Resistance, main start winding (77°F)	Ω	32.7	15.5

Design

Displacement	cu.in	0.16
Oil quantity (type)	fl.oz.	9.5 (polyolester)
Maximum refrigerant charge	oz.	14.0
Free gas volume in compressor	fl.oz.	54.3
Weight without electrical equipment	lbs.	14.7

Dimensions

Height	inch	A	6.42
		B	6.26
		B1	-
		B2	-
Suction connector	location, I.D. in. angle	C	0.252-0.259 30°
	material comment		Copper Rubber plug
Process connector	location, I.D. in. angle	D	0.252-0.259 31.5°
	material comment		Copper Rubber plug
Discharge connector	location, I.D. in. angle	E	0.189-0.193 90°
	material comment		Copper Rubber plug
Oil cooler connector	location, I.D. in. angle	F	-
	material comment		-
Remarks:			

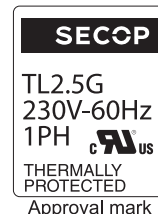
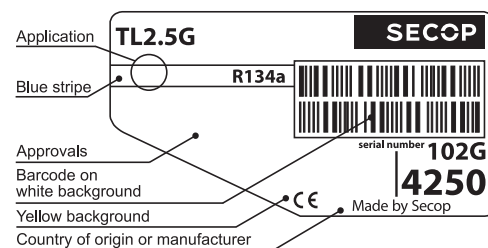

- S = Static cooling normally sufficient
- O = Oil cooling
- F₁ = Fan cooling 1.5 m/s
(compressor compartment temperature equal to ambient temperature)
- F₂ = Fan cooling 3.0 m/s necessary
- SG = Suction gas cooling normally sufficient
- = not applicable in this area

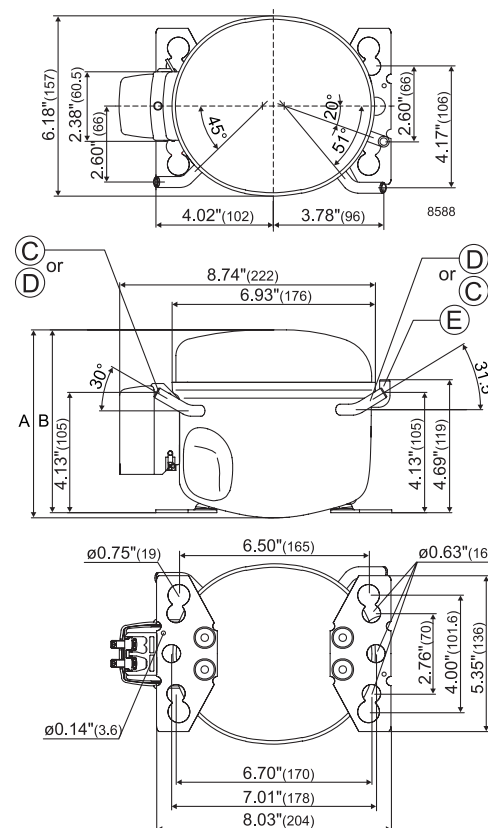

ASHRAE LBP

220V, 50Hz, static cooling

Evap. temp. in °F	-49	-40	-30	-20	-13	-10	0	10	14	20	30	40	41	45	50	59	68
Capacity in BTU/h			53.8	108	152	173	250	342	385	454	588	747	764	836	934	1130	
Power cons. in W			48.1	54.4	59.5	61.9	70.4	79.7	83.7	89.8	101	112	113	117	123	134	
Current cons. in A			0.48	0.49	0.50	0.50	0.52	0.54	0.55	0.57	0.59	0.63	0.63	0.64	0.66	0.69	
EER in BTU/Wh			1.12	1.99	2.56	2.79	3.55	4.29	4.59	5.05	5.85	6.69	6.77	7.13	7.58	8.46	

ASHRAE LBP

220V, 60Hz, static cooling

Evap. temp. in °F	-49	-40	-30	-20	-13	-10	0	10	14	20	30	40	41	45	50	59	68
Capacity in BTU/h			65.6	129	179	203	291	399	447	527	682	865	885	969	1081	1307	
Power cons. in W			53.8	61.3	67.4	70.2	80.3	91.4	96.1	103	116	129	131	136	143	155	
Current cons. in A			0.46	0.47	0.48	0.49	0.50	0.52	0.53	0.55	0.57	0.60	0.61	0.62	0.64	0.67	
EER in BTU/Wh			1.22	2.10	2.66	2.89	3.63	4.36	4.65	5.10	5.87	6.69	6.77	7.12	7.57	8.41	

EN 12900 Household (CECOMAF) 220V, 50Hz, static cooling

Evap. temp. in °F	-49	-40	-30	-20	-13	-10	0	10	14	20	30	40	41	45	50	59	68
Capacity in BTU/h			41.6	85.9	121	138	200	274	308	364	471	598	612	669	747	902	
Power cons. in W			48.1	54.5	59.6	62.0	70.5	79.9	83.9	90.1	101	112	113	118	124	134	
Current cons. in A			0.48	0.49	0.50	0.51	0.52	0.54	0.55	0.57	0.60	0.63	0.63	0.64	0.66	0.70	
EER in BTU/Wh			0.86	1.58	2.03	2.22	2.83	3.43	3.67	4.04	4.67	5.33	5.40	5.68	6.04	6.72	

EN 12900 Household (CECOMAF) 220V, 60Hz, static cooling

Evap. temp. in °F	-49	-40	-30	-20	-13	-10	0	10	14	20	30	40	41	45	50	59	68
Capacity in BTU/h			50.8	102	143	162	234	320	359	423	546	693	709	775	865	1044	
Power cons. in W			53.9	61.4	67.5	70.3	80.4	91.6	96.3	104	116	130	131	137	144	156	
Current cons. in A			0.46	0.47	0.48	0.49	0.50	0.52	0.53	0.55	0.57	0.60	0.61	0.62	0.64	0.67	
EER in BTU/Wh			0.94	1.66	2.12	2.30	2.90	3.49	3.72	4.08	4.69	5.34	5.40	5.67	6.02	6.68	

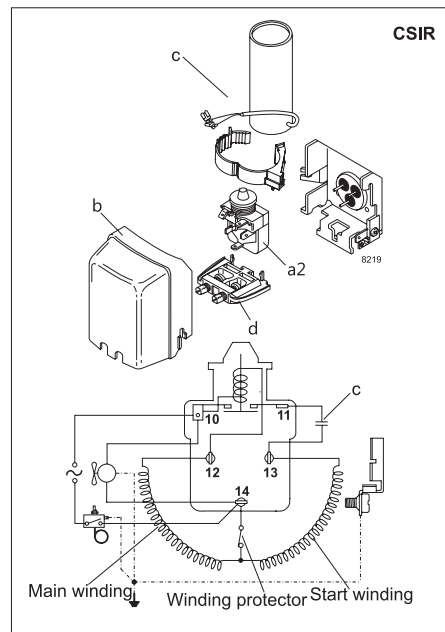
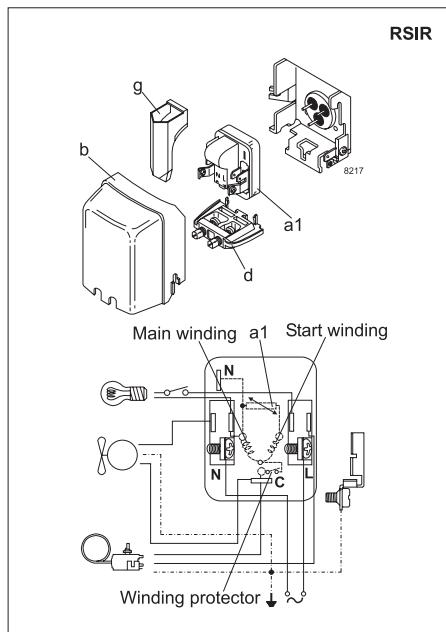

Accessories for	TL2.5G	Figure	Code number
PTC starting device	1/4 in. spade connect.	a1	103N0011
	3/16 in. spade connect.		103N0018
Starting relay	1/4 in. spade connect.	a2	117U6007
Cover		b	103N2011
Start. capacitor 60 µF	1/4 in. spade connect.	c	117U5014
Cord relief		d	103N1010
Protection screen for PTC		g	103N0476

Test conditions	ASHRAE LBP	EN 12900/CECOMAF
Condensing temp.	130°F	131°F
Ambient temp.	90°F	90°F
Suction gas temp	90°F	90°F
Liquid temperature	90°F	no subcooling

Mounting accessories		Code number
Bolt joint for one comp.	Ø: 5/8 in.	118-1917
Bolt joint in quantities	Ø: 5/8 in.	118-1918
Snap-on in quantities	Ø: 5/8 in.	118-1919

Secop accepts no responsibility for possible errors in catalogs, brochures, and other printed material. Secop reserves the right to alter its products without notice. This also applies to products already on order provided that such alterations can be made without substantial changes being necessary to specifications already agreed. All trademarks in this material are the property of the respective companies. Secop and the Secop logotype are trademarks of Secop GmbH. All rights reserved. www.secop.com



TL Compressors

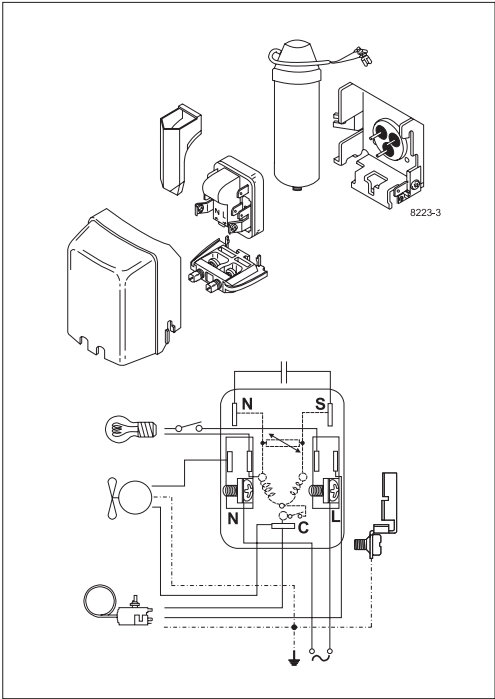
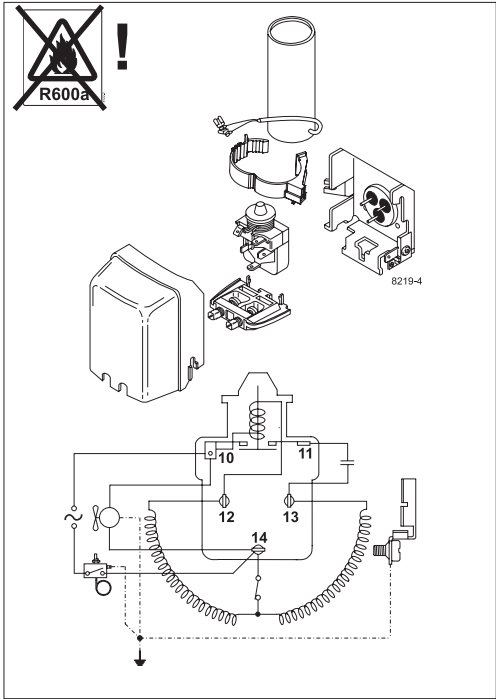
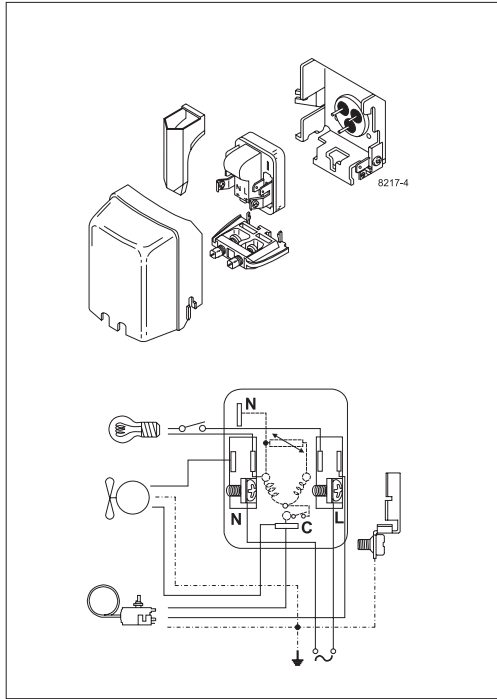



Service/Repair – R600a, R290



8545

Brazing on Suction Connectors (Direct Intake)

representative image



**! max. 150°C/302°F !
at socket**
brazing solder: phosphor (LP7) or silver

Refer to Product Bulletin:
**Brazing on Suction Connectors
(Compressors with Direct Suction Intake)**

Secop accepts no responsibility for possible errors in catalogs, brochures, and other printed material. Secop reserves the right to alter its products without notice. This also applies to products already on order provided that such alterations can be made without subsequential changes being necessary to specifications already agreed. All trademarks in this material are the property of the respective companies. Secop and the Secop logotype are trademarks of Secop GmbH. All rights reserved. www.secop.com