

## Single Pack NLE10MF.2 220-240V 50Hz RSCR

Codice Imballo Singolo: **195B4280**

Posizione	Titolo	Codice	Quantità
1	Compressor NLE10MF.2	105G6187	1
2	e-PTC starting device (220V, 250hm, 4.8mm)	103N0050	1
3	Run capacitor holder	117-0300	1
4	Run capacitor (4μF 320V, 4.8mm)	117-7119	1
5	Cord relief	103N1010	1
6	Cover	103N2010	1
7	Screw for bracket M4x8mm	117-0301	1
8	Bolt joint for one compressor   M6   ø16mm	118-1917	1

**Secop GmbH** • Lise-Meitner-Straße 29 • 24941 Flensburg, Germany • Tel: +49 46149410 • [www.secop.com](http://www.secop.com)

Secop non si assume alcuna responsabilità per eventuali errori presenti in cataloghi, brochure e altro materiale stampato. Secop si riserva il diritto di modificare i propri prodotti senza preavviso. Ciò vale anche per i prodotti già ordinati, a condizione che tali modifiche possano essere apportate senza che siano necessarie modifiche successive alle specifiche già concordate. Tutti i marchi presenti in questo materiale sono di proprietà delle rispettive aziende. Secop e il logo Secop sono marchi di Secop GmbH. Tutti i diritti sono riservati.

**Model**

Designation	<b>NLE10MF.2</b>	<b>220-240V/50Hz 1~</b>	Sales code:	<b>105G6187</b>
-------------	------------------	-------------------------	-------------	-----------------

**Compressor design**

Oil type	Polyolester	Refrigerant(s)	<b>R134a</b>
Oil viscosity	19,2cSt	Displacement	10,09cm <sup>3</sup> / 0,62cu.in
Oil quantity	301cm <sup>3</sup> / 10,2fl.oz	Compressors on pallet	80
Refr. charge - tech. limit	600g / 21,2oz		
Free gas volume comp.	2360cm <sup>3</sup> / 79,8fl.oz		
Weight	10,9kg / 24lbs		
Motor protection	1# internal		
Winding resistance main	9,28Ω (at 25°C)		
Winding resistance aux	11,64Ω (at 25°C)		
Max. winding temp.	125°C / 257°F		
Max. discharge temp.	110°C / 230°F		



**General - Configurations with NLE10MF.2**

	<b>Conf. 1</b>	<b>Conf. 2</b>	<b>Conf. 3</b>
Motorconfiguration	CSIR	RSIR	RSCR
Power supply (nominal)	220-240V/50Hz	220-240V/50Hz	220-240V/50Hz
Number of phases	1	1	1
Voltage range	198-254V	198-254V	198-254V
Approvals	VDE	VDE	VDE
Starting torque	HST	LST	LST
Note	- / -		

**Applications with NLE10MF.2**

	<b>Conf. 1</b>	<b>Conf. 2</b>	<b>Conf. 3</b>
Refrigerant	R134a	R134a	R134a
Application	LBP+MBP	LBP+MBP	LBP+MBP
System cooling	fan 3m/s	fan 3m/s	fan 3m/s
Hot gas defrost	OK	OK	OK
Long interval pull down	OK	OK	OK

**Electrical data - Configurations with NLE10MF.2**

	<b>Conf. 1</b>	<b>Conf. 2</b>	<b>Conf. 3</b>
Starting device type	relay	PTC	PTC
Run capacitor	-/-	-/-	4μF
Start capacitor	80μF	-/-	-/-
LRA (locked rotor amps / 4s)	11,3A	10,7A	10,1A
RLA (rated load amps / 1s)	2,15A	2,15A	2,05A
Cut in current	11,3A	15,9A	15,9A
IP class	21	21	21

**Model**

Designation	<b>NLE10MF.2</b>	<b>220-240V/50Hz 1~</b>	Sales code:	<b>105G6187</b>
-------------	------------------	-------------------------	-------------	-----------------

**Compressor dimensions**

<b>Housing</b>	A Height	203mm / 7,99in
	B Height	197mm / 7,76in
	C Length shell	205mm / 8,07in
	D Length w. cover	254mm / 10in
	E Width	166mm / 6,54in

<b>Connectors</b>		<b>Suction</b>	<b>Discharge</b>	<b>Process</b>
		<b>X</b>	<b>Y</b>	<b>Z</b>
Diameter	[mm]	øi 8,11-8,29	øi 6,11-6,29	øi 6,11-6,29
(i:inside, o:outside)	[in]	øi 0,32-0,33	øi 0,24-0,25	øi 0,24-0,25
Material		copper	copper	copper
Horizontal angle	±2°	0°	0°	0°
Vertical angle	±2°	15°	21°	155°
Position l/h/w	[mm]	132/69/56	94/99/86	-111/92/72
	[in]	5,2/2,7/2,2	3,7/3,9/3,4	-4,4/3,6/2,8
Straight tube l.	[mm]	12	12	12
	[in]	0,5	0,5	0,5

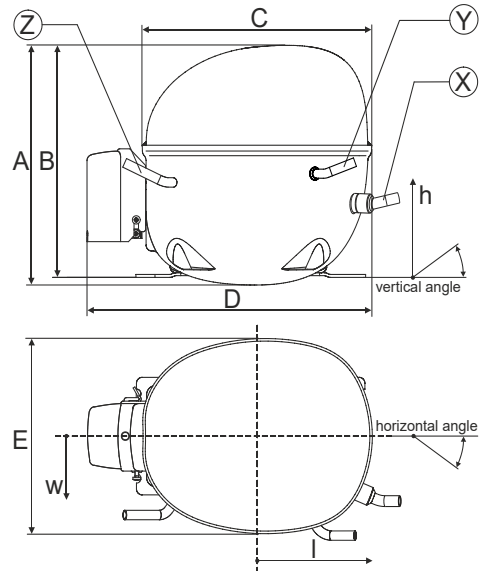

**Compressor fixation**

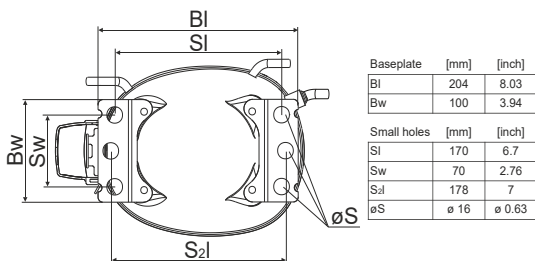

**Bolt joint**

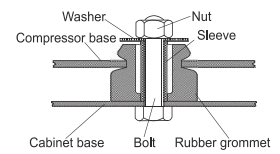

**Snap-on**

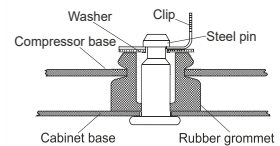

**Mounting accessories**

	one comp.	multi pack
Bolt joint   M6   ø16mm	118-1917	118-1918
Bolt joint   ø1/4"   ø16mm	118-1946	
Snap-on   ø7,3   ø16mm	118-1947	118-1919

**Model**

Designation	<b>NLE10MF.2</b>	<b>220-240V/50Hz</b>	<b>Conf. 1</b>	Sales code:	<b>105G6187</b>
-------------	------------------	----------------------	----------------	-------------	-----------------

**Configuration**

Motorconfiguration	CSIR
Power supply (nominal)	220-240V/50Hz 1~
Refrigerant	R134a
Application	LBP+MBP
Voltage range	198-254V
Starting torque	HST
Approvals	VDE

**Electrical accessories / wiring diagram**

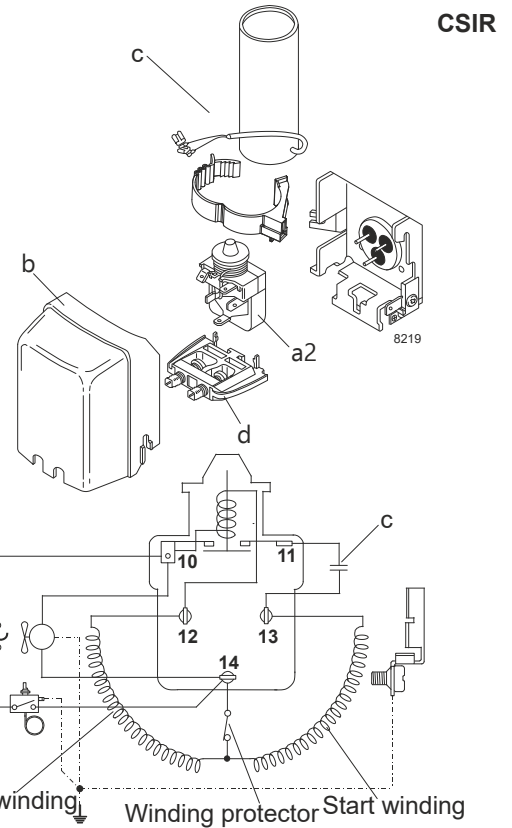

**Ambient temperatures / system cooling**

Ambient temperature min.:	10°C / 50°F
Ambient temperature max.:	43°C / 110°F

System cooling (n/a: outside limits)			
T ambient	LBP	MBP	HBP
32°C / 90°F	fan 3m/s	fan 3m/s	n/a
38°C / 100°F	fan 3m/s	fan 3m/s	n/a
43°C / 110°F	fan 3m/s	fan 3m/s	n/a

**Operation pressure range**

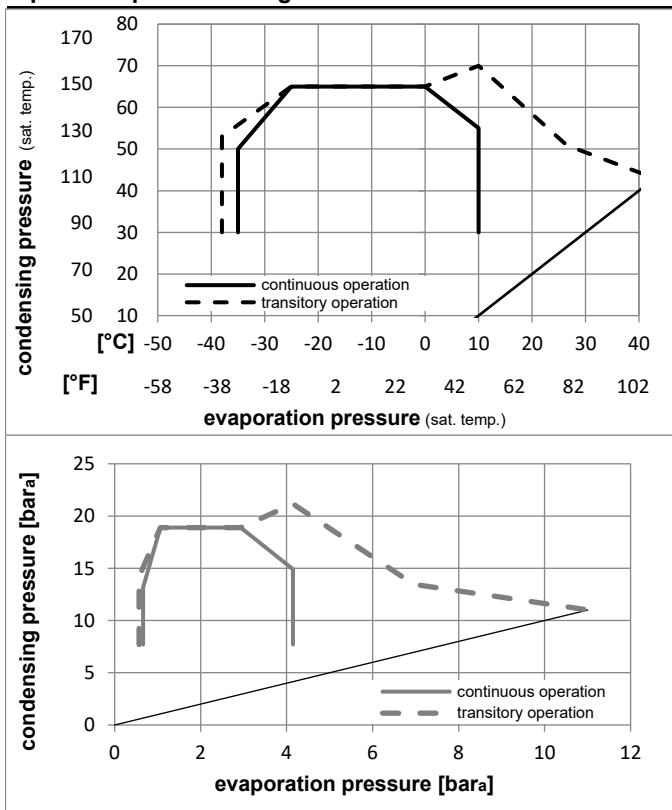

**Components**

a2	assy. relay	117U6002
c	start capacitor (80µF)	117U5015
b	plastic cover	103N2010
d	cord relief	103N1010

**Alternative components**

b	plastic cover	103N2011
---	---------------	----------

**Model**

Designation **NLE10MF.2 220-240V/50Hz** Conf. 1 Sales code: **105G6187**

**Optimization + standard conditions**

220-240V/50Hz 1~, CSIR, fan 3m/s, VDE

	Evaporating pressure (saturation temperature)				Condensing pressure (saturation temperature)						Power consumption			ASHRAE MBP				
	pe	pc	RGT	Tliq	Cooling capacity			COP	EER		P1	I	Ref. mass flow					
	[°C]	[°F]	[°C]	[°F]	[W]	[Btu/h]	[kcal/h]	[W/W]	[Btu/Wh]	[kcal/Wh]	[W]	[A]	[kg/h]					
	-6,66	20	54,4	130	35	95	46,1	115	609,2	2081	524,3	1,94	6,64	1,67	313,4	1,89	13,29	ASHRAE MBP
	-10	14	55	131	32	89,6	55	131	471,1	1609	405,5	1,62	5,54	1,40	290,4	1,81	11,39	cecomaf MBP
	-10	14	45	113	20	68	45	113	535,9	1830	461,2	1,99	6,79	1,71	269,6	1,75	12,54	EN12900 MBP
	-6,66	20	48,9	120	18,3	65	48,9	120	581,4	1986	500,4	1,95	6,65	1,67	298,7	1,84	14,36	ARI540 MBP
	-10	14	45	113	32	89,6	45	113	556,0	1899	478,5	2,06	7,04	1,78	269,6	1,75	12,17	opt
	-25	-13	45	113	32	89,6	45	113	262,5	897	225,9	1,38	4,72	1,19	190,0	1,52	5,69	opt

**Performance tables**

220-240V/50Hz 1~, CSIR, fan 3m/s, VDE

	pe	Cooling capacity			COP			EER			P1	I	m
	[°C]	[°F]	[W]	[Btu/h]	[kcal/h]	[W/W]	[Btu/Wh]	[kcal/Wh]	[W]	[A]	[kg/h]		
[°C / °F]	-35	-31	134,3	459	115,5	0,94	3,21	0,81	143,0	1,43	2,90		
cond. pressure	-25	-13	262,5	897	225,9	1,38	4,72	1,19	190,0	1,52	5,69		
pc= 45/113	-15	5	440,7	1505	379,3	1,82	6,23	1,57	241,7	1,66	9,61		
return gas temp.	-10	14	556,0	1899	478,5	2,06	7,04	1,78	269,6	1,75	12,17		
RGT= 32/90	0	32	853,8	2916	734,8	2,59	8,84	2,23	330,0	1,96	18,88		
liquid temp	5	41	1042,4	3560	897,1	2,87	9,81	2,47	362,9	2,08	23,21		
Tliq= 45/113	10	50	1261,3	4308	1085,5	3,17	10,83	2,73	397,6	2,20	28,30		
[°C / °F]	-35	-31	93,5	319	80,5	0,75	2,56	0,65	124,6	1,40	2,23		
cond. pressure	-25	-13	210,5	719	181,1	1,12	3,83	0,96	187,9	1,51	5,03		
pc= 55/131	-15	5	368,9	1260	317,5	1,45	4,94	1,24	255,0	1,69	8,88		
return gas temp	-10	14	471,1	1609	405,5	1,62	5,54	1,40	290,4	1,81	11,39		
RGT= 32/90	0	32	736,6	2516	633,9	2,02	6,89	1,74	365,3	2,08	18,02		
liquid temp	5	41	905,7	3093	779,5	2,24	7,64	1,92	405,1	2,24	22,32		
Tliq= 55/131	10	50	1103,2	3768	949,4	2,47	8,44	2,13	446,6	2,41	27,42		

**Model**

Designation	<b>NLE10MF.2</b>	<b>220-240V/50Hz</b>	<b>Conf. 2</b>	Sales code:	<b>105G6187</b>
-------------	------------------	----------------------	----------------	-------------	-----------------

**Configuration**

Motorconfiguration	RSIR
Power supply (nominal)	220-240V/50Hz 1~
Refrigerant	R134a
Application	LBP+MBP
Voltage range	198-254V
Starting torque	LST
Approvals	VDE

**Electrical accessories / wiring diagram**

RSIR

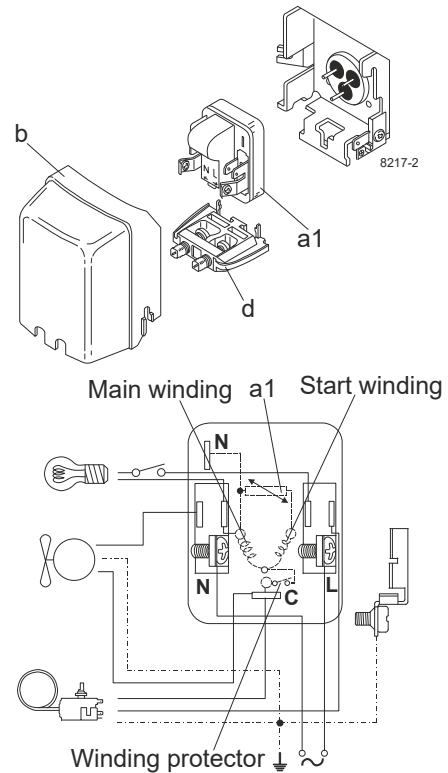

**Ambient temperatures / system cooling**

Ambient temperature min.:	10°C / 50°F
Ambient temperature max.:	43°C / 110°F

System cooling (n/a: outside limits)			
T ambient	LBP	MBP	HBP
32°C / 90°F	fan 3m/s	fan 3m/s	n/a
38°C / 100°F	fan 3m/s	fan 3m/s	n/a
43°C / 110°F	fan 3m/s	fan 3m/s	n/a

**Operation pressure range**

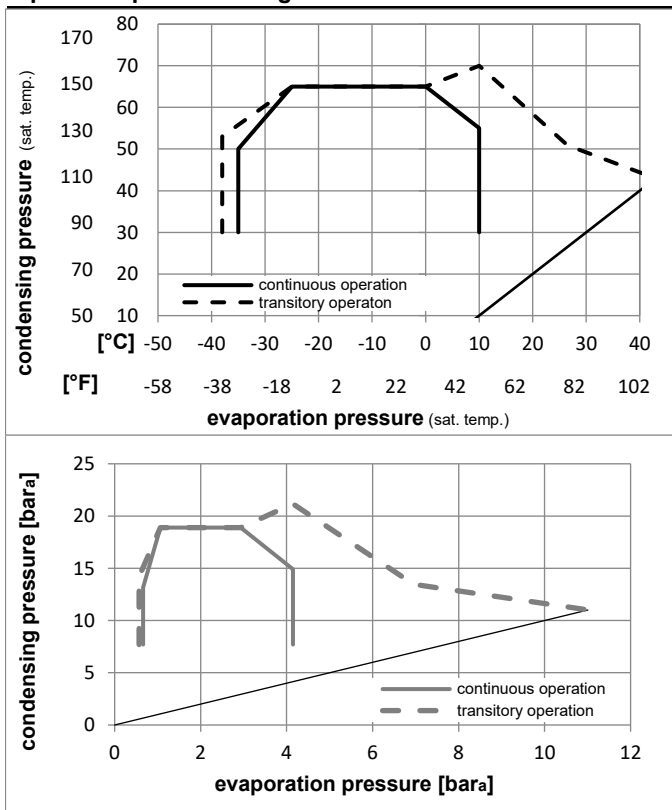

Components

a1	e-PTC starter (220V, 250hm, 4.8mm)	103N0050
b	plastic cover	103N2010
d	cord relief	103N1010

Alternative components

b	plastic cover	103N2011
---	---------------	----------

**Model**

Designation **NLE10MF.2 220-240V/50Hz** Conf. **2** Sales code: **105G6187**

**Optimization + standard conditions**

220-240V/50Hz 1~, RSIR, fan 3m/s, VDE

		Evaporating pressure (saturation temperature)				Condensing pressure (saturation temperature)						Power consumption			
		Return gas temp.		Liquid temp.		Cooling capacity				COP	EER	P1	I	Ref. mass flow	
		pe	pc	RGT	Tliq	[W]	[Btu/h]	[kcal/h]	[W/W]	[Btu/Wh]	[kcal/Wh]	[W]	[A]	[kg/h]	
[°C]	-6,66	54,4	35	46,1	609,2	2081	524,3	1,94	6,64	1,67	313,4	1,89	13,29	ASHRAE MBP	
[°F]	20	130	95	115											
[°C]	-10	55	32	55	471,1	1609	405,5	1,62	5,54	1,40	290,4	1,81	11,39	cecomaf MBP	
[°F]	14	131	89,6	131											
[°C]	-10	45	20	45	535,9	1830	461,2	1,99	6,79	1,71	269,6	1,75	12,54	EN12900 MBP	
[°F]	14	113	68	113											
[°C]	-6,66	48,9	18,3	48,9	581,4	1986	500,4	1,95	6,65	1,67	298,7	1,84	14,36	ARI540 MBP	
[°F]	20	120	65	120											
[°C]	-10	45	32	45	556,0	1899	478,5	2,06	7,04	1,78	269,6	1,75	12,17	opt	
[°F]	14	113	89,6	113											
[°C]	-25	45	32	45	262,5	897	225,9	1,38	4,72	1,19	190,0	1,52	5,69	opt	
[°F]	-13	113	89,6	113											

**Performance tables**

220-240V/50Hz 1~, RSIR, fan 3m/s, VDE

		pe	Cooling capacity			COP	EER	P1	I	m		
		[°C]	[°F]	[W]	[Btu/h]	[kcal/h]	[W/W]	[Btu/Wh]	[kcal/Wh]	[W]	[A]	[kg/h]
[°C / °F]	-35	-31	134,3	459	115,5	0,94	3,21	0,81	143,0	1,43	2,90	
cond. pressure	-25	-13	262,5	897	225,9	1,38	4,72	1,19	190,0	1,52	5,69	
pc= 45/113	-15	5	440,7	1505	379,3	1,82	6,23	1,57	241,7	1,66	9,61	
return gas temp.	-10	14	556,0	1899	478,5	2,06	7,04	1,78	269,6	1,75	12,17	
RGT= 32/90	0	32	853,8	2916	734,8	2,59	8,84	2,23	330,0	1,96	18,88	
liquid temp	5	41	1042,4	3560	897,1	2,87	9,81	2,47	362,9	2,08	23,21	
Tliq= 45/113	10	50	1261,3	4308	1085,5	3,17	10,83	2,73	397,6	2,20	28,30	
[°C / °F]	-35	-31	93,5	319	80,5	0,75	2,56	0,65	124,6	1,40	2,23	
cond. pressure	-25	-13	210,5	719	181,1	1,12	3,83	0,96	187,9	1,51	5,03	
pc= 55/131	-15	5	368,9	1260	317,5	1,45	4,94	1,24	255,0	1,69	8,88	
return gas temp	-10	14	471,1	1609	405,5	1,62	5,54	1,40	290,4	1,81	11,39	
RGT= 32/90	0	32	736,6	2516	633,9	2,02	6,89	1,74	365,3	2,08	18,02	
liquid temp	5	41	905,7	3093	779,5	2,24	7,64	1,92	405,1	2,24	22,32	
Tliq= 55/131	10	50	1103,2	3768	949,4	2,47	8,44	2,13	446,6	2,41	27,42	

**Model**

Designation	<b>NLE10MF.2</b>	<b>220-240V/50Hz</b>	<b>Conf. 3</b>	Sales code:	<b>105G6187</b>
-------------	------------------	----------------------	----------------	-------------	-----------------

**Configuration**

Motorconfiguration	RSCR
Power supply (nominal)	220-240V/50Hz 1~
Refrigerant	R134a
Application	LBP+MBP
Voltage range	198-254V
Starting torque	LST
Approvals	VDE

**Electrical accessories / wiring diagram**

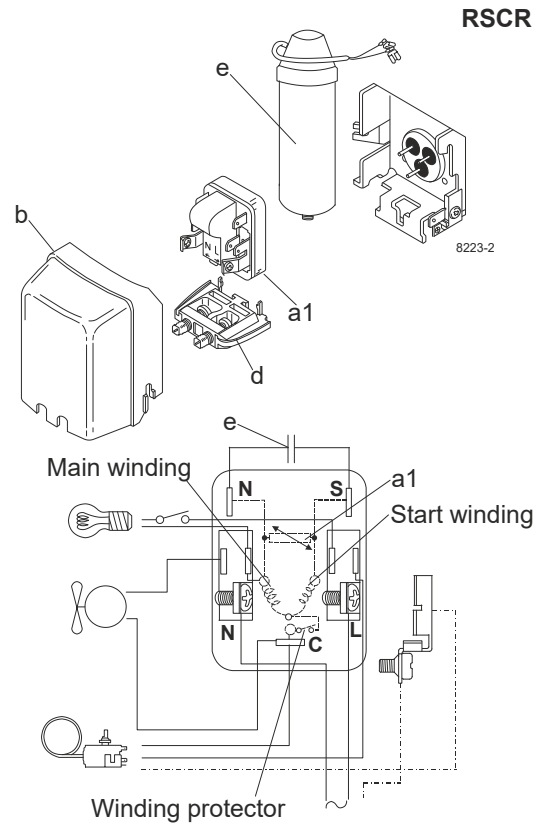

**Ambient temperatures / system cooling**

Ambient temperature min.:	10°C / 50°F
Ambient temperature max.:	43°C / 110°F

System cooling (n/a: outside limits)			
T ambient	LBP	MBP	HBP
32°C / 90°F	fan 3m/s	fan 3m/s	n/a
38°C / 100°F	fan 3m/s	fan 3m/s	n/a
43°C / 110°F	fan 3m/s	fan 3m/s	n/a

**Operation pressure range**

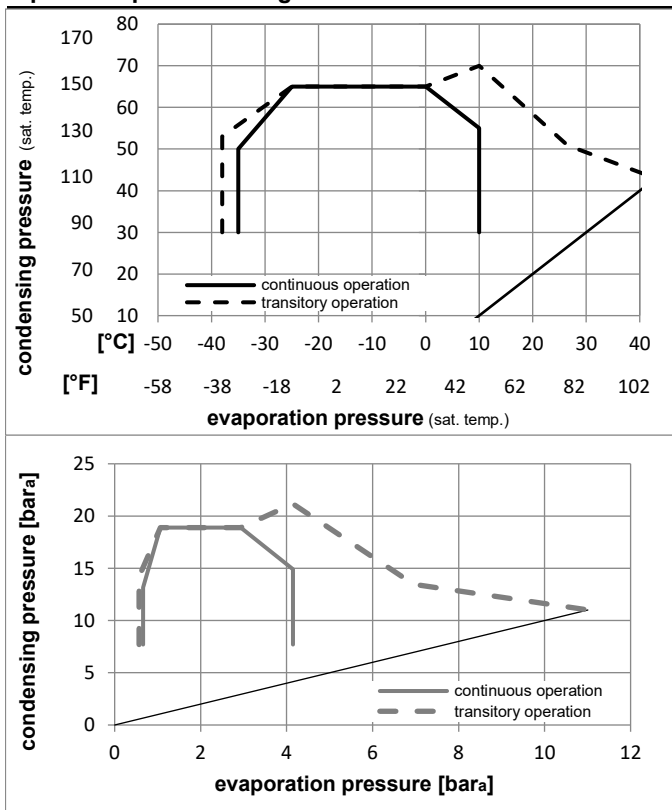

**Components**

a1	e-PTC starter (220V, 250hm, 4.8mm)	103N0050
e	run capacitor (4μF, 4.8mm)	117-7119
b	plastic cover	103N2010
d	cord relief	103N1010
	bracket for run capacitor	117-0300
	screw M4x8mm	117-0301

**Alternative components**

b	plastic cover	103N2011
---	---------------	----------



**Model**

Designation **NLE10MF.2 220-240V/50Hz** Conf. **3** Sales code: **105G6187**

**Optimization + standard conditions**

220-240V/50Hz 1~, RSCR, fan 3m/s, VDE

		Evaporating pressure (saturation temperature)				Condensing pressure (saturation temperature)						Power consumption			
		Return gas temp.		Liquid temp.		Cooling capacity				COP	EER	P1	I	Ref. mass flow	
	pe	pc	RGT	Tliq	[W]	[Btu/h]	[kcal/h]	[W/W]	[Btu/Wh]	[kcal/Wh]	[W]	[A]	[kg/h]		
[°C]	-6,66	54,4	35	46,1	608,5	2078	523,7	2,05	6,99	1,76	297,5	1,79	13,28	ASHRAE MBP	
[°F]	20	130	95	115											
[°C]	-10	55	32	55	470,6	1607	405,0	1,71	5,83	1,47	275,6	1,71	11,38	cecomaf MBP	
[°F]	14	131	89,6	131											
[°C]	-10	45	20	45	535,3	1828	460,7	2,09	7,15	1,80	255,8	1,66	12,53	EN12900 MBP	
[°F]	14	113	68	113											
[°C]	-6,66	48,9	18,3	48,9	580,8	1983	499,8	2,05	7,00	1,76	283,5	1,75	14,35	ARI540 MBP	
[°F]	20	120	65	120											
[°C]	-10	45	32	45	555,4	1897	478,0	2,17	7,41	1,87	255,8	1,66	12,15	opt	
[°F]	14	113	89,6	113											
[°C]	-25	45	32	45	262,2	896	225,7	1,45	4,97	1,25	180,3	1,44	5,68	opt	
[°F]	-13	113	89,6	113											

**Performance tables**

220-240V/50Hz 1~, RSCR, fan 3m/s, VDE

	pe	Cooling capacity			COP	EER	P1	I	m		
	[°C]	[°F]	[W]	[Btu/h]	[kcal/h]	[W/W]	[Btu/Wh]	[kcal/Wh]	[W]	[A]	[kg/h]
[°C / °F]	-35	-31	134,1	458	115,4	0,99	3,38	0,85	135,7	1,36	2,89
cond. pressure	-25	-13	262,2	896	225,7	1,45	4,97	1,25	180,3	1,44	5,68
pc= 45/113	-15	5	440,2	1503	378,9	1,92	6,55	1,65	229,4	1,57	9,60
return gas temp.	-10	14	555,4	1897	478,0	2,17	7,41	1,87	255,8	1,66	12,15
RGT= 32/90	0	32	852,9	2913	734,0	2,72	9,30	2,34	313,2	1,86	18,86
liquid temp	5	41	1041,2	3556	896,1	3,02	10,33	2,60	344,4	1,97	23,18
Tliq= 45/113	10	50	1259,9	4303	1084,3	3,34	11,40	2,87	377,3	2,09	28,27
[°C / °F]	-35	-31	93,4	319	80,4	0,79	2,70	0,68	118,3	1,33	2,22
cond. pressure	-25	-13	210,2	718	180,9	1,18	4,03	1,01	178,3	1,43	5,03
pc= 55/131	-15	5	368,5	1258	317,1	1,52	5,20	1,31	242,0	1,60	8,87
return gas temp	-10	14	470,6	1607	405,0	1,71	5,83	1,47	275,6	1,71	11,38
RGT= 32/90	0	32	735,8	2513	633,2	2,12	7,25	1,83	346,7	1,97	18,00
liquid temp	5	41	904,8	3090	778,6	2,35	8,04	2,03	384,5	2,12	22,29
Tliq= 55/131	10	50	1102,0	3764	948,4	2,60	8,88	2,24	423,9	2,28	27,39



8238-20

# NL Compressors

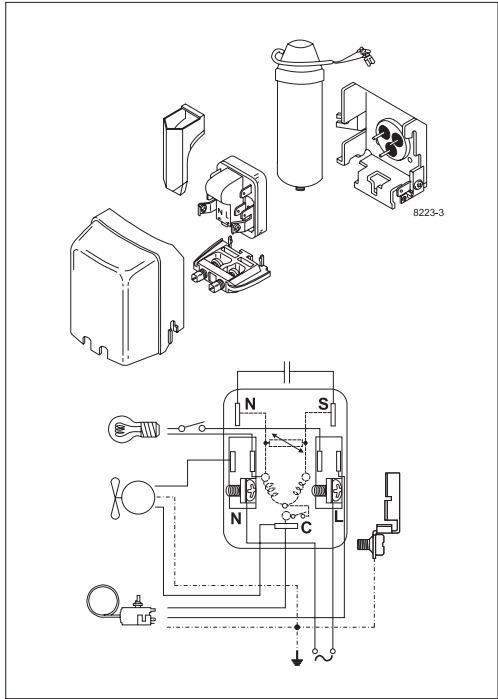
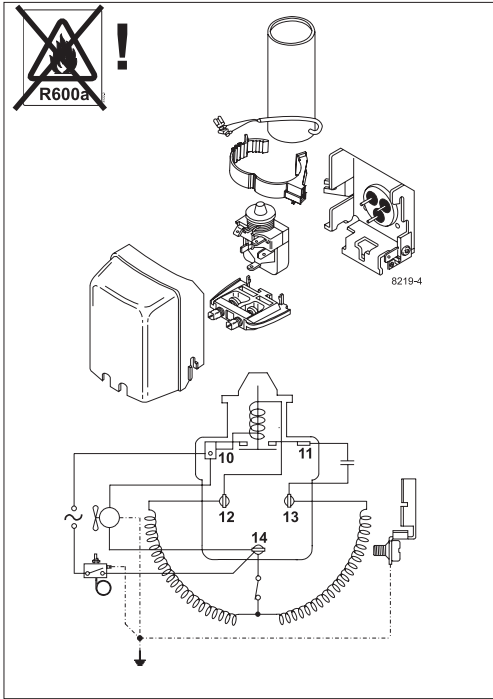
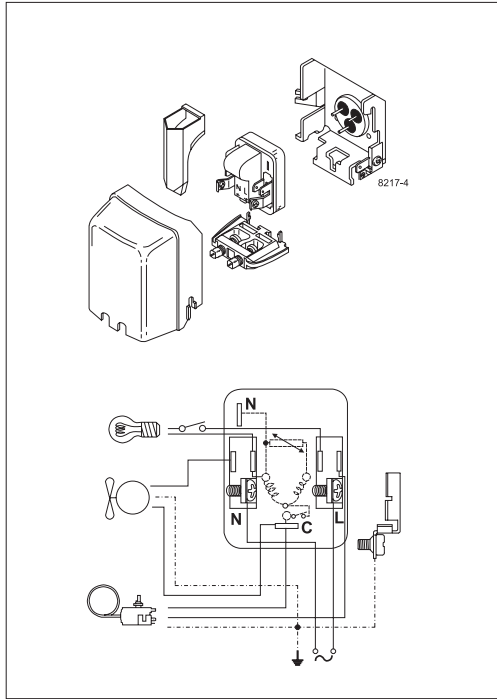



## Service/Repair – R600a, R290



8545

## Brazing on Suction Connectors (Direct Intake)

representative image



**! max. 150°C/302°F !  
at socket**  
brazing solder: phosphor (LP7) or silver

Refer to Product Bulletin:  
**Brazing on Suction Connectors  
(Compressors with Direct Suction Intake)**

Secop accepts no responsibility for possible errors in catalogs, brochures, and other printed material. Secop reserves the right to alter its products without notice. This also applies to products already on order provided that such alterations can be made without subsequential changes being necessary to specifications already agreed. All trademarks in this material are the property of the respective companies. Secop and the Secop logotype are trademarks of Secop GmbH. All rights reserved. [www.secop.com](http://www.secop.com)