

Single Pack NLE8.0CNT 220-230V 50Hz / 208-230V 60Hz CSIR

Codice Imballo Singolo: **195B4315**

Posizione	Titolo	Codice	Quantità
1	Compressor NLE8.0CNT	105H6073	1
2	Starting relay	117U7003	1
3	Starting capacitor (60 μ F 220V, 6.3mm)	117U5014	1
4	Cord relief	103N1010	1
5	Cover	103N2011	1
6	Bolt joint for one compressor M6 \varnothing 16mm	118-1917	1

Secop GmbH • Lise-Meitner-Straße 29 • 24941 Flensburg, Germany • Tel: +49 46149410 • www.secop.com

Secop non si assume alcuna responsabilità per eventuali errori presenti in cataloghi, brochure e altro materiale stampato. Secop si riserva il diritto di modificare i propri prodotti senza preavviso. Ciò vale anche per i prodotti già ordinati, a condizione che tali modifiche possano essere apportate senza che siano necessarie modifiche successive alle specifiche già concordate. Tutti i marchi presenti in questo materiale sono di proprietà delle rispettive aziende. Secop e il logo Secop sono marchi di Secop GmbH. Tutti i diritti sono riservati.

Model

Designation	NLE8.0CNT	220-230V/50Hz 1~ 208-230V/60Hz 1~	Sales code:	105H6073
-------------	------------------	-----------------------------------	-------------	-----------------

Compressor design

Oil type	Polyolester	Refrigerant(s)	R290
Oil viscosity	32cSt	Displacement	7,96cm ³ / 0,49cu.in
Oil quantity	268cm ³ / 9,1fl.oz	Compressors on pallet	80
Refr. charge - tech. limit	400g / 14,1oz		
Free gas volume comp.	2360cm ³ / 79,8fl.oz		
Weight	11,1kg / 24,5lbs		
Motor protection	1# internal		
Winding resistance main	7,68Ω (at 25°C)		
Winding resistance aux	13,88Ω (at 25°C)		
Max. winding temp.	125°C / 257°F		
Max. discharge temp.	120°C / 248°F		



General - Configurations with NLE8.0CNT

	Conf. 1	Conf. 2	Conf. 3	Conf. 4	Conf. 5
Motorconfiguration	CSIR	eRSCR	eRSIR	CSIR	eRSCR
Power supply (nominal)	208-230V/60Hz	208-230V/60Hz	208-230V/60Hz	220-230V/50Hz	220-230V/50Hz
Number of phases	1	1	1	1	1
Voltage range	187-253V	187-253V	187-253V	187-242V	187-242V
Approvals	UL, CCC	UL, CCC	UL, CCC	UL, CCC	UL, CCC
Starting torque	HST	LST	LST	HST	LST
Note	- / -				

Applications with NLE8.0CNT

	Conf. 1	Conf. 2	Conf. 3	Conf. 4	Conf. 5
Refrigerant	R290	R290	R290	R290	R290
Application	LBP+MBP	LBP+MBP	LBP+MBP	LBP+MBP	LBP+MBP
System cooling	fan 3m/s	fan 3m/s	fan 3m/s	fan 3m/s	fan 3m/s
Hot gas defrost	OK	OK	OK	OK	OK
Long interval pull down	OK	OK	OK	OK	OK

Electrical data - Configurations with NLE8.0CNT

	Conf. 1	Conf. 2	Conf. 3	Conf. 4	Conf. 5
Starting device type	relay	e-PTC	e-PTC	relay	e-PTC
Run capacitor	- / -	4μF	- / -	- / -	4μF
Start capacitor	60μF	- / -	- / -	60μF	- / -
LRA (locked rotor amps / 4s/ U(N))	12A	11,8A	11,8A	12,36A	12,4A
RLA (rated load amps / 1s/ U(N))	2,2A	1,8A	2,2A	2,5A	2,1A
Cut in current (U(N))	12A	16,4A	16,4A	12,36A	17,1A

Model

Designation

NLE8.0CNT

220-230V/50Hz 1~ 208-230V/60Hz 1~

Sales code:

105H6073

Compressor dimensions

Housing	A Height	203mm / 7,99in
	B Height	197mm / 7,76in
	C Length shell	205mm / 8,07in
	D Length w. cover	254mm / 10in
	E Width	166mm / 6,54in

Connectors		Suction	Discharge	Process
		X	Y	Z
Diameter	[mm]	øi 8,11-8,29	øi 6,41-6,59	øi 6,41-6,59
(i:inside, o:outside)	[in]	øi 0,32-0,33	øi 0,25-0,26	øi 0,25-0,26
Material		copper	copper	copper
Horizontal angle	±2°	0°	0°	0°
Vertical angle	±2°	15°	21°	155°
Position l/h/w	[mm]	132/69/57	94/102/81	-109/94/72
	[in]	5,2/2,7/2,2	3,7/4/3,2	-4,3/3,7/2,8
Straight tube l.	[mm]	12	12	12
	[in]	0,5	0,5	0,5

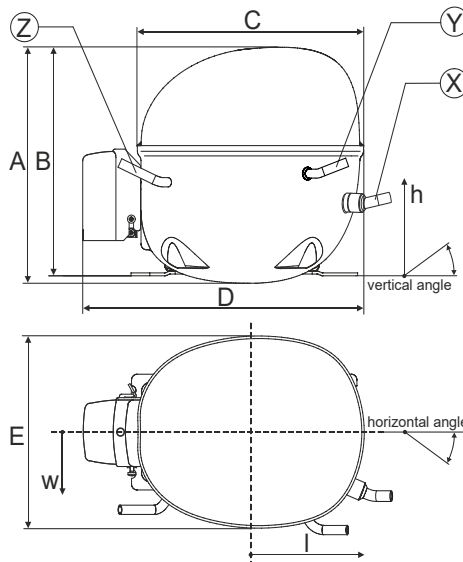

Compressor fixation

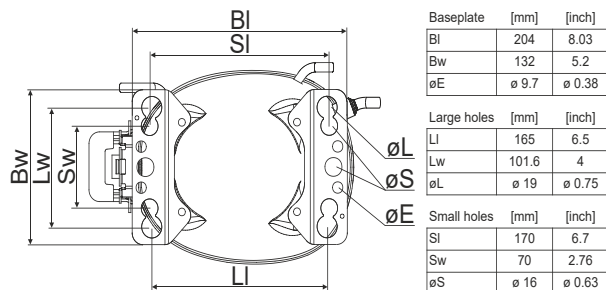

Bolt joint

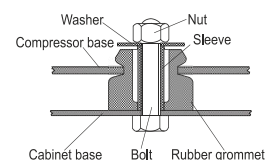

Snap-on

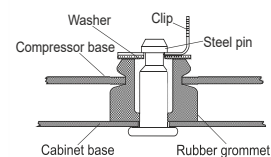

Mounting accessories

	one comp.	multi pack
Bolt joint M6 ø16mm	118-1917	118-1918
Bolt joint ø1/4" ø16mm	118-1946	
Bolt joint ø1/4" ø19mm	118-1949	
Snap-on ø7,3 ø16mm	118-1947	118-1919

#NV

#NV

Provision for PE Grounding is located at the PE Stamp on the compressor

Model

Designation	NLE8.0CNT	208-230V/60Hz	Conf. 1	Sales code:	105H6073
-------------	------------------	----------------------	----------------	-------------	-----------------

Configuration

Motor configuration	CSIR	
Power supply (nominal)	208-230V/60Hz 1~	
Refrigerant	R290	
Application	LBP+MBP	
Voltage range	187-253V	
Starting torque	HST	
Approvals	UL	SA3693
	CCC	

Electrical accessories / wiring diagram

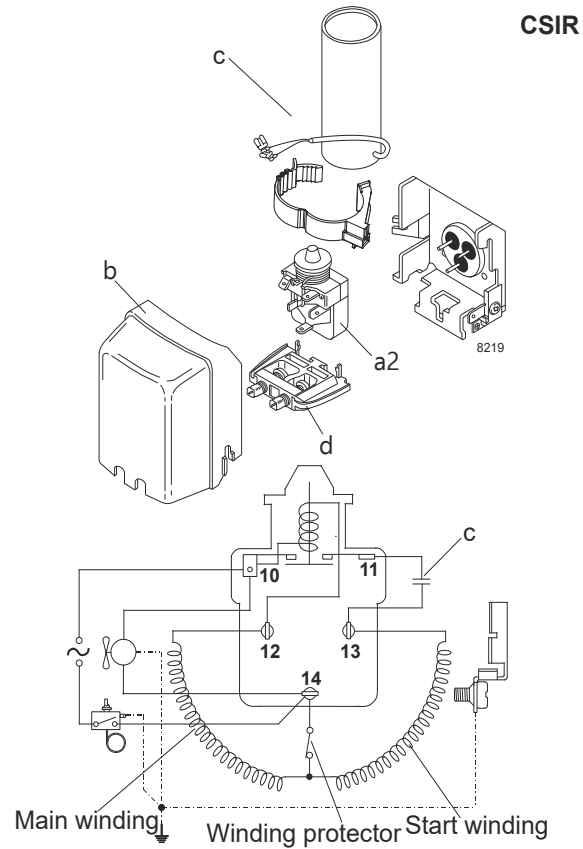

Ambient/ machine room temperatures minimum /maximum

Ambient temperature range:	10 - 43°C / 50 - 110°F
Machine room temperature range:	10 - 48°C / 50 - 119°F
Compressor cooling:	fan 3m/s

Operation pressure range

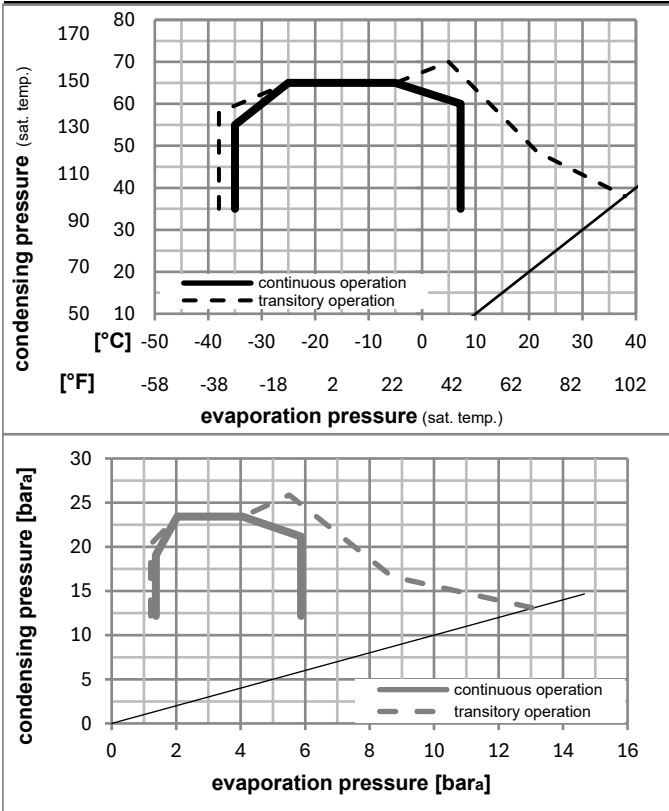

Components

a2	relay	117U7003
c	start capacitor (60μF)	117U5014
b	plastic cover	103N2011
d	cord relief	103N1010

Alternative components

b	plastic cover	103N2010
---	---------------	----------

Model

Designation **NLE8.0CNT** **208-230V/60Hz** Conf. 1 Sales code: **105H6073**

Optimization + standard conditions

R290, 220V/60Hz, CSIR, fan 3m/s, UL, CCC

	Evaporating pressure (saturation temperature)				Cooling capacity			COP	EER	Power consumption			ASHRAE
	pe	pc	RGT	Tliq	[W]	[Btu/h]	[kcal/h]			P1	I	m	
[°C]	[°C]	[°C]	[°C]	[W]	[Btu/h]	[kcal/h]	[W/W]	[Btu/Wh]	[kcal/Wh]	[W]	[A]	[kg/h]	
[°F]	[°F]	[°F]	[°F]	[W]	[Btu/h]	[kcal/h]	[W/W]	[Btu/Wh]	[kcal/Wh]	[W]	[A]	[kg/h]	ASHRAE LBP
-23	54	32	32	440,3	1504	379,0	1,52	5,18	1,30	290,4	1,75	4,46	ASHRAE LBP
-10	130	90	90										
-25	55	32	55	326,2	1114	280,7	1,17	4,01	1,01	277,9	1,72	4,06	cecomaf LBP
-13	131	90	131										
-35	40	20	40	244,3	834	210,2	1,20	4,10	1,03	203,3	1,53	2,79	EN12900 LBP
-31	104	68	104										
-7	54	35	46	809,3	2764	696,5	2,04	6,96	1,75	396,9	2,10	9,23	ASHRAE MBP
20	130	95	115										
-10	55	32	55	640,8	2188	551,5	1,69	5,76	1,45	379,7	2,04	8,11	cecomaf MBP
14	131	90	131										
-10	45	20	45	717,6	2451	617,5	2,10	7,18	1,81	341,3	1,92	8,81	EN12900 MBP
14	113	68	113										

Performance tables

R290, 220V/60Hz, CSIR, fan 3m/s, UL, CCC

	pe		Cooling capacity			COP	EER	P1	I	m	
	[°C]	[°F]	[W]	[Btu/h]	[kcal/h]						
[°C / °F]	-35	-31	228,7	781	196,8	1,10	3,77	0,95	207,4	1,54	2,56
cond. pressure	-23	-10	428,2	1462	368,5	1,55	5,31	1,34	275,4	1,71	4,84
pc= 45/113	-15	5	613,6	2096	528,1	1,93	6,58	1,66	318,5	1,84	6,98
return gas temp.	-9	15	763,0	2606	656,6	2,22	7,58	1,91	343,7	1,92	8,73
RGT= 32/90	-4	25	936,6	3199	806,1	2,56	8,76	2,21	365,3	2,00	10,80
liquid temp	0	32	1074,2	3669	924,5	2,84	9,70	2,45	378,0	2,05	12,46
Tliq= 45/113	7,2	45	1368,9	4675	1178,1	3,46	11,81	2,98	395,7	2,13	16,08
[°C / °F]	-35	-31	171,3	585	147,4	0,86	2,94	0,74	198,9	1,52	2,12
cond. pressure	-23	-10	355,5	1214	306,0	1,22	4,18	1,05	290,4	1,75	4,43
pc= 55/131	-15	5	522,0	1783	449,2	1,50	5,11	1,29	348,6	1,93	6,56
return gas temp	-9	15	655,0	2237	563,7	1,71	5,84	1,47	383,0	2,05	8,29
RGT= 32/90	-4	25	809,3	2764	696,5	1,96	6,69	1,69	413,3	2,16	10,33
liquid temp	0	32	931,6	3182	801,8	2,16	7,37	1,86	431,7	2,23	11,97
Tliq= 55/131	7,2	45	1194,1	4078	1027,7	2,60	8,88	2,24	459,2	2,35	15,56

Model

Designation	NLE8.0CNT	208-230V/60Hz	Conf. 2	Sales code:	105H6073
-------------	------------------	----------------------	----------------	-------------	-----------------

Configuration

Motorconfiguration	eRSCR	
Power supply (nominal)	208-230V/60Hz 1~	
Refrigerant	R290	
Application	LBP+MBP	
Voltage range	187-253V	
Starting torque	LST	
Approvals	UL	SA3693
	CCC	

Electrical accessories / wiring diagram

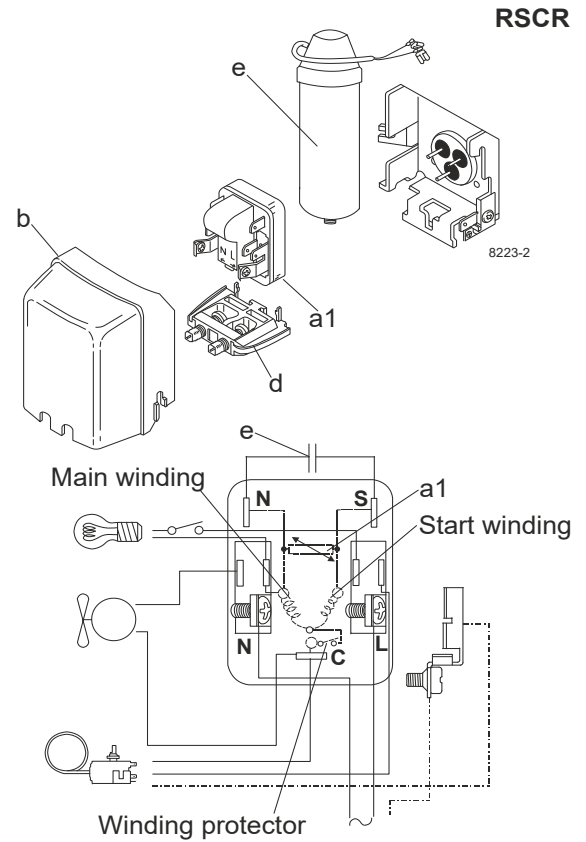

Ambient/ machine room temperatures minimum /maximum

Ambient temperature range:	10 - 43°C / 50 - 110°F
Machine room temperature range:	10 - 48°C / 50 - 119°F
Compressor cooling:	fan 3m/s

Operation pressure range

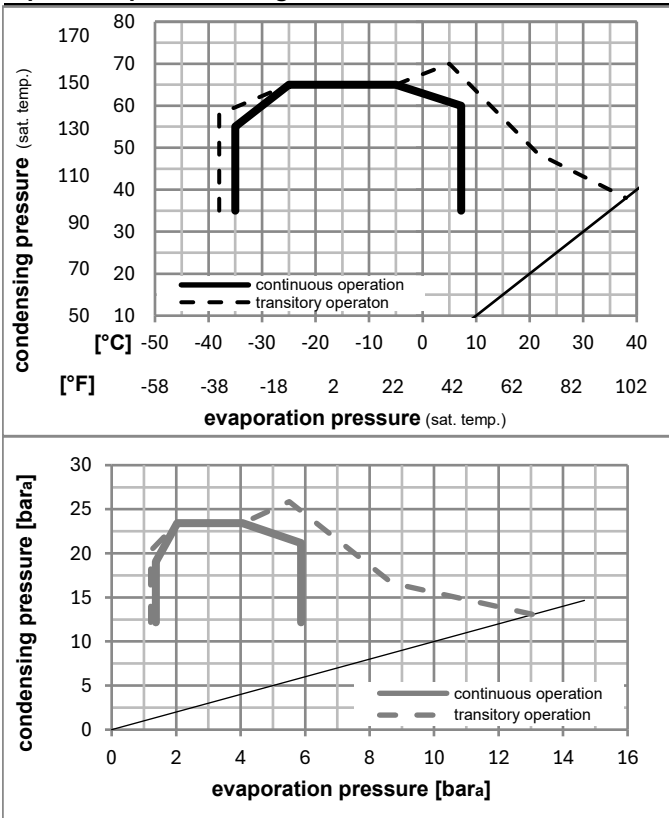

Components

a1	e-PTC starter (220V, 250hm, 4.8mm)	103N0050
e	run capacitor (4μF, 4.8mm)	117-7119
b	plastic cover	103N2011
d	cord relief	103N1010
	bracket for run capacitor	117-0300
	screw M4x8mm	117-0301

Model

Designation **NLE8.0CNT** **208-230V/60Hz** Conf. 2 Sales code: **105H6073**

Optimization + standard conditions

R290, 220V/60Hz, eRSCR, fan 3m/s, UL, CCC

	Evaporating pressure (saturation temperature)				Cooling capacity			COP	EER			Power consumption			ASHRAE LBP
	pe	pc	RGT	Tliq	[W]	[Btu/h]	[kcal/h]		[W/W]	[Btu/Wh]	[kcal/Wh]	P1	I	m	
	[°C]	[°C]	[°C]	[°C]							[W]	[A]	[kg/h]		
	-23	54	32	32	441,5	1508	380,0	1,63	5,57	1,40	270,9	1,33	4,47		
	[°F]														
	-10	130	90	90											
	[°C]	-25	55	32	55	327,0	1117	281,5	1,26	4,31	1,09	259,3	1,28	4,07	cecomaf LBP
	[°F]	-13	131	90	131										
	[°C]	-35	40	20	40	244,7	836	210,6	1,29	4,41	1,11	189,4	1,00	2,80	EN12900 LBP
	[°F]	-31	104	68	104										
	[°C]	-7	54	35	46	812,9	2776	699,6	2,20	7,53	1,90	368,9	1,73	9,27	ASHRAE MBP
	[°F]	20	130	95	115										
	[°C]	-10	55	32	55	643,4	2197	553,8	1,82	6,22	1,57	353,1	1,67	8,14	cecomaf MBP
	[°F]	14	131	90	131										
	[°C]	-10	45	20	45	720,0	2459	619,7	2,26	7,73	1,95	318,0	1,49	8,84	EN12900 MBP
	[°F]	14	113	68	113										

Performance tables

R290, 220V/60Hz, eRSCR, fan 3m/s, UL, CCC

	pe		Cooling capacity			COP	EER		P1	I	m
	[°C]	[°F]	[W]	[Btu/h]	[kcal/h]		[W/W]	[Btu/Wh]			
[°C / °F]	-35	-31	229,1	783	197,2	1,19	4,05	1,02	193,2	1,02	2,57
cond. pressure	-23	-10	429,2	1466	369,4	1,67	5,70	1,44	257,0	1,27	4,85
pc= 45/113	-15	5	615,5	2102	529,7	2,07	7,08	1,78	297,0	1,42	7,00
return gas temp.	-9	15	765,7	2615	658,9	2,39	8,17	2,06	320,2	1,50	8,77
RGT= 32/90	-4	25	940,2	3211	809,1	2,76	9,44	2,38	340,1	1,57	10,84
liquid temp	0	32	1078,5	3683	928,2	3,07	10,47	2,64	351,7	1,62	12,51
Tliq= 45/113	7,2	45	1374,7	4695	1183,1	3,74	12,76	3,22	367,9	1,67	16,15
[°C / °F]	-35	-31	171,8	587	147,8	0,93	3,16	0,80	185,7	0,97	2,12
cond. pressure	-23	-10	356,5	1217	306,8	1,32	4,49	1,13	270,8	1,33	4,44
pc= 55/131	-15	5	523,8	1789	450,8	1,61	5,51	1,39	324,5	1,55	6,59
return gas temp	-9	15	657,7	2246	566,1	1,85	6,31	1,59	356,1	1,68	8,33
RGT= 32/90	-4	25	813,1	2777	699,8	2,12	7,24	1,82	383,8	1,79	10,38
liquid temp	0	32	936,3	3197	805,8	2,34	7,98	2,01	400,5	1,86	12,03
Tliq= 55/131	7,2	45	1200,5	4100	1033,1	2,82	9,64	2,43	425,4	1,95	15,64

Model

Designation	NLE8.0CNT	208-230V/60Hz	Conf. 3	Sales code:	105H6073
-------------	------------------	----------------------	----------------	-------------	-----------------

Configuration

Motorconfiguration	eRSIR	
Power supply (nominal)	208-230V/60Hz 1~	
Refrigerant	R290	
Application	LBP+MBP	
Voltage range	187-253V	
Starting torque	LST	
Approvals	UL	SA3693
	CCC	

Electrical accessories / wiring diagram

RSIR

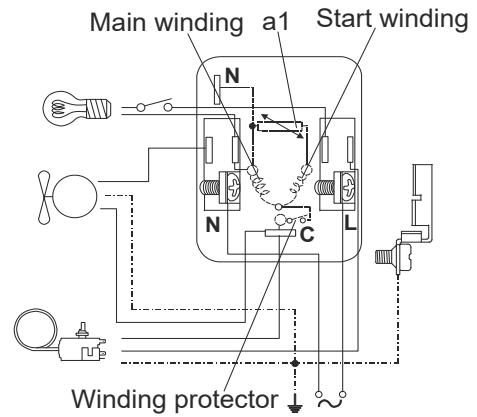
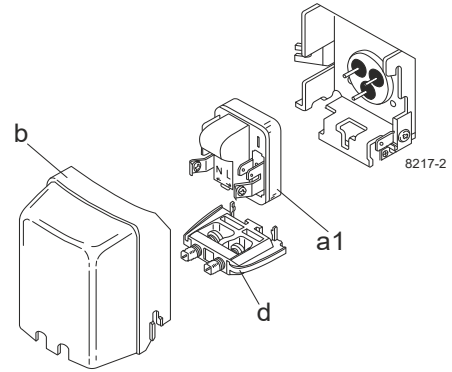

Ambient/ machine room temperatures minimum /maximum

Ambient temperature range:	10 - 43°C / 50 - 110°F
Machine room temperature range:	10 - 48°C / 50 - 119°F
Compressor cooling:	fan 3m/s

Operation pressure range

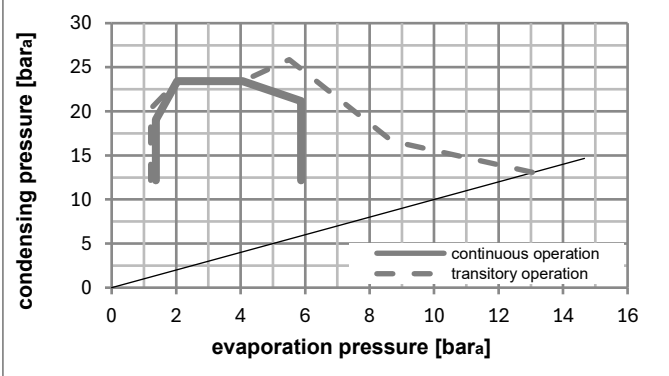
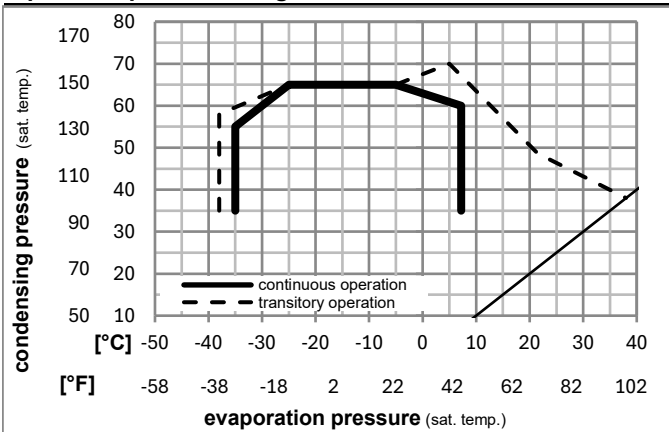

Components

a1	e-PTC starter (220V, 250hm, 4.8mm)	103N0050
b	plastic cover	103N2011
d	cord relief	103N1010

Model

Designation **NLE8.0CNT** **208-230V/60Hz** Conf. 3 Sales code: **105H6073**

Optimization + standard conditions

R290, 220V/60Hz, eRSIR, fan 3m/s, UL, CCC

	Evaporating pressure (saturation temperature)				Cooling capacity			COP	EER			Power consumption			ASHRAE LBP
	pe	pc	RGT	Tliq	[W]	[Btu/h]	[kcal/h]		[W/W]	[Btu/Wh]	[kcal/Wh]	P1	I	m	
[°C]	-23	54	32	32	440,3	1504	379,0	1,52	5,18	1,30	290,4	1,75	4,46		
[°F]	-10	130	90	90											
[°C]	-25	55	32	55	326,2	1114	280,7	1,17	4,01	1,01	277,9	1,72	4,06	cecomaf LBP	
[°F]	-13	131	90	131											
[°C]	-35	40	20	40	244,3	834	210,2	1,20	4,10	1,03	203,3	1,53	2,79	EN12900 LBP	
[°F]	-31	104	68	104											
[°C]	-7	54	35	46	809,3	2764	696,5	2,04	6,96	1,75	396,9	2,10	9,23	ASHRAE MBP	
[°F]	20	130	95	115											
[°C]	-10	55	32	55	640,8	2188	551,5	1,69	5,76	1,45	379,7	2,04	8,11	cecomaf MBP	
[°F]	14	131	90	131											
[°C]	-10	45	20	45	717,6	2451	617,5	2,10	7,18	1,81	341,3	1,92	8,81	EN12900 MBP	
[°F]	14	113	68	113											

Performance tables

R290, 220V/60Hz, eRSIR, fan 3m/s, UL, CCC

	pe		Cooling capacity			COP	EER		P1	I	m
	[°C]	[°F]	[W]	[Btu/h]	[kcal/h]		[W/W]	[Btu/Wh]			
[°C / °F]	-35	-31	228,7	781	196,8	1,10	3,77	0,95	207,4	1,54	2,56
cond. pressure	-23	-10	428,2	1462	368,5	1,55	5,31	1,34	275,4	1,71	4,84
pc= 45/113	-15	5	613,6	2096	528,1	1,93	6,58	1,66	318,5	1,84	6,98
return gas temp.	-9	15	763,0	2606	656,6	2,22	7,58	1,91	343,7	1,92	8,73
RGT= 32/90	-4	25	936,6	3199	806,1	2,56	8,76	2,21	365,3	2,00	10,80
liquid temp	0	32	1074,2	3669	924,5	2,84	9,70	2,45	378,0	2,05	12,46
Tliq= 45/113	7,2	45	1368,9	4675	1178,1	3,46	11,81	2,98	395,7	2,13	16,08
[°C / °F]	-35	-31	171,3	585	147,4	0,86	2,94	0,74	198,9	1,52	2,12
cond. pressure	-23	-10	355,5	1214	306,0	1,22	4,18	1,05	290,4	1,75	4,43
pc= 55/131	-15	5	522,0	1783	449,2	1,50	5,11	1,29	348,6	1,93	6,56
return gas temp	-9	15	655,0	2237	563,7	1,71	5,84	1,47	383,0	2,05	8,29
RGT= 32/90	-4	25	809,3	2764	696,5	1,96	6,69	1,69	413,3	2,16	10,33
liquid temp	0	32	931,6	3182	801,8	2,16	7,37	1,86	431,7	2,23	11,97
Tliq= 55/131	7,2	45	1194,1	4078	1027,7	2,60	8,88	2,24	459,2	2,35	15,56

Model

Designation	NLE8.0CNT	220-230V/50Hz	Conf. 4	Sales code:	105H6073
-------------	------------------	----------------------	----------------	-------------	-----------------

Configuration

Motorconfiguration	CSIR	
Power supply (nominal)	220-230V/50Hz 1~	
Refrigerant	R290	
Application	LBP+MBP	
Voltage range	187-242V	
Starting torque	HST	
Approvals	UL	SA3693
	CCC	

Electrical accessories / wiring diagram

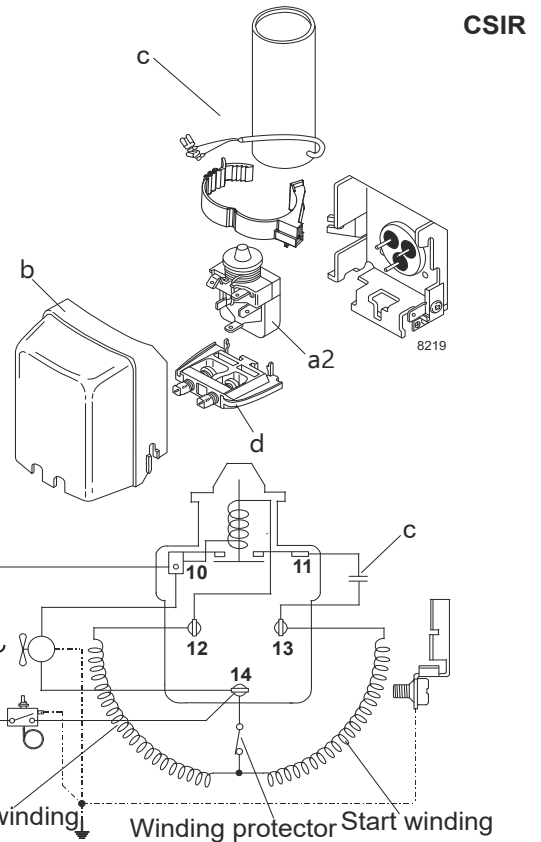

Ambient/ machine room temperatures minimum /maximum

Ambient temperature range:	10 - 43°C / 50 - 110°F
Machine room temperature range:	10 - 48°C / 50 - 119°F
Compressor cooling:	fan 3m/s

Operation pressure range

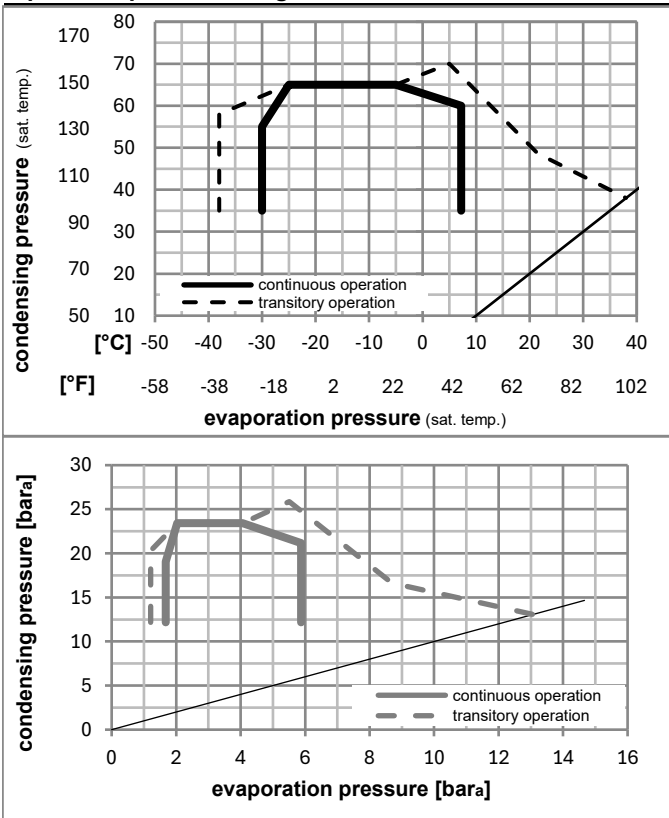

Components

a2	relay	117U7003
c	start capacitor (60μF)	117U5014
b	plastic cover	103N2011
d	cord relief	103N1010

Alternative components

b	plastic cover	103N2010
---	---------------	----------

Model

Designation **NLE8.0CNT** **220-230V/50Hz** Conf. 4 Sales code: **105H6073**

Optimization + standard conditions

R290, 220V/50Hz, CSIR, fan 3m/s, UL, CCC

	Evaporating pressure (saturation temperature)				Cooling capacity			COP	EER	P1	Power consumption		ASHRAE LBP	
	pe	pc	RGT	Tliq	[W]	[Btu/h]	[kcal/h]				I	m		
	[°C]	[°F]	[°C]	[°F]	[W]	[Btu/h]	[kcal/h]	[W/W]	[Btu/Wh]	[kcal/Wh]	[W]	[A]	[kg/h]	
	-23	54	32	32	376,3	1285	323,8	1,45	4,94	1,25	260,0	1,99	3,81	ASHRAE LBP
	-10	130	90	90										
	-25	55	32	55	278,7	952	239,8	1,11	3,80	0,96	250,2	1,96	3,47	cecomaf LBP
	-13	131	90	131										
	-35	40	20	40	208,5	712	179,5	1,09	3,74	0,94	190,5	1,81	2,38	EN12900 LBP
	-31	104	68	104										
	-7	54	35	46	692,8	2366	596,2	2,02	6,89	1,74	343,6	2,20	7,90	ASHRAE MBP
	20	130	95	115										
	-10	55	32	55	548,4	1873	471,9	1,66	5,67	1,43	330,2	2,16	6,94	cecomaf MBP
	14	131	90	131										
	-10	45	20	45	613,6	2096	528,1	2,04	6,98	1,76	300,1	2,05	7,53	EN12900 MBP
	14	113	68	113										

Performance tables

R290, 220V/50Hz, CSIR, fan 3m/s, UL, CCC

	pe		Cooling capacity			COP	EER	P1	I	m	
	[°C]	[°F]	[W]	[Btu/h]	[kcal/h]						
[°C / °F]	-30	-22	262,2	896	225,7	1,20	4,11	1,04	217,9	1,87	2,95
cond. pressure	-23	-10	365,8	1249	314,8	1,47	5,03	1,27	248,1	1,93	4,13
pc= 45/113	-15	5	524,5	1791	451,4	1,86	6,35	1,60	282,2	2,01	5,97
return gas temp.	-9	15	652,5	2228	561,5	2,16	7,38	1,86	302,0	2,06	7,47
RGT= 32/90	-4	25	801,2	2736	689,5	2,51	8,58	2,16	318,9	2,10	9,24
liquid temp	0	32	919,1	3139	791,0	2,80	9,55	2,41	328,8	2,13	10,66
Tliq= 45/113	7,2	45	1171,5	4001	1008,2	3,42	11,68	2,94	342,6	2,17	13,76
[°C / °F]	-30	-22	209,1	714	179,9	0,95	3,25	0,82	219,5	1,90	2,59
cond. pressure	-23	-10	303,8	1037	261,4	1,17	3,99	1,01	260,0	1,99	3,79
pc= 55/131	-15	5	446,4	1525	384,2	1,46	4,99	1,26	305,8	2,10	5,61
return gas temp	-9	15	560,5	1914	482,4	1,68	5,75	1,45	332,7	2,17	7,10
RGT= 32/90	-4	25	693,0	2367	596,4	1,94	6,64	1,67	356,3	2,24	8,84
liquid temp	0	32	797,9	2725	686,7	2,15	7,35	1,85	370,7	2,28	10,25
Tliq= 55/131	7,2	45	1023,2	3494	880,5	2,61	8,92	2,25	391,9	2,35	13,33

Model

Designation	NLE8.0CNT	220-230V/50Hz	Conf. 5	Sales code:	105H6073
-------------	------------------	----------------------	----------------	-------------	-----------------

Configuration

Motor configuration	eRSCR	
Power supply (nominal)	220-230V/50Hz 1~	
Refrigerant	R290	
Application	LBP+MBP	
Voltage range	187-242V	
Starting torque	LST	
Approvals	UL	SA3693
	CCC	

Electrical accessories / wiring diagram

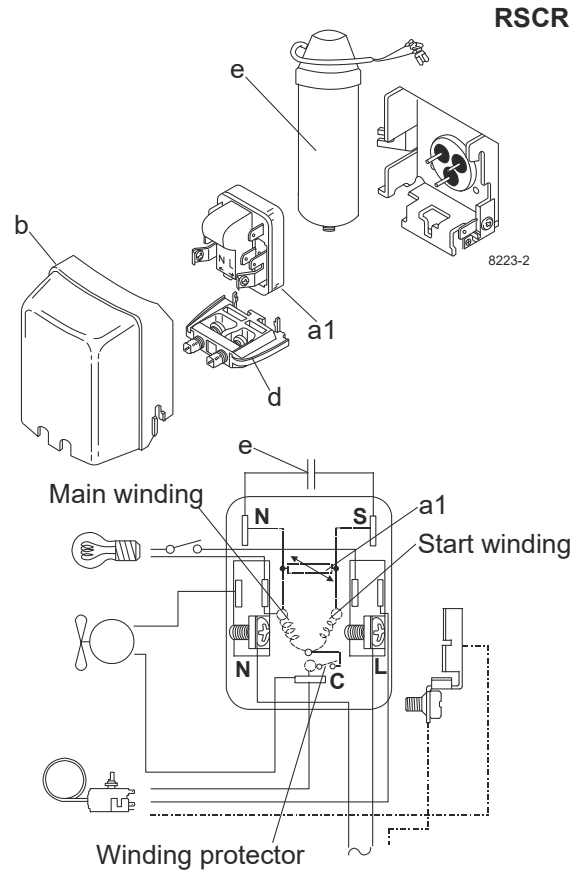

Ambient/ machine room temperatures minimum /maximum

Ambient temperature range:	10 - 43°C / 50 - 110°F
Machine room temperature range:	10 - 48°C / 50 - 119°F
Compressor cooling:	fan 3m/s

Operation pressure range

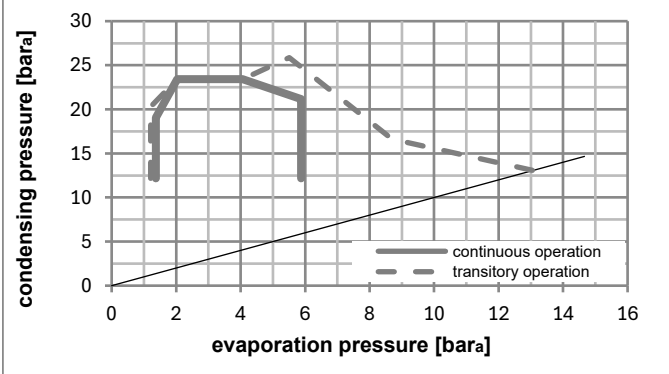
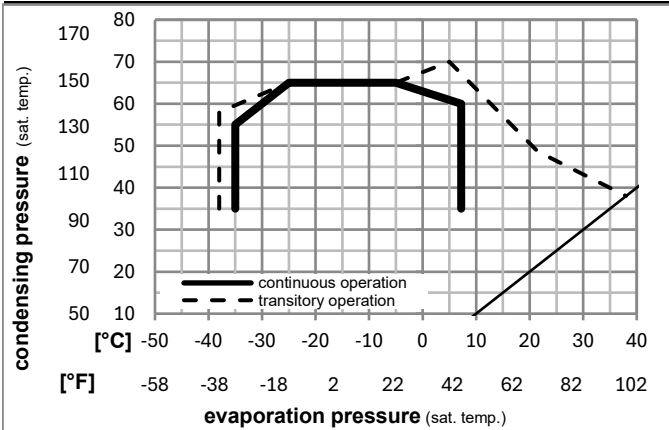

Components

a1	e-PTC starter (220V, 250hm, 4.8mm)	103N0050
e	run capacitor (4μF, 4.8mm)	117-7119
b	plastic cover	103N2011
d	cord relief	103N1010
	bracket for run capacitor	117-0300
	screw M4x8mm	117-0301

Model

Designation **NLE8.0CNT** **220-230V/50Hz** Conf. 5 Sales code: **105H6073**

Optimization + standard conditions

R290, 220V/50Hz, eRSCR, fan 3m/s, UL, CCC

	Evaporating pressure (saturation temperature)				Cooling capacity			COP	EER			Power consumption			ASHRAE LBP
	pe	pc	RGT	Tliq	[W]	[Btu/h]	[kcal/h]		[W/W]	[Btu/Wh]	[kcal/Wh]	P1	I	m	
[°C]	-23	54	32	32	376,9	1287	324,3	1,55	5,30	1,34	242,7	1,56	3,82		
[°F]	-10	130	90	90											
[°C]	-25	55	32	55	279,1	953	240,2	1,20	4,08	1,03	233,4	1,53	3,48	cecomaf LBP	
[°F]	-13	131	90	131											
[°C]	-35	40	20	40	208,7	713	179,6	1,18	4,02	1,01	177,2	1,37	2,38	EN12900 LBP	
[°F]	-31	104	68	104											
[°C]	-7	54	35	46	694,5	2372	597,7	2,16	7,38	1,86	321,6	1,81	7,92	ASHRAE MBP	
[°F]	20	130	95	115											
[°C]	-10	55	32	55	549,6	1877	473,0	1,78	6,08	1,53	308,9	1,77	6,95	cecomaf MBP	
[°F]	14	131	90	131											
[°C]	-10	45	20	45	614,8	2100	529,1	2,19	7,47	1,88	280,9	1,64	7,55	EN12900 MBP	
[°F]	14	113	68	113											

Performance tables

R290, 220V/50Hz, eRSCR, fan 3m/s, UL, CCC

	pe		Cooling capacity			COP	EER			P1	I	m
	[°C]	[°F]	[W]	[Btu/h]	[kcal/h]		[W/W]	[Btu/Wh]	[kcal/Wh]			
[°C / °F]	-35	-31	195,5	668	168,3	1,08	3,70	0,93	180,3	1,39	2,19	
cond. pressure	-23	-10	366,3	1251	315,2	1,58	5,40	1,36	231,7	1,50	4,14	
pc= 45/113	-15	5	525,4	1794	452,2	1,99	6,80	1,71	264,0	1,58	5,98	
return gas temp.	-9	15	653,8	2233	562,6	2,31	7,90	1,99	282,7	1,64	7,48	
RGT= 32/90	-4	25	802,9	2742	691,0	2,69	9,18	2,31	298,8	1,70	9,26	
liquid temp	0	32	921,2	3146	792,8	2,99	10,21	2,57	308,2	1,73	10,68	
Tliq= 45/113	7,2	45	1174,3	4010	1010,6	3,66	12,48	3,15	321,2	1,77	13,80	
[°C / °F]	-35	-31	146,6	501	126,2	0,84	2,88	0,72	174,2	1,38	1,81	
cond. pressure	-23	-10	304,3	1039	261,8	1,25	4,28	1,08	242,7	1,55	3,79	
pc= 55/131	-15	5	447,4	1528	385,0	1,56	5,34	1,35	285,9	1,69	5,62	
return gas temp	-9	15	561,9	1919	483,6	1,81	6,16	1,55	311,3	1,78	7,11	
RGT= 32/90	-4	25	694,8	2373	597,9	2,08	7,11	1,79	333,5	1,85	8,87	
liquid temp	0	32	800,2	2733	688,6	2,31	7,88	1,98	347,0	1,90	10,28	
Tliq= 55/131	7,2	45	1026,2	3505	883,2	2,80	9,55	2,41	366,9	1,97	13,37	



NL Compressors





Service/Repair – R600a, R290

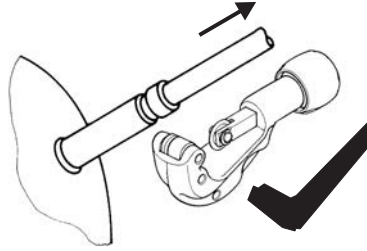

8545

Brazing on Suction Connectors (Direct Intake)

representative image

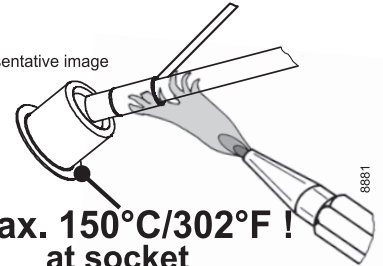

**! max. 150°C/302°F !
at socket**
brazing solder: phosphor (LP7) or silver

Refer to Product Bulletin:
**Brazing on Suction Connectors
(Compressors with Direct Suction Intake)**

Secop accepts no responsibility for possible errors in catalogs, brochures, and other printed material. Secop reserves the right to alter its products without notice. This also applies to products already on order provided that such alterations can be made without subsequential changes being necessary to specifications already agreed. All trademarks in this material are the property of the respective companies. Secop and the Secop logotype are trademarks of Secop GmbH. All rights reserved. www.secop.com