

Single Pack NL8.4MF 220-240V 50Hz / 208-230V 60Hz CSIR

Codice Imballo Singolo: **195B4347**

Posizione	Titolo	Codice	Quantità
1	Compressor NL8.4MF	105G7802	1
2	Starting relay	117U6016	1
3	Starting capacitor (80 μ F 220V, 6.3mm)	117U5015	1
4	Cord relief	103N1010	1
5	Cover	103N2011	1
6	Bolt joint for one compressor M6 \varnothing 16mm	118-1917	1

Secop GmbH • Lise-Meitner-Straße 29 • 24941 Flensburg, Germany • Tel: +49 46149410 • www.secop.com

Secop non si assume alcuna responsabilità per eventuali errori presenti in cataloghi, brochure e altro materiale stampato. Secop si riserva il diritto di modificare i propri prodotti senza preavviso. Ciò vale anche per i prodotti già ordinati, a condizione che tali modifiche possano essere apportate senza che siano necessarie modifiche successive alle specifiche già concordate. Tutti i marchi presenti in questo materiale sono di proprietà delle rispettive aziende. Secop e il logo Secop sono marchi di Secop GmbH. Tutti i diritti sono riservati.

Model

Designation	NL8.4MF	220-240V/50Hz 1~ 208-230V/60Hz 1~	Sales code:	105G7802
-------------	----------------	--	-------------	-----------------

Compressor design

Oil type	Polyolester	Refrigerant(s)	R134a, R513A
Oil viscosity	32cST	Displacement	8,35cm ³ / 0,51cu.in
Oil quantity	268cm ³ / 9,1fl.oz	Compressors on pallet	80
Refr. charge - tech. limit	600g / 21,2oz		
Free gas volume comp.	2360cm ³ / 79,8fl.oz		
Weight	10,5kg / 23,1lbs		
Motor protection	1# internal		
Winding resistance main	7,1Ω (at 25°C)		
Winding resistance aux	9,6Ω (at 25°C)		
Max. winding temp.	125°C / 257°F		
Max. discharge temp.	130°C / 266°F		



General - Configurations with NL8.4MF

	Conf. 1	Conf. 2	Conf. 3	Conf. 4	Conf. 5
Motorconfiguration	RSIR	CSIR	CSIR	CSIR	CSIR
Power supply (nominal)	220-240V/50Hz	220-240V/50Hz	208-230V/60Hz	220-240V/50Hz	208-230V/60Hz
Number of phases	1	1	1	1	1
Voltage range	187-254V	187-254V	187-254V	187-254V	187-253V
Approvals	VDE, CCC, EAC, UL	VDE, CCC, EAC, UL	CCC, EAC, UL	VDE, CCC, UL	CCC, UL
Starting torque	LST	HST	HST	HST	HST
Note	No RSIR for 60Hz operation.				

Applications with NL8.4MF

	Conf. 1	Conf. 2	Conf. 3	Conf. 4	Conf. 5
Refrigerant	R134a	R134a	R134a	R513A	R513A
Application	MBP+HBP	MBP+HBP	LBP+MBP	MBP+HBP	LBP+MBP
System cooling	fan 1,5m/s	fan 1,5m/s	fan 1,5m/s	fan 1,5m/s	fan 1,5m/s
Hot gas defrost	-/-	-/-	-/-	-/-	-/-
Long interval pull down	OK	OK	OK	OK	OK

Electrical data - Configurations with NL8.4MF

	Conf. 1	Conf. 2	Conf. 3	Conf. 4	Conf. 5
Starting device type	PTC	relay	relay	relay	relay
Run capacitor	-/-	-/-	-/-	-/-	-/-
Start capacitor	-/-	80μF	80μF	80μF	80μF
LRA (locked rotor amps / 4s)	10,8A	10,6A	10,3A	10,6A	10,3A
RLA (rated load amps / 1s)	2,2A	2,2A	1,9A	2,2A	1,9A
Cut in current	16,3A	10,6A	10,3A	10,6A	10,3A

Model

Designation	NL8.4MF	220-240V/50Hz 1~ 208-230V/60Hz 1~	Sales code:	105G7802
-------------	----------------	--	-------------	-----------------

Compressor dimensions

Housing	A Height	197mm / 7,76in
	B Height	191mm / 7,52in
	C Length shell	205mm / 8,07in
	D Length w. cover	254mm / 10in
	E Width	166mm / 6,54in

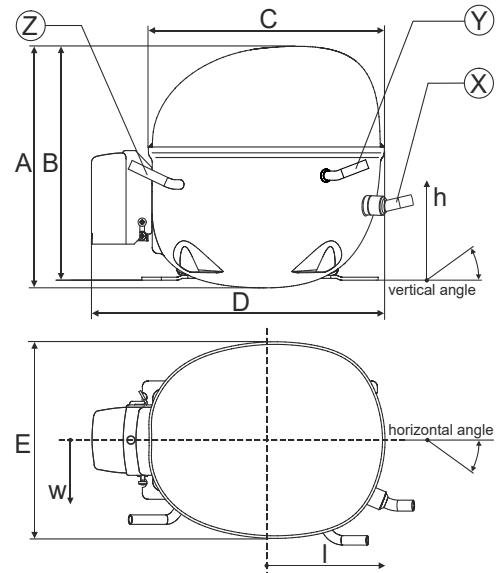

Connectors		Suction	Discharge	Process
		X	Y	Z
Diameter	[mm]	øi 8,11-8,29	øi 6,11-6,29	øi 6,11-6,29
	(i:inside, o:outside) [in]	øi 0,32-0,33	øi 0,24-0,25	øi 0,24-0,25
Material		copper	copper	copper
Horizontal angle	±2°	0°	0°	0°
Vertical angle	±2°	15°	35°	155°
Position l/h/w	[mm]	126/76/78	133/103/54	-107/94/72
	[in]	4,9/3/3,1	5,2/4/2,1	-4,2/3,7/2,8
Straight tube l.	[mm]	12	12	12
	[in]	0,5	0,5	0,5

Compressor fixation

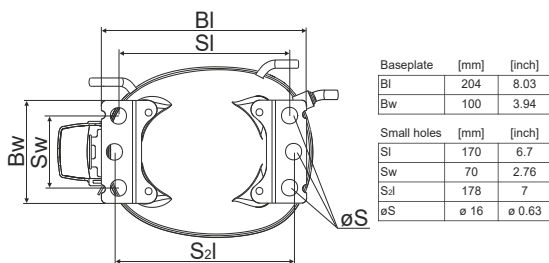

Bolt joint

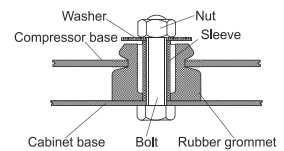

Snap-on

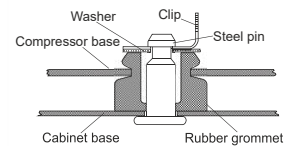

Mounting accessories	one comp.	multi pack
Bolt joint M6 ø16mm	118-1917	118-1918
Bolt joint ø1/4" ø16mm	118-1946	
Bolt joint ø1/4" ø19mm	118-1949	
Snap-on ø7,3 ø16mm	118-1947	118-1919

Model

Designation	NL8.4MF	220-240V/50Hz	Conf. 1	Sales code:	105G7802
-------------	----------------	----------------------	----------------	-------------	-----------------

Configuration

Motorconfiguration	RSIR
Power supply (nominal)	220-240V/50Hz 1~
Refrigerant	R134a
Application	MBP+HBP
Voltage range	187-254V
Starting torque	LST
Approvals	VDE CCC EAC UL

Electrical accessories / wiring diagram

RSIR

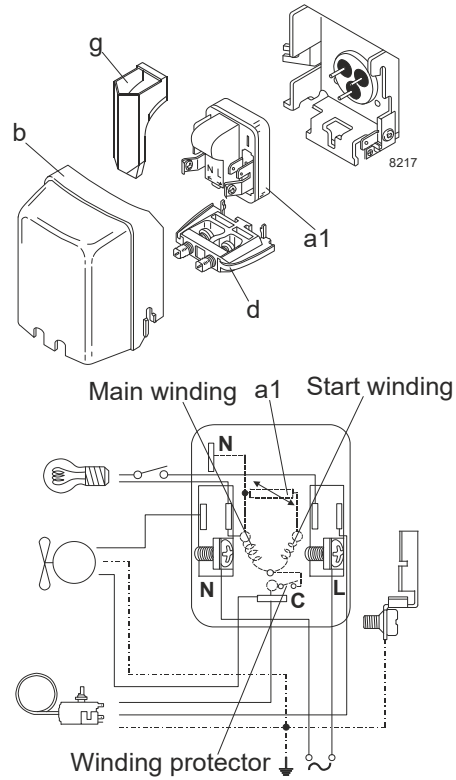

Ambient temperatures / system cooling

Ambient temperature min.:	10°C / 50°F
Ambient temperature max.:	43°C / 110°F

System cooling (n/a: outside limits)			
T ambient	LBP	MBP	HBP
32°C / 90°F	n/a	fan 1,5m/s	fan 1,5m/s
38°C / 100°F	n/a	fan 3m/s	fan 3m/s
43°C / 110°F	n/a	fan 3m/s	fan 3m/s

Operation pressure range

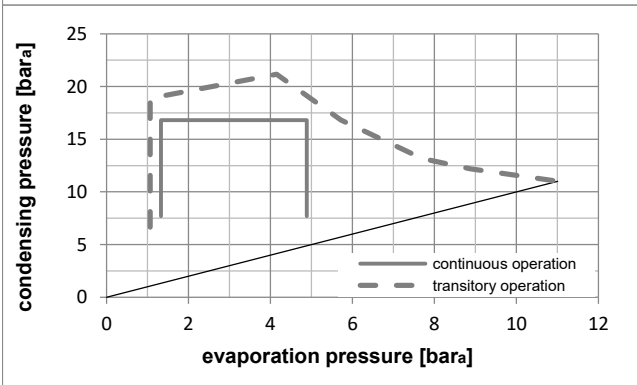
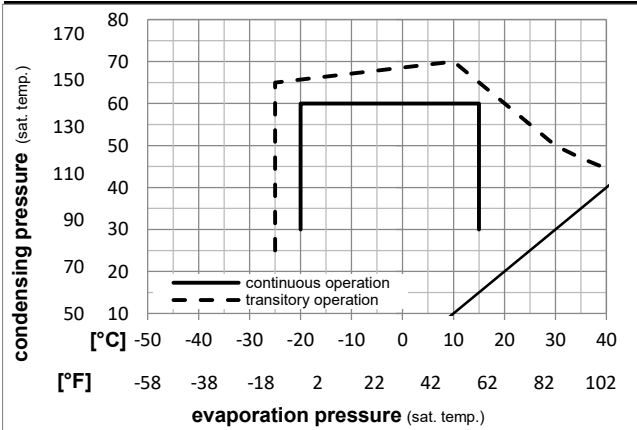

Components

a1	PTC starter (220V, 250hm, 4.8mm)	103N0018
b	plastic cover	103N2011
d	cord relief	103N1010
g	protection screen for PTC	103N0476

Alternative components

a1	PTC starter (220V, 250hm, 6.3mm)	103N0011
b	plastic cover	103N2011
d	cord relief	103N1010
g	protection screen for PTC	103N0476

Model

Designation **NL8.4MF 220-240V/50Hz** Conf. 1 Sales code: **105G7802**

Optimization + standard conditions

R134a, 220V/50Hz, RSIR, fan 1,5m/s, VDE, CCC, EAC, UL

Evaporating pressure (saturation temperature)					Condensing pressure (saturation temperature)					Power consumption				
					Return gas temp.					Current consumption				
					Liquid temp.					Ref. mass flow				
					Cooling capacity					COP EER				
pe	pc	RGT	Tliq		[W]	[Btu/h]	[kcal/h]	[W/W]	[Btu/Wh]	[kcal/Wh]	P1	I	m	
[°C]	[°C]		[°C]	[°C]							[W]	[A]	[kg/h]	
[°C]	7,22	54,4	35	46,1	822,7	2810	708,0	2,27	7,76	1,95	362,2	2,27	18,25	ASHRAE HBP
[°F]	45	130	95	115										HBP
[°C]	5	55	32	55	678,8	2318	584,2	1,94	6,64	1,67	349,2	2,20	16,73	cecomaf HBP
[°F]	41	131	89,6	131										HBP
[°C]	5	50	20	50	702,4	2399	604,5	2,09	7,12	1,79	336,7	2,16	17,70	EN12900 HBP
[°F]	41	122	68	122										HBP
[°C]	-6,66	54,4	35	46,1	457,0	1561	393,3	1,64	5,61	1,41	278,3	1,96	9,97	ASHRAE MBP
[°F]	20	130	95	115										MBP
[°C]	-10	55	32	55	353,4	1207	304,1	1,36	4,63	1,17	260,8	1,92	8,54	cecomaf MBP
[°F]	14	131	89,6	131										MBP
[°C]	-10	45	20	45	399,9	1366	344,1	1,61	5,51	1,39	247,7	1,91	9,36	EN12900 MBP
[°F]	14	113	68	113										MBP

Performance tables

R134a, 220V/50Hz, RSIR, fan 1,5m/s, VDE, CCC, EAC, UL

	pe	Cooling capacity			COP			EER			P1	I	m
	[°C]	[°F]	[W]	[Btu/h]	[kcal/h]	[W/W]	[Btu/Wh]	[kcal/Wh]	[W]	[A]	[kg/h]		
[°C / °F]	-20	-4	251,5	859	216,4	1,24	4,24	1,07	202,5	1,83	5,46		
cond. pressure	-15	5	325,7	1112	280,3	1,45	4,95	1,25	224,8	1,87	7,10		
pc= 45/113	-10	14	414,8	1417	357,0	1,67	5,72	1,44	247,7	1,91	9,08		
return gas temp.	-5	23	520,8	1779	448,2	1,92	6,55	1,65	271,7	1,95	11,45		
RGT= 32/90	0	32	645,5	2205	555,5	2,17	7,42	1,87	297,1	2,02	14,28		
liquid temp	5	41	790,8	2701	680,6	2,44	8,33	2,10	324,3	2,13	17,61		
Tliq= 45/113	15	59	1150,8	3930	990,4	2,99	10,20	2,57	385,2	2,50	26,07		
[°C / °F]	-20	-4	213,0	728	183,3	1,02	3,49	0,88	208,5	1,84	5,11		
cond. pressure	-15	5	276,8	945	238,2	1,18	4,04	1,02	234,2	1,88	6,66		
pc= 55/131	-10	14	353,4	1207	304,1	1,36	4,63	1,17	260,8	1,92	8,54		
return gas temp	-5	23	444,7	1519	382,7	1,54	5,26	1,33	288,6	1,98	10,81		
RGT= 32/90	0	32	552,5	1887	475,5	1,74	5,94	1,50	317,9	2,07	13,51		
liquid temp	5	41	678,8	2318	584,2	1,94	6,64	1,67	349,2	2,20	16,73		
Tliq= 55/131	15	59	994,4	3396	855,8	2,37	8,11	2,04	418,7	2,65	24,98		

Model

Designation	NL8.4MF	220-240V/50Hz	Conf. 2	Sales code:	105G7802
-------------	----------------	----------------------	----------------	-------------	-----------------

Configuration

Motorconfiguration	CSIR
Power supply (nominal)	220-240V/50Hz 1~
Refrigerant	R134a
Application	MBP+HBP
Voltage range	187-254V
Starting torque	HST
Approvals	VDE CCC EAC UL

Electrical accessories / wiring diagram

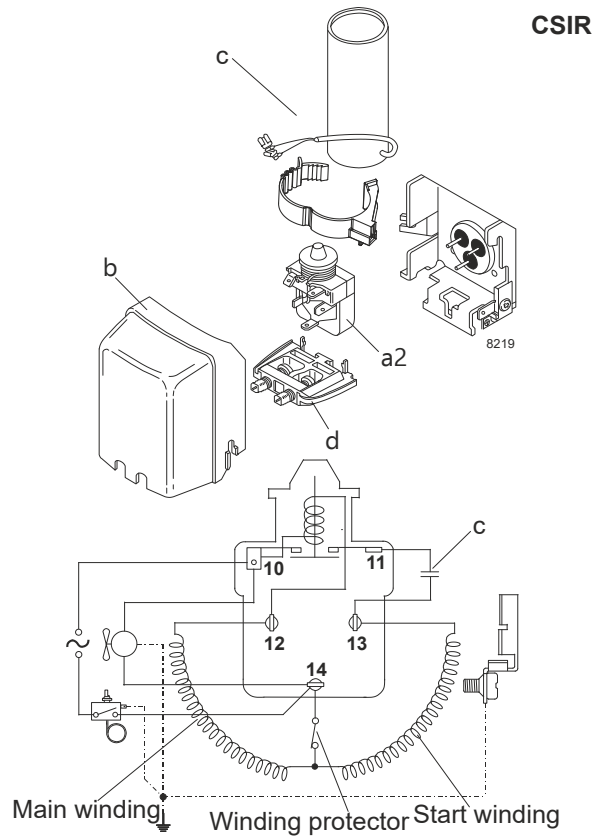

Ambient temperatures / system cooling

Ambient temperature min.:	10°C / 50°F
Ambient temperature max.:	43°C / 110°F

System cooling (n/a: outside limits)			
T ambient	LBP	MBP	HBP
32°C / 90°F	n/a	fan 1,5m/s	fan 1,5m/s
38°C / 100°F	n/a	fan 3m/s	fan 3m/s
43°C / 110°F	n/a	fan 3m/s	fan 3m/s

Operation pressure range

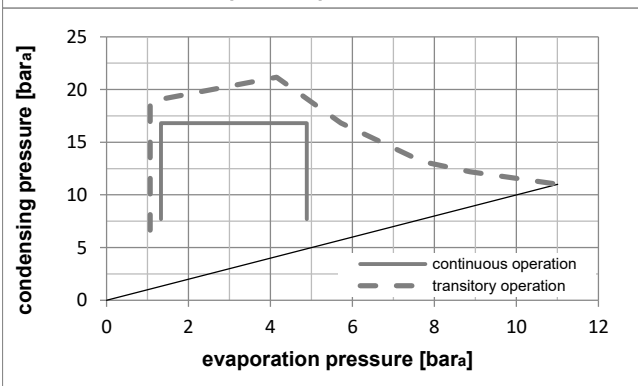
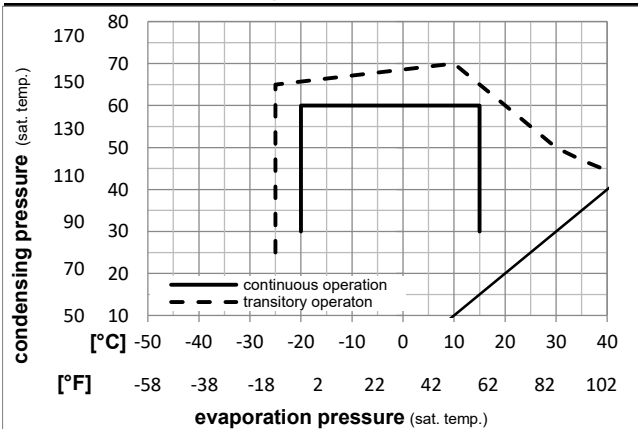

Components

a2	relay	117U6016
c	start capacitor (80µF)	117U5015
b	plastic cover	103N2011
d	cord relief	103N1010

Model

Designation **NL8.4MF 220-240V/50Hz** Conf. 2 Sales code: **105G7802**

Optimization + standard conditions

R134a, 220V/50Hz, CSIR, fan 1,5m/s, VDE, CCC, EAC, UL

Evaporating pressure (saturation temperature)		Condensing pressure (saturation temperature)				Cooling capacity						Power consumption			ASHRAE HBP
		Return gas temp.				COP						Current consumption			
		Liquid temp.				EER						Ref. mass flow			
pe		pc				[W]						P1			[kg/h]
[°C]		[°F]				[Btu/h]						[A]			
[°F]		[°C]				[kcal/h]						[W]			
7,22		54,4				822,7						362,2			18,25
45		130				2810						2,27			
35		46,1				708,0						362,2			18,25
95		115				2,27						2,27			
5		55				678,8						349,2			16,73
41		131				2318						2,20			
32		55				584,2						349,2			16,73
89,6		131				1,94						2,20			
5		50				702,4						336,7			17,70
41		122				2399						2,16			
20		50				604,5						336,7			17,70
68		122				2,09						2,16			
-6,7		54,4				457,0						278,3			9,97
20		130				1561						1,96			
35		46,1				393,3						278,3			9,97
95		115				1,64						1,96			
-10		55				353,4						260,8			8,54
14		131				1207						1,92			
32		55				304,1						260,8			8,54
89,6		131				1,36						1,92			
-10		45				399,9						247,7			9,36
14		113				1366						1,91			
20		45				344,1						247,7			9,36
68		113				1,61						1,91			

Performance tables

R134a, 220V/50Hz, CSIR, fan 1,5m/s, VDE, CCC, EAC, UL

	pe		Cooling capacity			COP			EER		P1	I	m
	[°C]	[°F]	[W]	[Btu/h]	[kcal/h]	[W/W]	[Btu/Wh]	[kcal/Wh]	[W]	[A]	[kg/h]		
[°C / °F]	-20	-4	251,5	859	216,4	1,24	4,24	1,07	202,5	1,83	5,46		
cond. pressure	-15	5	325,7	1112	280,3	1,45	4,95	1,25	224,8	1,87	7,10		
pc= 45/113	-10	14	414,8	1417	357,0	1,67	5,72	1,44	247,7	1,91	9,08		
return gas temp.	-5	23	520,8	1779	448,2	1,92	6,55	1,65	271,7	1,95	11,45		
RGT= 32/90	0	32	645,5	2205	555,5	2,17	7,42	1,87	297,1	2,02	14,28		
liquid temp	5	41	790,8	2701	680,6	2,44	8,33	2,10	324,3	2,13	17,61		
Tliq= 45/113	15	59	1150,8	3930	990,4	2,99	10,20	2,57	385,2	2,50	26,07		
[°C / °F]	-20	-4	213,0	728	183,3	1,02	3,49	0,88	208,5	1,84	5,11		
cond. pressure	-15	5	276,8	945	238,2	1,18	4,04	1,02	234,2	1,88	6,66		
pc= 55/131	-10	14	353,4	1207	304,1	1,36	4,63	1,17	260,8	1,92	8,54		
return gas temp	-5	23	444,7	1519	382,7	1,54	5,26	1,33	288,6	1,98	10,81		
RGT= 32/90	0	32	552,5	1887	475,5	1,74	5,94	1,50	317,9	2,07	13,51		
liquid temp	5	41	678,8	2318	584,2	1,94	6,64	1,67	349,2	2,20	16,73		
Tliq= 55/131	15	59	994,4	3396	855,8	2,37	8,11	2,04	418,7	2,65	24,98		

Model

Designation	NL8.4MF	208-230V/60Hz	Conf. 3	Sales code:	105G7802
-------------	----------------	----------------------	----------------	-------------	-----------------

Configuration

Motorconfiguration	CSIR
Power supply (nominal)	208-230V/60Hz 1~
Refrigerant	R134a
Application	LBP+MBP
Voltage range	187-254V
Starting torque	HST
Approvals	CCC
	EAC
	UL

Electrical accessories / wiring diagram

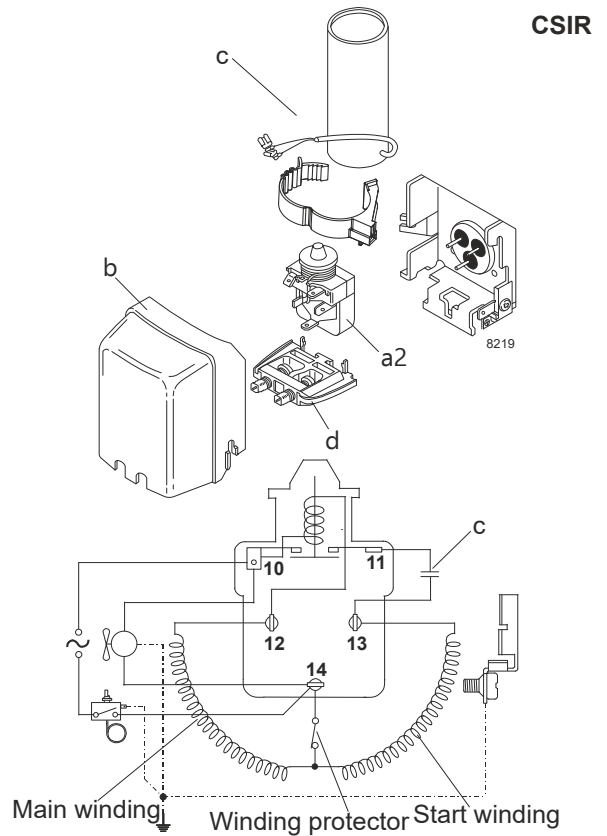

Ambient temperatures / system cooling

Ambient temperature min.:	10°C / 50°F
Ambient temperature max.:	43°C / 110°F

System cooling (n/a: outside limits)			
T ambient	LBP	MBP	HBP
32°C / 90°F	fan 1,5m/s	fan 1,5m/s	n/a
38°C / 100°F	fan 1,5m/s	fan 1,5m/s	n/a
43°C / 110°F	fan 1,5m/s	fan 1,5m/s	n/a

Operation pressure range

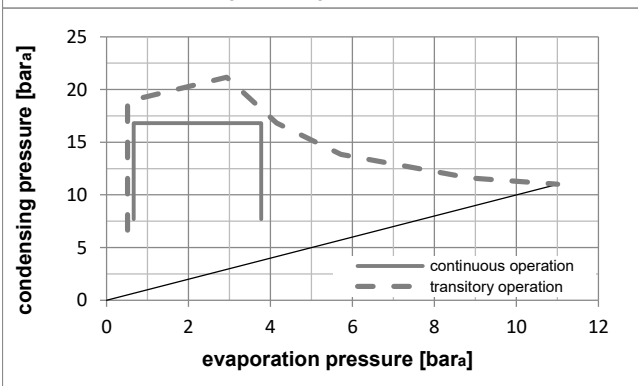
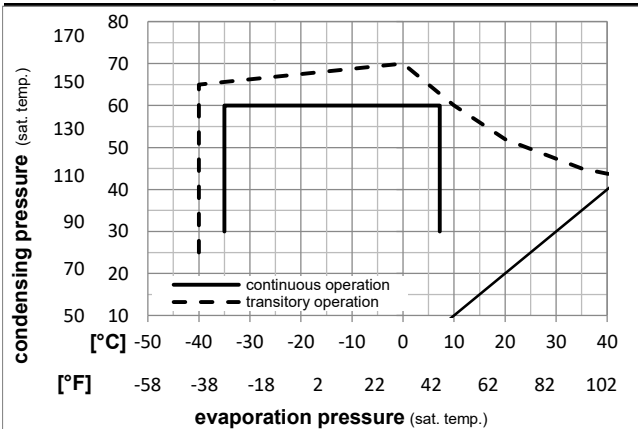

Components

a2	relay	117U6016
c	start capacitor (80µF)	117U5015
b	plastic cover	103N2011
d	cord relief	103N1010

Model

Designation	NL8.4MF	208-230V/60Hz	Conf. 3	Sales code:	105G7802
-------------	----------------	----------------------	----------------	-------------	-----------------

Optimization + standard conditions

R134a, 220V/60Hz, CSIR, fan 1,5m/s, CCC, EAC, UL

Evaporating pressure (saturation temperature)		Condensing pressure (saturation temperature)				Return gas temp.		Liquid temp.		Cooling capacity			COP		EER		Power consumption		Current consumption		Ref. mass flow		
pe	pc	RGT	Tliq							[W]	[Btu/h]	[kcal/h]	[W/W]	[Btu/Wh]	[kcal/Wh]	P1	I			m			
[°C]	[°C]	[°C]	[°C]	[°C]	[W]	[Btu/h]	[kcal/h]	[W/W]	[Btu/Wh]	[kcal/Wh]	[W]	[A]	[kg/h]										
7,22	54,4	35	46,1	993,0	3391	854,6	2,19	7,48	1,89	453,3	2,44	22,03	ASHRAE HBP										
45	130	95	115																				
5	55	32	55	817,9	2793	703,9	1,87	6,39	1,61	437,3	2,37	20,15	cecomaf HBP										
41	131	89,6	131																				
5	50	20	50	852,1	2910	733,3	2,05	7,00	1,76	415,8	2,30	21,47	EN12900 HBP										
41	122	68	122																				
-6,66	54,4	35	46,1	546,8	1867	470,6	1,62	5,53	1,39	337,6	1,96	11,93	ASHRAE MBP										
20	130	95	115																				
-10	55	32	55	419,6	1433	361,1	1,35	4,61	1,16	310,9	1,86	10,15	cecomaf MBP										
14	131	89,6	131																				
-10	45	20	45	483,8	1652	416,4	1,65	5,63	1,42	293,4	1,80	11,33	EN12900 MBP										
14	113	68	113																				

Performance tables

R134a, 220V/60Hz, CSIR, fan 1,5m/s, CCC, EAC, UL

[°C / °F]	pe	Cooling capacity			COP		EER		P1	I	m
	[°C]	[°F]	[W]	[Btu/h]	[kcal/h]	[W/W]	[Btu/Wh]	[kcal/Wh]	[W]	[A]	[kg/h]
-35	-31	114,7	392	98,7	0,91	3,10	0,78	126,2	1,28	2,47	
cond. pressure	-25	-13	227,0	775	195,3	1,19	4,05	1,02	191,2	1,46	4,92
pc= 45/113	-15	5	393,2	1343	338,4	1,52	5,19	1,31	259,0	1,68	8,57
return gas temp.	-10	14	502,0	1714	432,0	1,71	5,84	1,47	293,4	1,80	10,99
RGT= 32/90	-5	23	630,7	2154	542,8	1,92	6,57	1,65	328,0	1,94	13,87
liquid temp	0	32	781,5	2669	672,6	2,16	7,36	1,85	362,6	2,08	17,28
Tliq= 45/113	7,2	45	1041,9	3558	896,7	2,53	8,64	2,18	412,0	2,30	23,27
-35	-31	76,5	261	65,9	0,69	2,37	0,60	110,3	1,22	1,82	
cond. pressure	-25	-13	178,6	610	153,7	0,95	3,24	0,82	188,0	1,45	4,27
pc= 55/131	-15	5	324,7	1109	279,4	1,21	4,12	1,04	269,3	1,72	7,82
return gas temp	-10	14	419,6	1433	361,1	1,35	4,61	1,16	310,9	1,86	10,15
RGT= 32/90	-5	23	532,0	1817	457,9	1,51	5,15	1,30	352,9	2,02	12,93
liquid temp	0	32	664,0	2268	571,5	1,68	5,74	1,45	395,1	2,19	16,24
Tliq= 55/131	7,2	45	893,0	3050	768,5	1,96	6,69	1,69	455,9	2,45	22,09

Model

Designation	NL8.4MF	220-240V/50Hz	Conf. 4	Sales code:	105G7802
-------------	----------------	----------------------	----------------	-------------	-----------------

Configuration

Motorconfiguration	CSIR
Power supply (nominal)	220-240V/50Hz 1~
Refrigerant	R513A
Application	MBP+HBP
Voltage range	187-254V
Starting torque	HST
Approvals	VDE CCC UL

Electrical accessories / wiring diagram

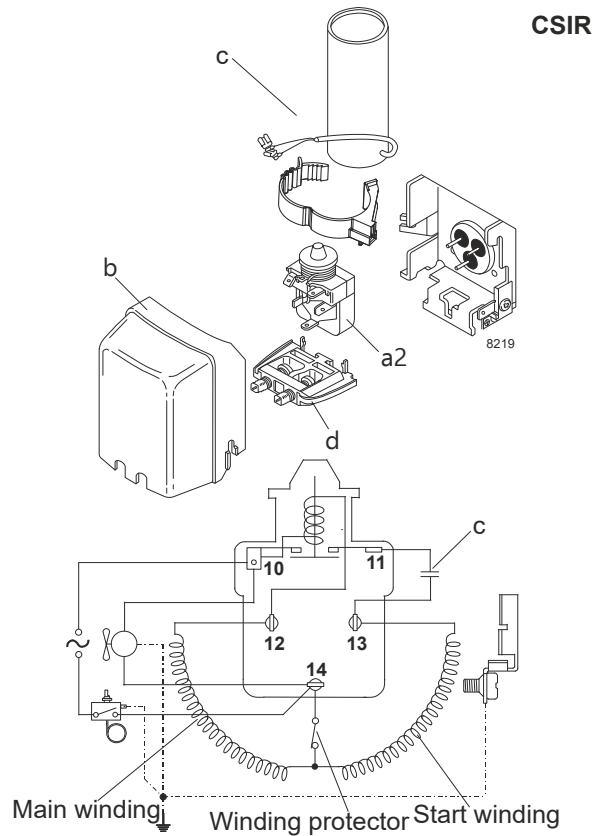

Ambient temperatures / system cooling

Ambient temperature min.:	10°C / 50°F
Ambient temperature max.:	43°C / 110°F

System cooling (n/a: outside limits)			
T ambient	LBP	MBP	HBP
32°C / 90°F	n/a	fan 1,5m/s	fan 1,5m/s
38°C / 100°F	n/a	fan 3m/s	fan 3m/s
43°C / 110°F	n/a	fan 3m/s	fan 3m/s

Operation pressure range

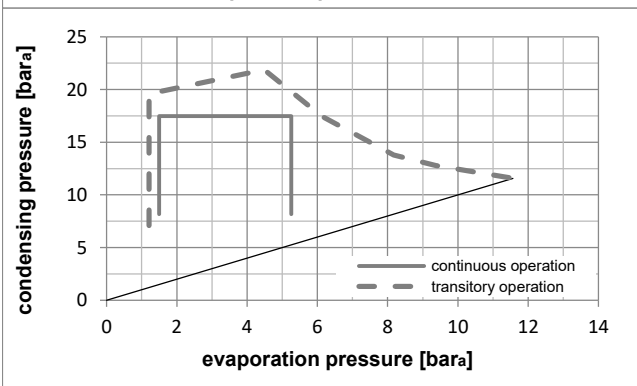
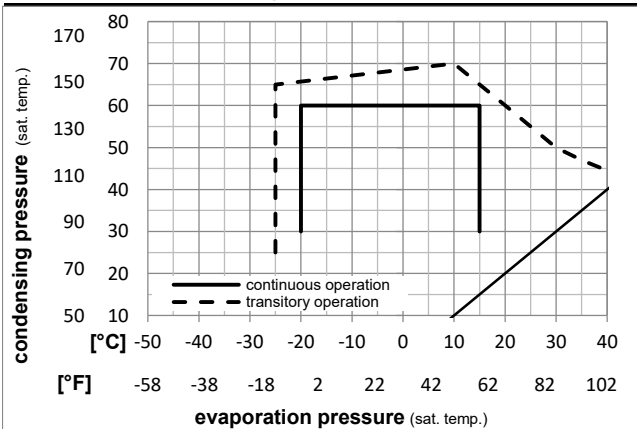

Components

a2	relay	117U6016
c	start capacitor (80µF)	117U5015
b	plastic cover	103N2011
d	cord relief	103N1010

Model

Designation **NL8.4MF 220-240V/50Hz** Conf. 4 Sales code: **105G7802**

Optimization + standard conditions

R513A, 220V/50Hz, CSIR, fan 1,5m/s, VDE, CCC, UL

Evaporating pressure (saturation temperature)		Condensing pressure (saturation temperature)				Power consumption									ASHRAE HBP	
		Return gas temp.				Current consumption										Ref. mass flow m
		Liquid temp.				Cooling capacity	COP	EER	P1	I		m				
pe	pc	RGT	Tliq	[W]	[Btu/h]					[kcal/h]	[W/W]		[Btu/Wh]	[kcal/Wh]		
[°C]	7,22	54,4	35	46,1	846,4	2891	728,4	2,24	7,64	1,93	378,2	2,30	21,03	ASHRAE HBP		
[°F]	45	130	95	115												
[°C]	5	55	32	55	688,2	2350	592,3	1,88	6,44	1,62	365,2	2,27	19,34	cecomaf HBP		
[°F]	41	131	89,6	131												
[°C]	5	50	20	50	713,2	2436	613,8	2,03	6,92	1,74	352,0	2,23	20,45	EN12900 HBP		
[°F]	41	122	68	122												
[°C]	-6,66	54,4	35	46,1	480,5	1641	413,6	1,63	5,58	1,41	294,3	2,07	11,77	ASHRAE MBP		
[°F]	20	130	95	115												
[°C]	-10	55	32	55	367,5	1255	316,3	1,33	4,53	1,14	276,8	2,02	10,16	cecomaf MBP		
[°F]	14	131	89,6	131												
[°C]	-10	45	20	45	418,6	1430	360,2	1,60	5,45	1,37	262,1	1,98	11,09	EN12900 MBP		
[°F]	14	113	68	113												

Performance tables

R513A, 220V/50Hz, CSIR, fan 1,5m/s, VDE, CCC, UL

[°C / °F]	pe	Cooling capacity			COP		EER		P1	I	m
	[°C]	[°F]	[W]	[Btu/h]	[kcal/h]	[W/W]	[Btu/Wh]	[kcal/Wh]	[W]	[A]	[kg/h]
[°C / °F]	-20	-4	271,2	926	233,4	1,25	4,28	1,08	216,5	1,85	6,63
cond. pressure	-15	5	347,1	1185	298,7	1,45	4,96	1,25	239,0	1,91	8,51
pc= 45/113	-10	14	437,7	1495	376,7	1,67	5,70	1,44	262,1	1,98	10,76
return gas temp.	-5	23	544,8	1860	468,8	1,90	6,50	1,64	286,2	2,05	13,45
RGT= 32/90	0	32	670,0	2288	576,6	2,15	7,34	1,85	311,7	2,12	16,62
liquid temp	5	41	815,2	2784	701,6	2,41	8,22	2,07	338,8	2,19	20,33
Tliq= 45/113	15	59	1172,4	4004	1009,0	2,93	10,02	2,52	399,8	2,36	29,66
[°C / °F]	-20	-4	227,2	776	195,6	1,01	3,46	0,87	224,2	1,87	6,24
cond. pressure	-15	5	291,2	994	250,6	1,16	3,98	1,00	250,1	1,94	8,02
pc= 55/131	-10	14	367,5	1255	316,3	1,33	4,53	1,14	276,8	2,02	10,16
return gas temp	-5	23	457,9	1564	394,1	1,50	5,13	1,29	304,6	2,10	12,72
RGT= 32/90	0	32	564,3	1927	485,6	1,69	5,77	1,45	334,0	2,18	15,76
liquid temp	5	41	688,2	2350	592,3	1,88	6,44	1,62	365,2	2,27	19,34
Tliq= 55/131	15	59	996,0	3402	857,2	2,29	7,82	1,97	434,7	2,46	28,45

Model

Designation	NL8.4MF	208-230V/60Hz	Conf. 5	Sales code:	105G7802
-------------	----------------	----------------------	----------------	-------------	-----------------

Configuration

Motorconfiguration	CSIR
Power supply (nominal)	208-230V/60Hz 1~
Refrigerant	R513A
Application	LBP+MBP
Voltage range	187-253V
Starting torque	HST
Approvals	CCC
	UL

Electrical accessories / wiring diagram

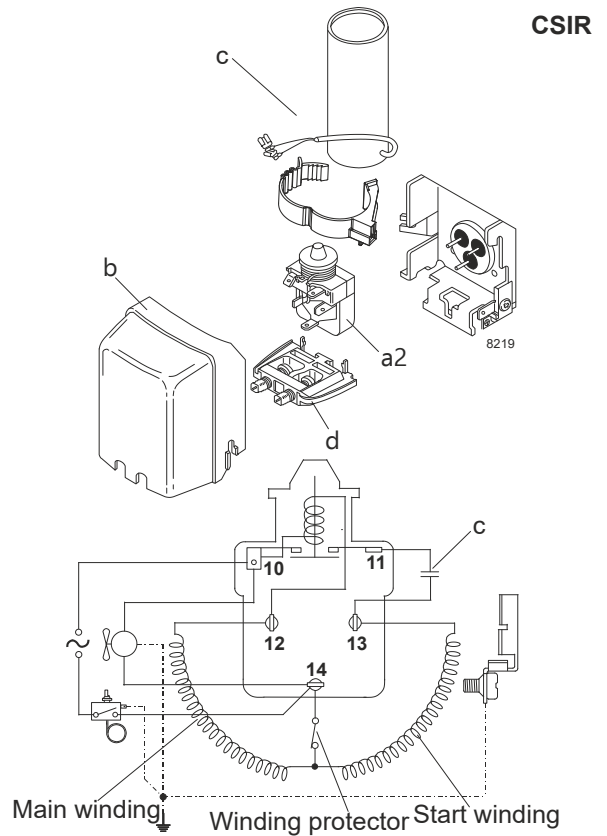

Ambient temperatures / system cooling

Ambient temperature min.:	10°C / 50°F
Ambient temperature max.:	43°C / 110°F

System cooling (n/a: outside limits)			
T ambient	LBP	MBP	HBP
32°C / 90°F	fan 1,5m/s	fan 1,5m/s	n/a
38°C / 100°F	fan 1,5m/s	fan 1,5m/s	n/a
43°C / 110°F	fan 1,5m/s	fan 1,5m/s	n/a

Operation pressure range

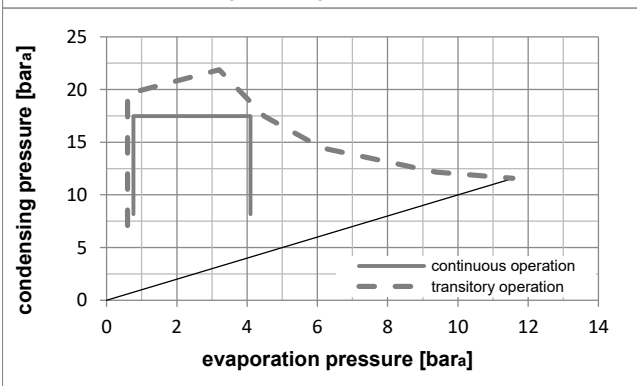
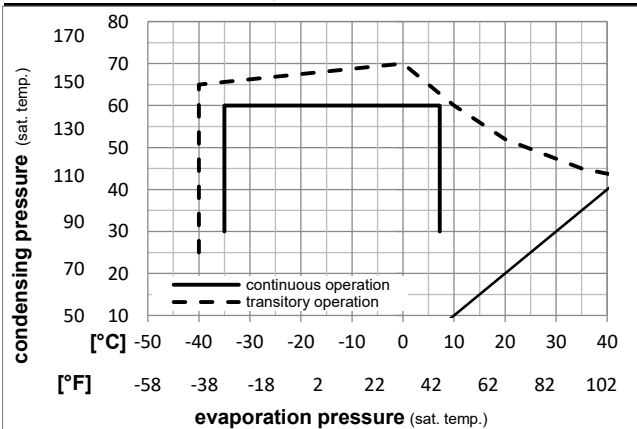

Components

a2	relay	117U6016
c	start capacitor (80µF)	117U5015
b	plastic cover	103N2011
d	cord relief	103N1010

Model

Designation **NL8.4MF 208-230V/60Hz** Conf. 5 Sales code: **105G7802**

Optimization + standard conditions

R513A, 220V/60Hz, CSIR, fan 1,5m/s, CCC, UL

Evaporating pressure (saturation temperature)		Condensing pressure (saturation temperature)				Return gas temp.		Liquid temp.		Cooling capacity		COP	EER	P1	I	Ref. mass flow	
pe	pc	RGT	Tliq		[W]	[Btu/h]	[kcal/h]	[W/W]	[Btu/Wh]	[kcal/Wh]	[W]	[A]	[kg/h]				
[°C]	7,22	54,4	35	46,1	1020,3	3484	878,1	2,14	7,29	1,84	477,8	2,54	25,35	ASHRAE			
[°F]	45	130	95	115										HBP			
[°C]	5	55	32	55	828,1	2828	712,7	1,79	6,12	1,54	462,1	2,48	23,27	cecomaf			
[°F]	41	131	89,6	131										HBP			
[°C]	5	50	20	50	864,3	2952	743,9	1,97	6,73	1,69	438,9	2,39	24,78	EN12900			
[°F]	41	122	68	122										HBP			
[°C]	-6,66	54,4	35	46,1	574,5	1962	494,4	1,59	5,43	1,37	361,0	2,09	14,07	ASHRAE			
[°F]	20	130	95	115										MBP			
[°C]	-10	55	32	55	436,0	1489	375,2	1,31	4,46	1,12	334,0	1,99	12,06	cecomaf			
[°F]	14	131	89,6	131										MBP			
[°C]	-10	45	20	45	506,1	1729	435,6	1,61	5,50	1,39	314,0	1,92	13,42	EN12900			
[°F]	14	113	68	113										MBP			

Performance tables

R513A, 220V/60Hz, CSIR, fan 1,5m/s, CCC, UL

	pe	Cooling capacity			COP	EER	P1	I	m		
	[°C]	[°F]	[W]	[Btu/h]	[kcal/h]	[W/W]	[Btu/Wh]	[kcal/Wh]	[W]	[A]	[kg/h]
[°C / °F]	-35	-31	131,3	448	113,0	0,93	3,17	0,80	141,5	1,26	3,19
cond. pressure	-25	-13	248,3	848	213,6	1,19	4,06	1,02	209,0	1,52	6,05
pc= 45/113	-15	5	418,8	1430	360,5	1,50	5,13	1,29	278,8	1,78	10,26
return gas temp.	-10	14	529,3	1808	455,5	1,69	5,76	1,45	314,0	1,92	13,01
RGT= 32/90	-5	23	659,1	2251	567,3	1,89	6,45	1,62	349,2	2,05	16,27
liquid temp	0	32	810,4	2768	697,4	2,11	7,21	1,82	384,1	2,18	20,10
Tliq= 45/113	7,2	45	1069,9	3654	920,8	2,47	8,43	2,12	433,6	2,37	26,76
[°C / °F]	-35	-31	89,1	304	76,7	0,71	2,41	0,61	126,0	1,20	2,43
cond. pressure	-25	-13	193,9	662	166,8	0,94	3,20	0,81	207,2	1,51	5,31
pc= 55/131	-15	5	341,3	1165	293,7	1,17	4,00	1,01	291,3	1,83	9,40
return gas temp	-10	14	436,0	1489	375,2	1,31	4,46	1,12	334,0	1,99	12,06
RGT= 32/90	-5	23	547,3	1869	471,1	1,45	4,96	1,25	376,8	2,15	15,20
liquid temp	0	32	677,4	2313	583,0	1,61	5,51	1,39	419,6	2,32	18,92
Tliq= 55/131	7,2	45	901,5	3079	775,9	1,88	6,41	1,61	480,6	2,55	25,41



8238-20

NL Compressors

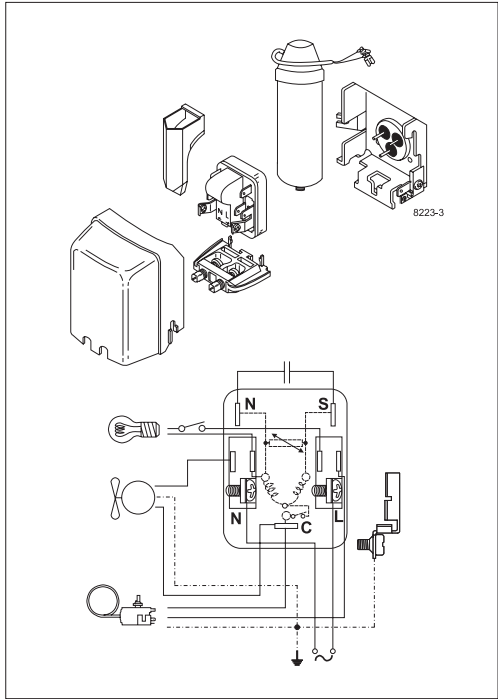
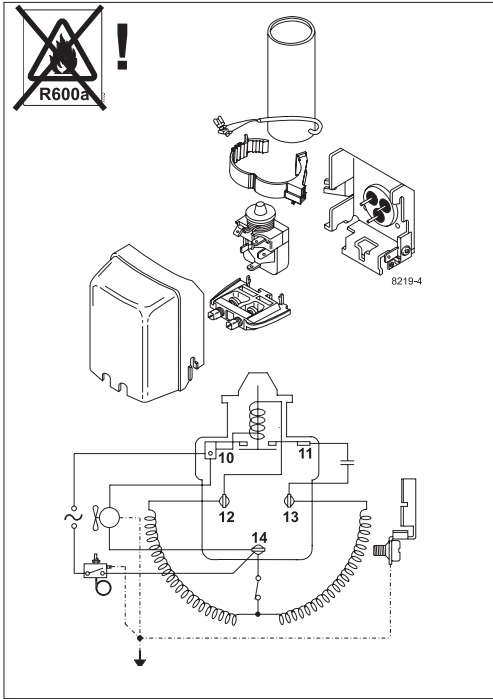
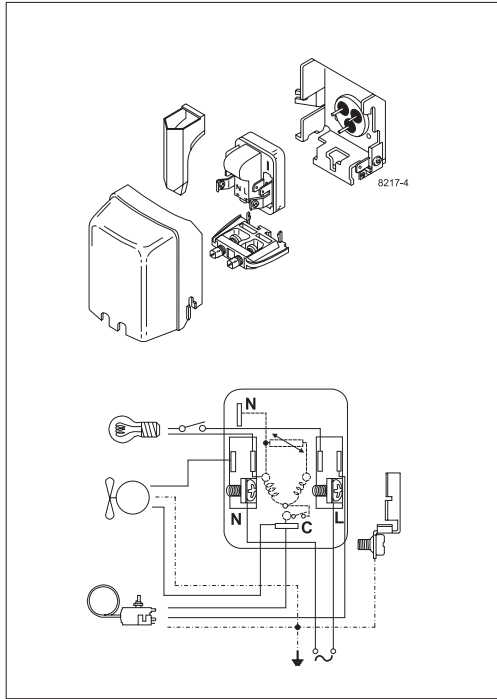



Service/Repair – R600a, R290



8545

Brazing on Suction Connectors (Direct Intake)

representative image



**! max. 150°C/302°F !
at socket**
brazing solder: phosphor (LP7) or silver

Refer to Product Bulletin:
**Brazing on Suction Connectors
(Compressors with Direct Suction Intake)**

Secop accepts no responsibility for possible errors in catalogs, brochures, and other printed material. Secop reserves the right to alter its products without notice. This also applies to products already on order provided that such alterations can be made without subsequential changes being necessary to specifications already agreed. All trademarks in this material are the property of the respective companies. Secop and the Secop logotype are trademarks of Secop GmbH. All rights reserved. www.secop.com