

Single Pack SC10MNX 220-240V 50Hz CSIR

Codice Imballo Singolo: **195B4376**

Posizione	Titolo	Codice	Quantità
1	Compressor SC10MNX	104H8075	1
2	Starting relay	117U7005	1
3	Starting capacitor (80 μ F 220V, 6.3mm)	117U5017	1
4	Cord relief	103N1004	1
5	Cover	103N2008	1
6	Bolt joint for one compressor M6 \varnothing 16mm	118-1917	1

Secop GmbH • Lise-Meitner-Straße 29 • 24941 Flensburg, Germany • Tel: +49 46149410 • www.secop.com

Secop non si assume alcuna responsabilità per eventuali errori presenti in cataloghi, brochure e altro materiale stampato. Secop si riserva il diritto di modificare i propri prodotti senza preavviso. Ciò vale anche per i prodotti già ordinati, a condizione che tali modifiche possano essere apportate senza che siano necessarie modifiche successive alle specifiche già concordate. Tutti i marchi presenti in questo materiale sono di proprietà delle rispettive aziende. Secop e il logo Secop sono marchi di Secop GmbH. Tutti i diritti sono riservati.

Model

Designation	SC10MNX	220-240V/50Hz 1~	Sales code:	104H8075
-------------	----------------	------------------	-------------	-----------------

Compressor design

Oil type	Polyolester	Refrigerant(s)	R290
Oil viscosity	22cST	Displacement	10,29cm ³ / 0,63cu.in
Oil quantity	500cm ³ / 16,9fl.oz	Compressors on pallet	80
Refr. charge - tech. limit	150g / 5,3oz		
Free gas volume comp.	1410cm ³ / 47,7fl.oz		
Weight	13,1kg / 28,9lbs		
Motor protection	1# internal		
Winding resistance main	5,13Ω (at 25°C)		
Winding resistance aux	13,51Ω (at 25°C)		
Max. winding temp.	125°C / 257°F		
Max. discharge temp.	130°C / 266°F		



General - Configurations with SC10MNX

Conf. 1

Motorconfiguration	CSIR
Power supply (nominal)	220-240V/50Hz
Number of phases	1
Voltage range	198-254V
Approvals	CCC, EAC, VDE
Starting torque	HST
Note	- / -

Applications with SC10MNX

Conf. 1

Refrigerant	R290
Application	MBP
System cooling	fan 3m/s
Hot gas defrost	OK
Long interval pull down	OK

Electrical data - Configurations with SC10MNX

Conf. 1

Starting device type	relay
Run capacitor	-/-
Start capacitor	80μF
LRA (locked rotor amps / 4s)	16,2A
RLA (rated load amps / 1s)	3,1A
Cut in current	16,2A

Model

Designation	SC10MNX	220-240V/50Hz 1~	Sales code:	104H8075
-------------	----------------	-------------------------	-------------	-----------------

Compressor dimensions

Housing	A Height	209mm / 8,23in
	B Height	203mm / 7,99in
	C Length shell	218mm / 8,58in
	D Length w. cover	255mm / 10,04in
	E Width	151mm / 5,94in

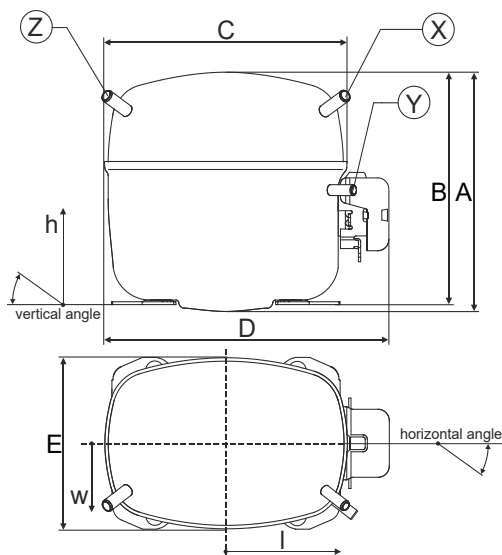

Connectors	Suction		Discharge		Process	
	X	Y	Z	X	Y	Z
Diameter [mm]	øi 8,11-8,29	øi 6,11-6,29	øi 6,11-6,29	øi 8,11-8,29	øi 6,11-6,29	øi 6,11-6,29
(i:inside, o:outside) [in]	øi 0,32-0,33	øi 0,24-0,25	øi 0,24-0,25	øi 0,32-0,33	øi 0,24-0,25	øi 0,24-0,25
Material	copper	copper	copper	copper	copper	copper
Horizontal angle ±2°	37°	37°	143°	37°	37°	143°
Vertical angle ±2°	30°	0°	150°	30°	0°	150°
Position l/h/w [mm]	107/183/55	115/100/63	-107/183/55	107/183/55	115/100/63	-107/183/55
[in]	4,2/7,2/2,2	4,5/3,9/2,5	-4,2/7,2/2,2	4,2/7,2/2,2	4,5/3,9/2,5	-4,2/7,2/2,2
Straight tube l. [mm]	12	12	12	12	12	12
[in]	0,5	0,5	0,5	0,5	0,5	0,5

Compressor fixation

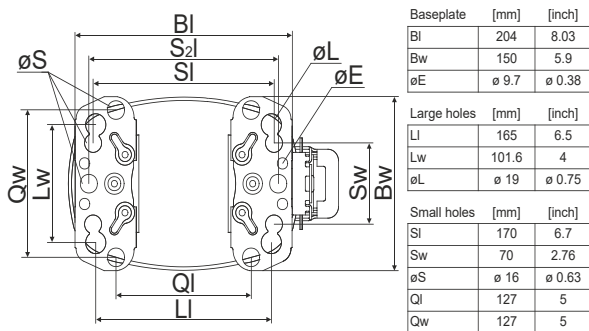

Baseplate	[mm]	[inch]
BI	204	8.03
Bw	150	5.9
øE	ø 9.7	ø 0.38
Large holes	[mm]	[inch]
LI	165	6.5
Lw	101.6	4
øL	ø 19	ø 0.75
Small holes	[mm]	[inch]
SI	170	6.7
Sw	70	2.76
øS	ø 16	ø 0.63
QI	127	5
Qw	127	5

Bolt joint

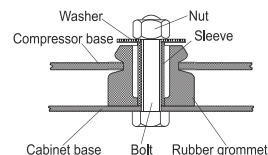

Snap-on

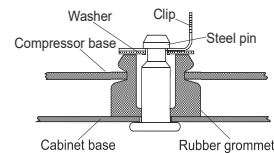

Mounting accessories

	one comp.	multi pack
Bolt joint M6 ø16mm	118-1917	118-1918
Bolt joint ø1/4" ø16mm	118-1946	
Bolt joint ø1/4" ø19mm	118-1949	
Snap-on ø7,3 ø16mm	118-1947	118-1919

Application notes

Provision for PE Grounding is located at the PE Stamp on the compressor

Model

Designation	SC10MNX	220-240V/50Hz	Conf. 1	Sales code:	104H8075
-------------	----------------	----------------------	---------	-------------	-----------------

Configuration

Motorconfiguration	CSIR
Power supply (nominal)	220-240V/50Hz 1~
Refrigerant	R290
Application	MBP
Voltage range	198-254V
Starting torque	HST
Approvals	CCC
	EAC
	VDE

Electrical accessories / wiring diagram

CSIR

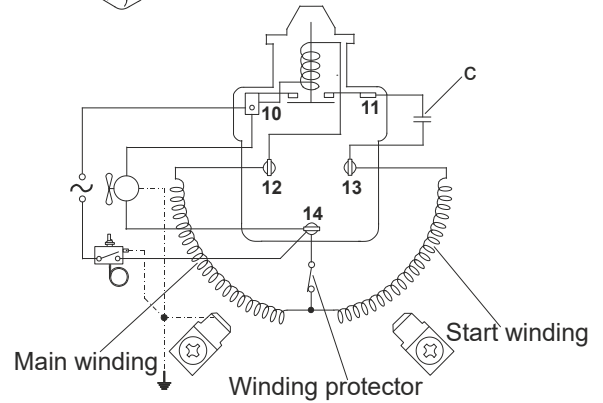
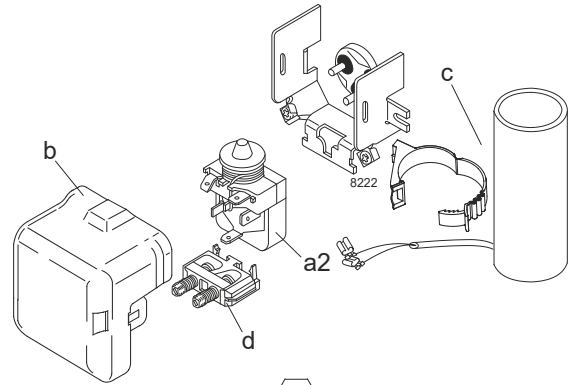

Ambient/ machine room temperatures minimum /maximum

Ambient temperature range: 10 - 43°C / 50 - 110°F

Machine room temperature range: 10 - 48°C / 50 - 119°F

Compressor cooling: fan 3m/s

Operation Limits

Operation pressure range

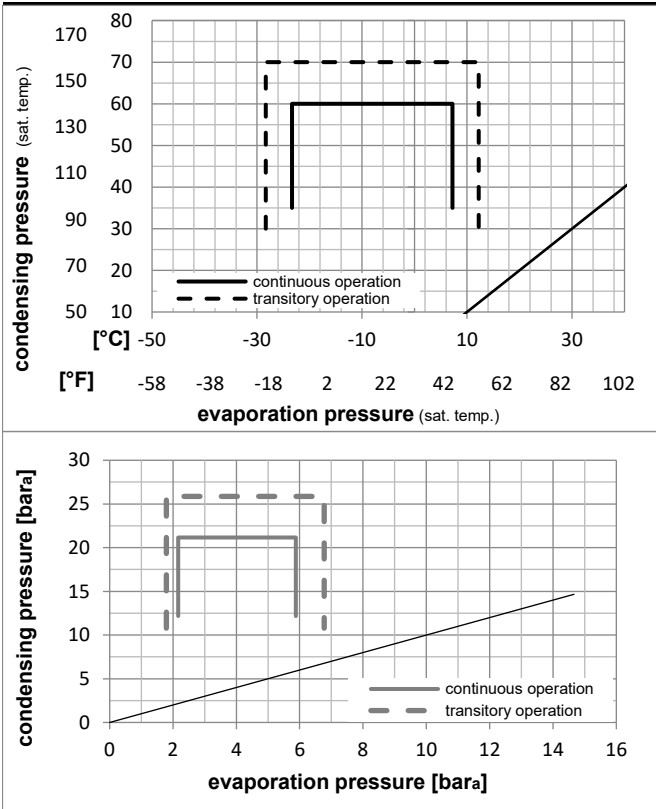

Components

a2	relay	117U7005
c	start capacitor (80µF)	117U5017
d	cord relief	103N1004
b	plastic cover	103N2009

Alternative components

a2	relay	117U7005
c	start capacitor (80µF)	117U5017
d	cord relief	103N1004
b	plastic cover	103N2008

Model

Designation **SC10MNX** **220-240V/50Hz** Conf. 1 Sales code: **104H8075**

Optimization + standard conditions

R290, 220V/50Hz, CSIR, fan 3m/s, CCC, EAC, VDE

Evaporating pressure (saturation temperature)				Condensing pressure (saturation temperature)			Cooling capacity				COP		EER		Power consumption		Ref. mass flow m		
pe	pc	RGT	Tliq	[W]	[Btu/h]	[kcal/h]	[W/W]	[Btu/Wh]	[kcal/Wh]	P1	I	[W]	[A]	[kg/h]					
[°C]	[°C]	[°C]	[°C]																
-7	54	35	46	766,7	2618	659,8	1,70	5,80	1,46	451,4	2,83	8,75						ASHRAE MBP	
[°F]																			
-10	55	32	55	593,3	2026	510,6	1,38	4,71	1,19	429,8	2,76	7,50						cecomaf MBP	
[°F]																			
-10	45	20	45	686,5	2344	590,8	1,71	5,85	1,48	400,4	2,67	8,43						EN12900 MBP	
[°F]																			
-7	49	18	49	734,0	2507	631,7	1,70	5,82	1,47	430,8	2,77	9,53						ARI540 MBP	
[°F]																			
-10	45	32	45	714,6	2441	615,0	1,78	6,09	1,54	400,4	2,67	8,18						opt	
[°F]																			
-25	45	32	45	327,7	1119	282,0	1,12	3,84	0,97	291,8	2,39	3,70						opt	
[°F]																			

Performance tables

R290, 220V/50Hz, CSIR, fan 3m/s, CCC, EAC, VDE

	pe		Cooling capacity			COP		EER		P1	I	m
	[°C]	[°F]	[W]	[Btu/h]	[kcal/h]	[W/W]	[Btu/Wh]	[kcal/Wh]	[W]	[A]	[kg/h]	
[°C / °F]	-23	-10	363,8	1242	313,1	1,18	4,03	1,02	308,4	2,42	4,11	
cond. pressure	-20	-4	439,2	1500	377,9	1,30	4,45	1,12	337,1	2,49	4,97	
pc= 45/113	-15	5	567,4	1938	488,4	1,52	5,20	1,31	372,8	2,58	6,46	
return gas temp.	-10	14	714,6	2441	615,0	1,78	6,09	1,54	400,4	2,67	8,18	
RGT= 32/90	-5	23	882,8	3015	759,8	2,09	7,15	1,80	421,7	2,74	10,16	
liquid temp	0	32	1074,1	3668	924,4	2,45	8,37	2,11	438,4	2,82	12,46	
Tliq= 45/113	7,2	45	1394,5	4762	1200,1	3,05	10,40	2,62	457,7	2,91	16,38	
[°C / °F]	-23	-10	282,6	965	243,2	0,96	3,29	0,83	293,1	2,43	3,52	
cond. pressure	-20	-4	349,7	1194	300,9	1,05	3,57	0,90	334,4	2,51	4,37	
pc= 55/131	-15	5	463,3	1582	398,7	1,20	4,09	1,03	387,2	2,64	5,83	
return gas temp	-10	14	593,3	2026	510,6	1,38	4,71	1,19	429,8	2,76	7,50	
RGT= 32/90	-5	23	741,7	2533	638,3	1,60	5,46	1,38	463,9	2,87	9,45	
liquid temp	0	32	910,6	3110	783,6	1,85	6,33	1,60	491,0	2,98	11,70	
Tliq= 55/131	7,2	45	1194,1	4078	1027,7	2,29	7,82	1,97	521,6	3,12	15,56	



SC Compressors





SC Compressors

Service/Repair – R290



8545



Secop accepts no responsibility for possible errors in catalogs, brochures, and other printed material. Secop reserves the right to alter its products without notice. This also applies to products already on order provided that such alterations can be made without subsequent changes being necessary to specifications already agreed. All trademarks in this material are the property of the respective companies. Secop and the Secop logotype are trademarks of Secop GmbH. All rights reserved. www.secop.com