

Single Pack SC18FTX 220-240V 50/60Hz CSIR

Codice Imballo Singolo: **195B4480**

Posizione	Titolo	Codice	Quantità
1	Compressor SC18FTX	104G8805	1
2	Starting relay	117U6019	1
3	Starting capacitor (80 μ F 220V, 6.3mm)	117U5017	1
4	Cord relief	103N1004	1
5	Cover	103N2009	1
6	Bolt joint for one compressor M6 \varnothing 16mm	118-1917	1

Secop GmbH • Lise-Meitner-Straße 29 • 24941 Flensburg, Germany • Tel: +49 46149410 • www.secop.com

Secop non si assume alcuna responsabilità per eventuali errori presenti in cataloghi, brochure e altro materiale stampato. Secop si riserva il diritto di modificare i propri prodotti senza preavviso. Ciò vale anche per i prodotti già ordinati, a condizione che tali modifiche possano essere apportate senza che siano necessarie modifiche successive alle specifiche già concordate. Tutti i marchi presenti in questo materiale sono di proprietà delle rispettive aziende. Secop e il logo Secop sono marchi di Secop GmbH. Tutti i diritti sono riservati.

Model

Designation	SC18FTX	220-240V/50Hz 1~ 220-240V/60Hz 1~	Sales code:	104G8805
-------------	----------------	-----------------------------------	-------------	-----------------

Compressor design

Oil type	Polyolester	Refrigerant(s)	R134a
Oil viscosity	22cST	Displacement	17,69cm ³ / 1,08cu.in
Oil quantity	550cm ³ / 18,6fl.oz	Compressors on pallet	80
Refr. charge - tech. limit	1300g / 45,9oz		
Free gas volume comp.	1460cm ³ / 49,4fl.oz		
Weight	13,8kg / 30,4lbs		
Motor protection	1# internal		
Winding resistance main	3,7Ω (at 25°C)		
Winding resistance aux	14Ω (at 25°C)		
Max. winding temp.	125°C / 257°F		
Max. discharge temp.	135°C / 275°F		



General - Configurations with SC18FTX

	Conf. 1	Conf. 2
Motorconfiguration	CSIR	CSIR
Power supply (nominal)	220-240V/50Hz	208-230V/60Hz
Number of phases	1	1
Voltage range	187-254V	198-254V
Approvals	CCC, EAC, VDE, KC	CCC, EAC, VDE, KC
Starting torque	HST	HST
Note	- / -	

Applications with SC18FTX

	Conf. 1	Conf. 2
Refrigerant	R134a	R134a
Application	LBP	LBP
System cooling	fan 3m/s	fan 3m/s
Hot gas defrost	OK	OK
Long interval pull down	OK	OK

Electrical data - Configurations with SC18FTX

	Conf. 1	Conf. 2
Starting device type	relay	relay
Run capacitor	- / -	- / -
Start capacitor	80μF	80μF
LRA (locked rotor amps / 4s)		
RLA (rated load amps / 1s)	- / A	- / A
Cut in current		

Model

Designation

SC18FTX

220-240V/50Hz 1~ 220-240V/60Hz 1~

Sales code:

104G8805

Compressor dimensions

Housing	A Height	219mm / 8,62in
	B Height	213mm / 8,39in
	C Length shell	218mm / 8,58in
	D Length w. cover	255mm / 10,04in
	E Width	151mm / 5,94in

Connectors	Suction X	Discharge Y	Process Z
Diameter [mm]	øi 10,11-10,29	øi 6,11-6,29	øi 6,11-6,29
(i:inside, o:outside) [in]	øi 0,4-0,41	øi 0,24-0,25	øi 0,24-0,25
Material	copper	copper	copper
Horizontal angle ±2°	37°	37°	143°
Vertical angle ±2°	30°	0°	150°
Position l/h/w [mm]	107/193/55	115/110/63	-107/193/55
[in]	4,2/7,6/2,2	4,5/4,3/2,5	-4,2/7,6/2,2
Straight tube l. [mm]	12	12	12
[in]	0,5	0,5	0,5



Compressor fixation



Bolt joint



Snap-on



Mounting accessories

Mounting accessories	one comp.	multi pack
Bolt joint M6 ø16mm	118-1917	118-1918
Bolt joint ø1/4" ø16mm	118-1946	
Bolt joint ø1/4" ø19mm	118-1949	
Snap-on ø7,3 ø16mm	118-1947	118-1919

Application notes

Provision for PE Grounding is located at the PE Stamp on the compressor

Model

Designation	SC18FTX	220-240V/50Hz	Conf. 1	Sales code:	104G8805
-------------	----------------	----------------------	----------------	-------------	-----------------

Configuration

Motorconfiguration	CSIR
Power supply (nominal)	220-240V/50Hz 1~
Refrigerant	R134a
Application	LBP
Voltage range	187-254V
Starting torque	HST
Approvals	CCC EAC VDE KC

Electrical accessories / wiring diagram



Ambient/ machine room temperatures minimum /maximum

Ambient temperature range:	10 - 43°C / 50 - 110°F
Machine room temperature range:	10 - 48°C / 50 - 119°F
Compressor cooling:	fan 3m/s

Operation Limits

Operation pressure range

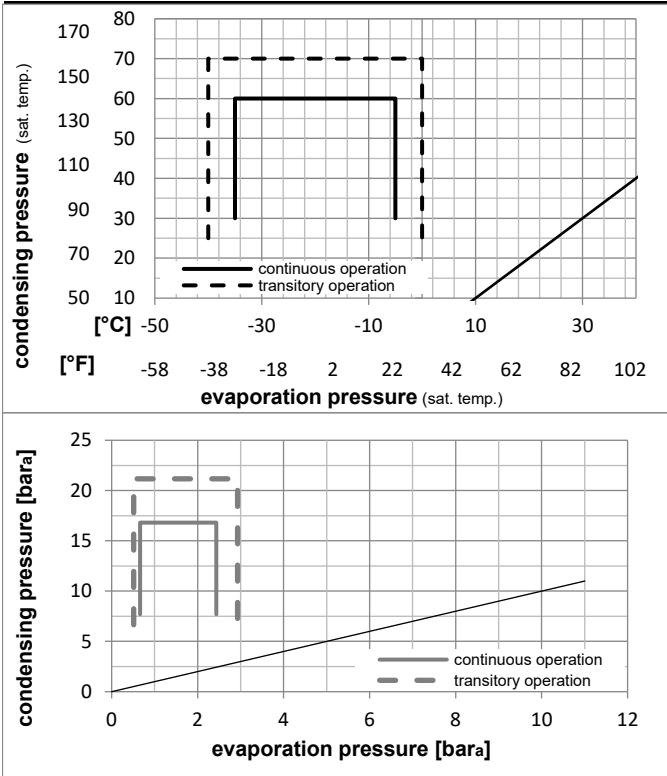

Components

a2	relay	117U6019
c	start capacitor (80μF)	117U5017
d	cord relief	103N1004
b	plastic cover	103N2009

Model

Designation **SC18FTX** **220-240V/50Hz** Conf. 1 Sales code: **104G8805**

Optimization + standard conditions

R134a, 220V/50Hz, CSIR, fan 3m/s, CCC, EAC, VDE, KC

	Evaporating pressure (saturation temperature)				Condensing pressure (saturation temperature)			Return gas temp.	Liquid temp.	Cooling capacity	COP	EER	Power consumption			ASHRAE LBP
	pe	pc	RGT	Tliq	[W]	[Btu/h]	[kcal/h]						P1	I	Ref. mass flow	
[°C]																
[°F]																
	-23	54	32	32	446,4	1525	384,2	1,17	3,99	1,00	382,5	2,94	8,67			
	-10	130	90	90												
	-25	55	32	55	325,0	1110	279,7	0,89	3,04	0,77	365,4	2,87	7,77			
	-13	131	90	131												
	-35	40	20	40	216,6	740	186,4	0,79	2,71	0,68	273,4	2,56	4,75			
	-31	104	68	104												
	-23	49	4,4	49	370,8	1266	319,1	0,97	3,33	0,84	380,4	2,93	9,79			
	-10	120	40	120												
	-23	41	32	32	502,7	1717	432,6	1,36	4,65	1,17	369,0	2,91	9,76			
	-10	105	90	90												
	-35	45	32	45	199,1	680	171,4	0,73	2,50	0,63	272,1	2,56	4,30			opt
	-31	113	90	113												

Performance tables

R134a, 220V/50Hz, CSIR, fan 3m/s, CCC, EAC, VDE, KC

	pe		Cooling capacity			COP	EER	P1	I	m	
	[°C]	[°F]	[W]	[Btu/h]	[kcal/h]	[W/W]	[Btu/Wh]	[kcal/Wh]	[W]	[A]	[kg/h]
[°C / °F]	-35	-31	199,1	680	171,4	0,73	2,50	0,63	272,1	2,56	4,30
cond. pressure	-30	-22	286,1	977	246,2	0,90	3,07	0,77	317,7	2,71	6,18
pc= 45/113	-25	-13	393,3	1343	338,5	1,09	3,72	0,94	361,6	2,87	8,52
return gas temp.	-23	-10	435,0	1486	374,4	1,16	3,95	0,99	376,4	2,92	9,43
RGT= 32/90	-20	-4	524,1	1790	451,0	1,29	4,42	1,11	405,2	3,04	11,39
liquid temp	-15	5	681,6	2328	586,6	1,51	5,17	1,30	450,2	3,22	14,86
Tliq= 45/113	-5	23	1089,5	3721	937,7	1,98	6,76	1,70	550,3	3,63	23,96
[°C / °F]	-35	-31	144,2	493	124,1	0,56	1,92	0,48	256,9	2,52	3,43
cond. pressure	-30	-22	228,6	781	196,7	0,73	2,49	0,63	312,9	2,69	5,45
pc= 55/131	-25	-13	325,0	1110	279,7	0,89	3,04	0,77	365,4	2,87	7,77
return gas temp	-23	-10	361,1	1233	310,7	0,94	3,22	0,81	382,8	2,94	8,64
RGT= 32/90	-20	-4	436,7	1491	375,8	1,05	3,59	0,90	415,9	3,07	10,47
liquid temp	-15	5	566,9	1936	487,8	1,22	4,15	1,05	466,0	3,27	13,65
Tliq= 55/131	-5	23	895,6	3059	770,8	1,57	5,36	1,35	570,9	3,72	21,77

Model

Designation	SC18FTX	208-230V/60Hz	Conf. 2	Sales code:	104G8805
-------------	----------------	----------------------	----------------	-------------	-----------------

Configuration

Motorconfiguration	CSIR
Power supply (nominal)	208-230V/60Hz 1~
Refrigerant	R134a
Application	LBP
Voltage range	198-254V
Starting torque	HST
Approvals	CCC EAC VDE KC

Electrical accessories / wiring diagram

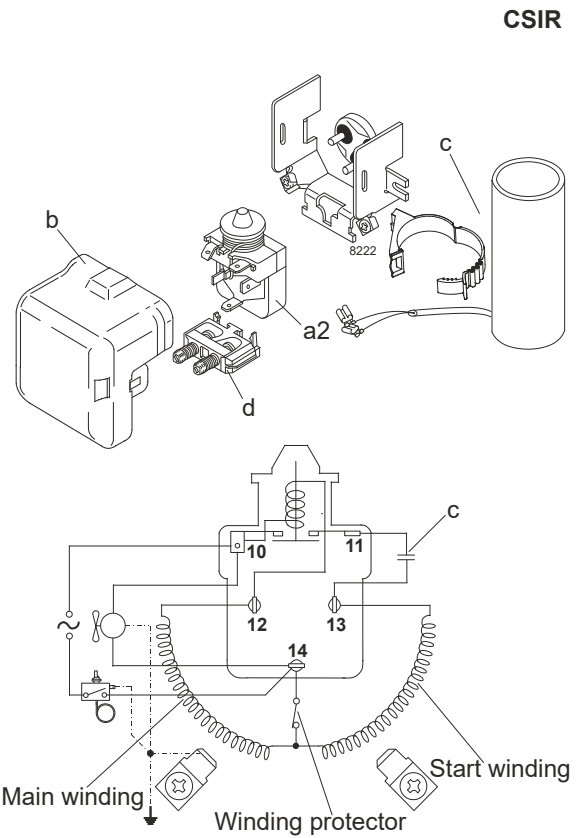

Ambient/ machine room temperatures minimum /maximum

Ambient temperature range:	10 - 43°C / 50 - 110°F
Machine room temperature range:	10 - 48°C / 50 - 119°F
Compressor cooling:	fan 3m/s

Operation Limits

Operation pressure range

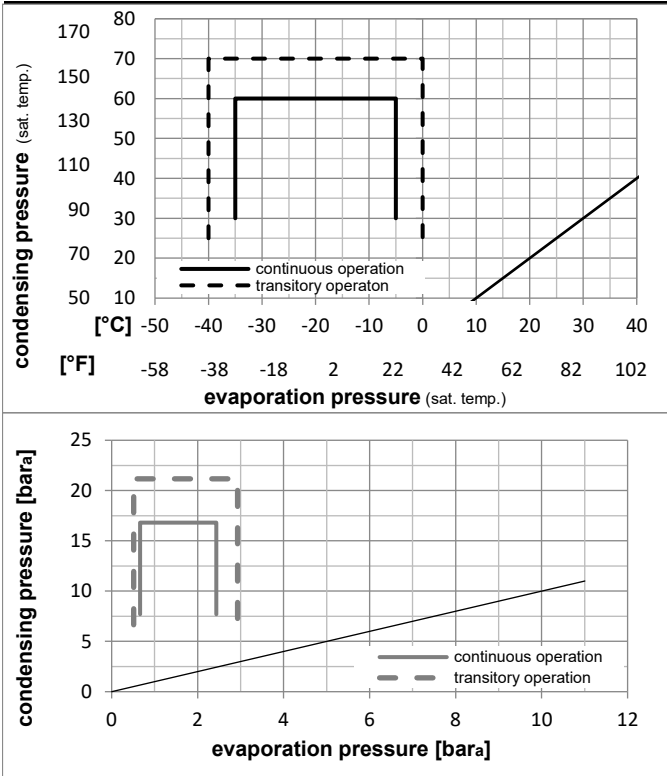

Components

a2	relay	117U6019
c	start capacitor (80μF)	117U5017
d	cord relief	103N1004
b	plastic cover	103N2009

Model

Designation **SC18FTX** **208-230V/60Hz** Conf. 2 Sales code: **104G8805**

Optimization + standard conditions

R134a, 220V/60Hz, CSIR, fan 3m/s, CCC, EAC, VDE, KC

	pe	pc	RGT	Tliq	Cooling capacity	COP	EER	P1	I	Ref. mass flow	
	[°C]	[°C]	[°C]	[°C]	[W]	[W/W]	[Btu/Wh]	[W]	[A]	[kg/h]	
	[°F]	[°F]	[°F]	[°F]	[Btu/h]	[kcal/h]	[kcal/Wh]	[W]	[A]	[kg/h]	
ASHRAE LBP	-23	54	32	32	533,8	1,20	4,11	443,3	2,77	10,36	
	-10	130	90	90			1,04				
cecomaf LBP	-25	55	32	55	389,7	0,93	3,17	419,7	2,66	9,32	
	-13	131	90	131			0,80				
EN12900 LBP	-35	40	20	40	279,1	0,91	3,09	308,3	2,20	6,12	
	-31	104	68	104			0,78				
ARI540 LBP	-23	49	4,4	49	446,5	1,01	3,43	444,0	2,77	11,79	
	-10	120	40	120			0,87				
AHAM LBP	-23	41	32	32	618,7	1,40	4,79	441,0	2,76	12,01	
	-10	105	90	90			1,21				
opt	-35	45	32	45	253,6	0,85	2,90	298,9	2,16	5,47	
	-31	113	90	113			0,73				

Performance tables

R134a, 220V/60Hz, CSIR, fan 3m/s, CCC, EAC, VDE, KC

	pe	Cooling capacity	COP	EER	P1	I	m
	[°C]	[W]	[W/W]	[Btu/Wh]	[W]	[A]	[kg/h]
	[°F]	[Btu/h]	[kcal/Wh]	[kcal/Wh]	[W]	[A]	[kg/h]
[°C / °F]	-35 -31	253,6 866	0,85 2,90	2,90 0,73	298,9	2,16	5,47
cond. pressure	-30 -22	354,2 1209	0,98 3,34	0,84 3,34	361,9	2,42	7,65
pc= 45/113	-25 -13	479,6 1638	1,13 3,87	0,98 3,87	423,1	2,68	10,39
return gas temp.	-23 -10	528,6 1805	1,19 4,07	1,03 4,07	443,5	2,77	11,46
RGT= 32/90	-20 -4	633,7 2164	1,31 4,48	1,13 4,48	482,7	2,94	13,77
liquid temp	-15 5	820,1 2801	1,52 5,18	1,30 5,18	540,9	3,21	17,88
Tliq= 45/113	-5 23	1304,2 4454	2,00 6,81	1,72 6,81	653,6	3,75	28,68
[°C / °F]	-35 -31	186,7 637	0,68 2,33	0,59 2,33	274,1	2,05	4,44
cond. pressure	-30 -22	279,8 955	0,80 2,74	0,69 2,74	348,1	2,36	6,67
pc= 55/131	-25 -13	389,7 1331	0,93 3,17	0,80 3,17	419,7	2,66	9,32
return gas temp	-23 -10	431,6 1474	0,97 3,32	0,84 3,32	443,6	2,77	10,33
RGT= 32/90	-20 -4	520,2 1777	1,06 3,63	0,92 3,63	489,1	2,97	12,48
liquid temp	-15 5	674,8 2305	1,21 4,14	1,04 4,14	556,5	3,28	16,25
Tliq= 55/131	-5 23	1071,3 3659	1,56 5,33	1,34 5,33	685,9	3,90	26,04



SC Compressors





SC Compressors

Service/Repair – R290



8545



Secop accepts no responsibility for possible errors in catalogs, brochures, and other printed material. Secop reserves the right to alter its products without notice. This also applies to products already on order provided that such alterations can be made without subsequent changes being necessary to specifications already agreed. All trademarks in this material are the property of the respective companies. Secop and the Secop logotype are trademarks of Secop GmbH. All rights reserved. www.secop.com