

Single Pack SC12MLX 115-127V 60Hz CSIR

Codice Imballo Singolo: **195B4496**

Posizione	Titolo	Codice	Quantità
1	Compressor SC12MLX	104L1606	1
2	Starting relay (RVA 7AA3R435)	117-7441	1
3	Starting capacitor (410µF 125V, 6.3mm)	117U5042	1
4	Bolt joint for one compressor M6 ø16mm	118-1917	1

Secop GmbH • Lise-Meitner-Straße 29 • 24941 Flensburg, Germany • Tel: +49 46149410 • www.secop.com

Secop non si assume alcuna responsabilità per eventuali errori presenti in cataloghi, brochure e altro materiale stampato. Secop si riserva il diritto di modificare i propri prodotti senza preavviso. Ciò vale anche per i prodotti già ordinati, a condizione che tali modifiche possano essere apportate senza che siano necessarie modifiche successive alle specifiche già concordate. Tutti i marchi presenti in questo materiale sono di proprietà delle rispettive aziende. Secop e il logo Secop sono marchi di Secop GmbH. Tutti i diritti sono riservati.

Model

Designation	SC12MLX	115-127V/60Hz 1~	Sales code:	104L1606
-------------	----------------	-------------------------	-------------	-----------------

Compressor design

Oil type	Polyolester	Refrigerant(s)	R404A, R507
Oil viscosity	32cST	Displacement	12,87cm ³ / 0,79cu.in
Oil quantity	556cm ³ / 18,8fl.oz	Compressors on pallet	80
Refr. charge - tech. limit	1300g / 45,9oz		
Free gas volume comp.	1460cm ³ / 49,4fl.oz		
Weight	13,8kg / 30,4lbs		
Motor protection	external		
Winding resistance main	0,66Ω (at 25°C)		
Winding resistance aux	2,7Ω (at 25°C)		
Max. winding temp.	125°C / 257°F		
Max. discharge temp.	130°C / 266°F		



General - Configurations with SC12MLX

	Conf. 1	Conf. 2
Motorconfiguration	CSIR	CSCR
Power supply (nominal)	115-127V/60Hz	115-127V/60Hz
Number of phases	1	1
Voltage range	95-135V	95-135V
Approvals	UL	UL
Starting torque	HST	HST
Note	Protector and cover are included and pre-assembled to compressor.	

Applications with SC12MLX

	Conf. 1	Conf. 2
Refrigerant	R404A	R404A
Application	MBP	MBP
System cooling	fan 3m/s	fan 3m/s
Hot gas defrost	OK	OK
Long interval pull down	OK	OK

Electrical data - Configurations with SC12MLX

	Conf. 1	Conf. 2
Starting device type	relay	relay
Run capacitor	-/-	23,5μF
Start capacitor	410μF	410μF
LRA (locked rotor amps / 4s)	56,8A	54,2A
RLA (rated load amps / 1s)	9,8A	8,8A
Cut in current	56,8A	54,2A

Model

Designation	SC12MLX	115-127V/60Hz 1~	Sales code:	104L1606
-------------	----------------	-------------------------	-------------	-----------------

Compressor dimensions

Housing	A Height	219mm / 8,62in
	B Height	213mm / 8,39in
	C Length shell	218mm / 8,58in
	D Length w. cover	255mm / 10,04in
	E Width	151mm / 5,94in

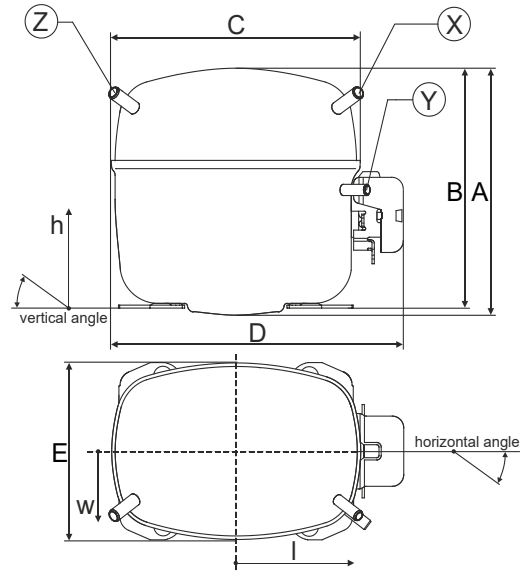

Connectors		Suction	Discharge	Process
		X	Y	Z
Diameter	[mm]	øi 8,11-8,29	øi 6,41-6,59	øi 6,41-6,59
	(i:inside, o:outside) [in]	øi 0,32-0,33	øi 0,25-0,26	øi 0,25-0,26
Material		copper	copper	copper
Horizontal angle	±2°	37°	37°	143°
Vertical angle	±2°	30°	0°	150°
Position l/h/w	[mm]	107/193/55	115/110/63	-107/193/55
	[in]	4,2/7,6/2,2	4,5/4,3/2,5	-4,2/7,6/2,2
Straight tube l.	[mm]	12	12	12
	[in]	0,5	0,5	0,5

Compressor fixation

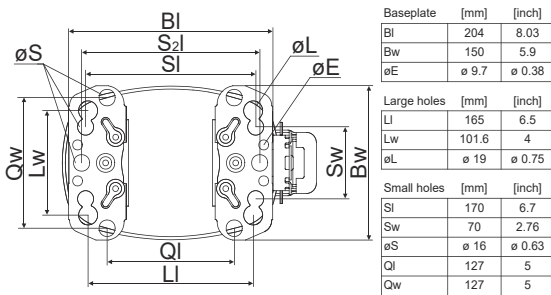

Bolt joint

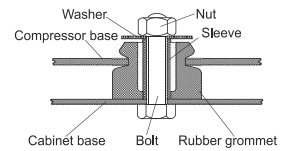

Snap-on

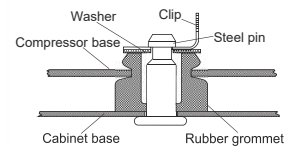

Mounting accessories

	one comp.	multi pack
Bolt joint M6 ø16mm	118-1917	118-1918
Bolt joint ø1/4" ø16mm	118-1946	
Bolt joint ø1/4" ø19mm	118-1949	
Snap-on ø7,3 ø16mm	118-1947	118-1919

Application notes

LRA value on compressor label and datasheet may differ due to different test conditions for UL approval.

Model

Designation	SC12MLX	115-127V/60Hz	Conf. 1	Sales code:	104L1606
-------------	----------------	----------------------	----------------	-------------	-----------------

Configuration

Motorconfiguration	CSIR	
Power supply (nominal)	115-127V/60Hz 1~	
Refrigerant	R404A	
Application	MBP	
Voltage range	95-135V	
Starting torque	HST	
Approvals	UL	SA3693

Electrical accessories / wiring diagram

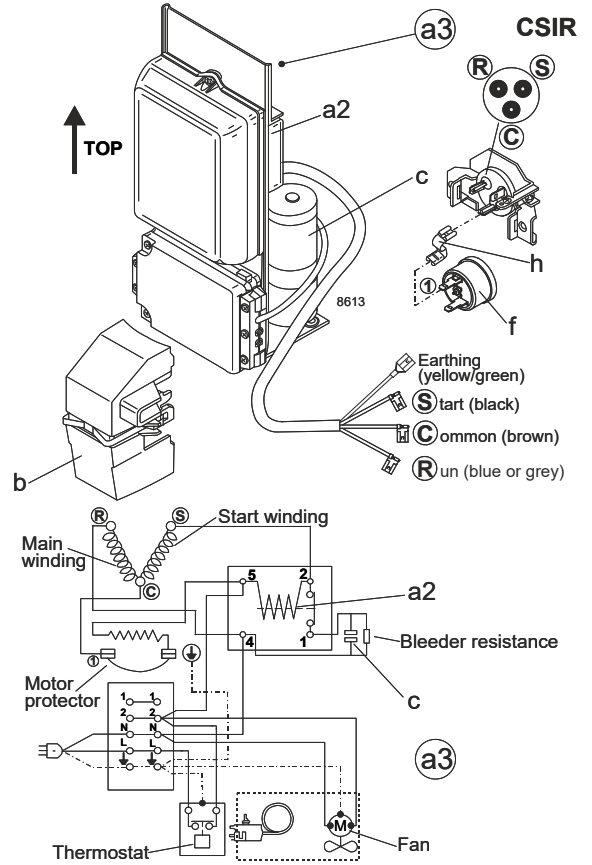

Ambient temperatures / system cooling

Ambient temperature min.:	10°C / 50°F
Ambient temperature max.:	43°C / 110°F

System cooling (n/a: outside limits)			
T ambient	LBP	MBP	HBP
32°C / 90°F	n/a	fan 3m/s	n/a
38°C / 100°F	n/a	fan 3m/s	n/a
43°C / 110°F	n/a	fan 3m/s	n/a

Operation pressure range

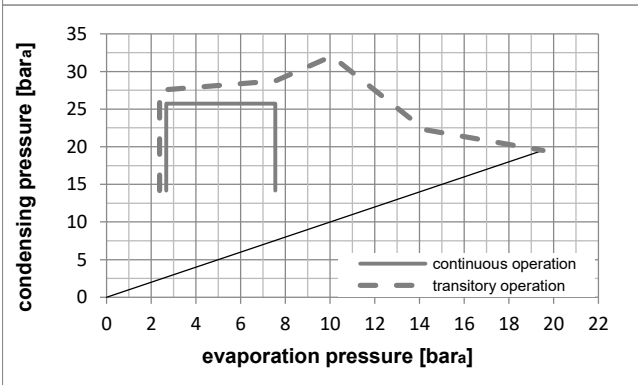
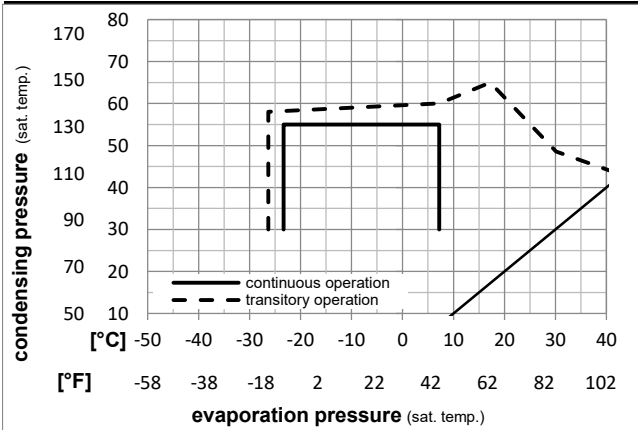

Components (protector + ~holder + cover: pre assembled)

a3	SC starter kit	117-7053
f	ext. protector (T0761/46)	117U3212
h	protector holder	117U0439
b	plastic cover	117U1021

Alternative comp. (protector + ~holder + cover: pre assemb.)

a2	potential relay (RVA 7AA3R)	117-7441
c	start capacitor (410µF, 6.3mm)	117U5042
f	ext. protector (T0761/46)	117U3212
h	protector holder	117U0439
b	plastic cover	117U1021

Model

Designation **SC12MLX 115-127V/60Hz** Conf. 1 Sales code: **104L1606**

Optimization + standard conditions

R404A, 115V/60Hz, CSIR, fan 3m/s, UL

		Evaporating pressure (saturation temperature)				Condensing pressure (saturation temperature)					Power consumption								
						Return gas temp.			Liquid temp.		Cooling capacity			COP	EER	P1	I	Ref. mass flow	
		pe	pc	RGT	Tliq	[W]	[Btu/h]	[kcal/h]	[W/W]	[Btu/Wh]	[kcal/Wh]	[W]	[A]	[kg/h]					
[°C]	-6,66	54,4	35	46,1	1284,6	4387	1105,6	1,52	5,20	1,31	844,0	9,09	35,35	ASHRAE					
[°F]	20	130	95	115										MBP					
[°C]	-10	55	32	55	950,6	3246	818,1	1,20	4,10	1,03	791,2	8,92	30,43	cecomaf					
[°F]	14	131	89,6	131										MBP					
[°C]	-10	45	20	45	1125,2	3843	968,3	1,51	5,14	1,30	747,3	8,30	33,89	EN12900					
[°F]	14	113	68	113										MBP					
[°C]	-6,66	48,9	18,3	48,9	1173,2	4007	1009,7	1,44	4,93	1,24	812,9	8,88	38,34	ARI540					
[°F]	20	120	65	120										MBP					
[°C]	-10	45	32	45	1194,1	4078	1027,7	1,60	5,46	1,38	747,3	8,30	32,88	opt					
[°F]	14	113	89,6	113															
[°C]	-25	45	32	45	606,0	2070	521,6	1,09	3,72	0,94	555,9	6,50	16,35	opt					
[°F]	-13	113	89,6	113															

Performance tables

R404A, 115V/60Hz, CSIR, fan 3m/s, UL

	pe	Cooling capacity				COP	EER	P1	I	m	
	[°C]	[°F]	[W]	[Btu/h]	[kcal/h]	[W/W]	[Btu/Wh]	[kcal/Wh]	[W]	[A]	[kg/h]
[°C / °F]	-25	-13	606,0	2070	521,6	1,09	3,72	0,94	555,9	6,50	16,35
cond. pressure	-23,3	-10	657,0	2244	565,4	1,14	3,89	0,98	576,7	6,85	17,75
pc= 45/113	-15	5	963,9	3292	829,5	1,41	4,82	1,22	682,3	7,90	26,33
return gas temp.	-9,4	15	1222,0	4173	1051,7	1,62	5,53	1,39	754,6	8,35	33,69
RGT= 32/90	-3,9	25	1528,5	5220	1315,4	1,84	6,29	1,59	829,5	8,97	42,59
liquid temp	0	32	1774,2	6059	1526,9	2,01	6,86	1,73	883,7	9,69	49,88
Tliq= 45/113	7,2	45	2304,7	7871	1983,4	2,33	7,95	2,00	989,7	12,08	66,09
[°C / °F]	-25	-13	453,7	1549	390,4	0,84	2,88	0,72	538,6	6,61	14,18
cond. pressure	-23,3	-10	496,7	1696	427,4	0,88	2,99	0,75	567,0	7,11	15,56
pc= 55/131	-15	5	755,6	2581	650,3	1,07	3,65	0,92	707,5	8,55	23,96
return gas temp	-9,4	15	974,3	3327	838,5	1,22	4,16	1,05	800,5	8,95	31,22
RGT= 32/90	-3,9	25	1235,1	4218	1062,9	1,38	4,72	1,19	893,9	9,27	40,09
liquid temp	0	32	1445,3	4936	1243,8	1,51	5,14	1,30	959,9	9,63	47,40
Tliq= 55/131	7,2	45	1901,9	6495	1636,8	1,75	5,99	1,51	1085,0	11,03	63,83

Model

Designation	SC12MLX	115-127V/60Hz	Conf. 2	Sales code:	104L1606
-------------	----------------	----------------------	----------------	-------------	-----------------

Configuration

Motorconfiguration	CSCR	
Power supply (nominal)	115-127V/60Hz 1~	
Refrigerant	R404A	
Application	MBP	
Voltage range	95-135V	
Starting torque	HST	
Approvals	UL	SA3693

Electrical accessories / wiring diagram

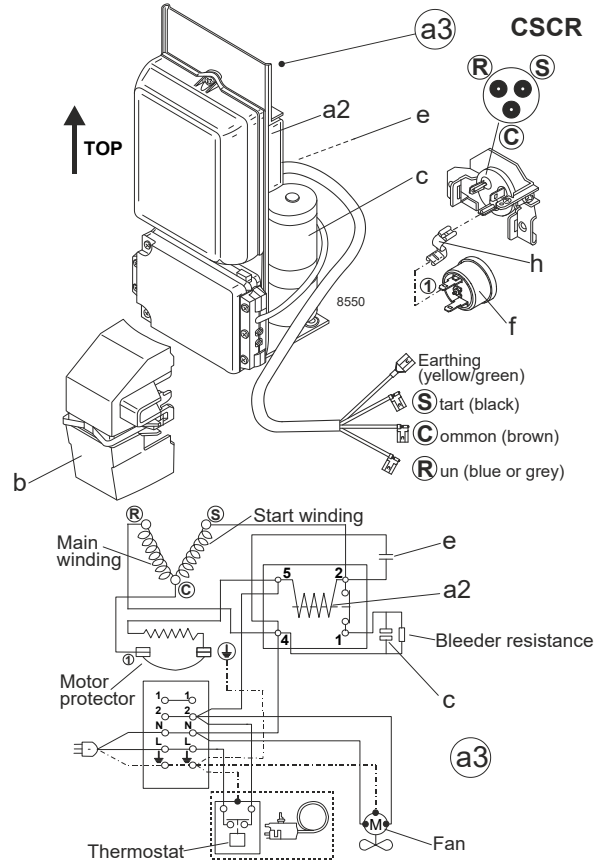

Ambient temperatures / system cooling

Ambient temperature min.:	10°C / 50°F
Ambient temperature max.:	43°C / 110°F

System cooling (n/a: outside limits)			
T ambient	LBP	MBP	HBP
32°C / 90°F	n/a	fan 3m/s	n/a
38°C / 100°F	n/a	fan 3m/s	n/a
43°C / 110°F	n/a	fan 3m/s	n/a

Operation pressure range

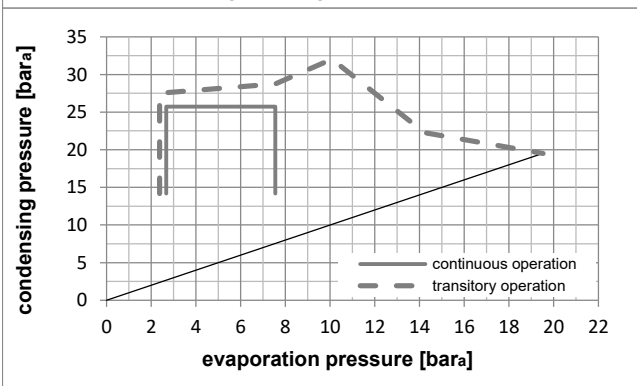
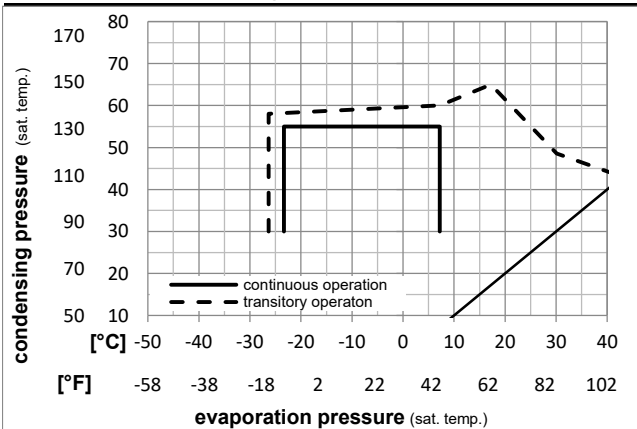

Components (protector + ~holder + cover: pre assembled)

a3	SC starter kit	117-7045
f	ext. protector (T0761/46)	117U3212
h	protector holder	117U0439
b	plastic cover	117U1021

Alternative comp. (protector + ~holder + cover: pre assemb.)

a2	potential relay (RVA 7AA3R)	117-7441
f	ext. protector (T0761/46)	117U3212
h	protector holder	117U0439
c	start capacitor (410µF, 6.3mm)	117U5042
c	start capacitor (410µF, 6.3mm)	117U5379
e	run capacitor (23,5µF, 6.3mm)	117-7133

Model

Designation **SC12MLX 115-127V/60Hz** Conf. 2 Sales code: **104L1606**

Optimization + standard conditions

R404A, 115V/60Hz, CSCR, fan 3m/s, UL

Evaporating pressure (saturation temperature)					Condensing pressure (saturation temperature)						Power consumption			ASHRAE MBP
Return gas temp.					Liquid temp.						Current consumption		Ref. mass flow ṁ	
Cooling capacity					COP		EER		P1	I				
pe	pc	RGT	Tliq	[W]	[Btu/h]	[kcal/h]	[W/W]	[Btu/Wh]	[kcal/Wh]	[W]	[A]	[kg/h]		
[°C]	-6,7	54,4	35	46,1	1300,3	4441	1119,0	1,61	5,48	1,38	809,6	8,05	35,78	ASHRAE MBP
[°F]	20	130	95	115										
[°C]	-10	55	32	55	961,9	3285	827,8	1,27	4,32	1,09	760,0	7,70	30,79	cecomaf MBP
[°F]	14	131	89,6	131										
[°C]	-10	45	20	45	1138,4	3888	979,8	1,59	5,42	1,37	717,6	7,42	34,29	EN12900 MBP
[°F]	14	113	68	113										
[°C]	-6,7	48,9	18,3	48,9	1187,3	4055	1021,8	1,52	5,20	1,31	780,1	7,84	38,80	ARI540 MBP
[°F]	20	120	65	120										
[°C]	-10	45	32	45	1208,2	4126	1039,8	1,68	5,75	1,45	717,6	7,42	33,27	opt
[°F]	14	113	89,6	113										
[°C]	-25	45	32	45	613,0	2093	527,5	1,15	3,91	0,99	534,8	6,16	16,53	opt
[°F]	-13	113	89,6	113										

Performance tables

R404A, 115V/60Hz, CSCR, fan 3m/s, UL

	pe		Cooling capacity			COP		EER		P1	I	m
	[°C]	[°F]	[W]	[Btu/h]	[kcal/h]	[W/W]	[Btu/Wh]	[kcal/Wh]	[W]	[A]	[kg/h]	
[°C / °F]	-25	-13	613,0	2093	527,5	1,15	3,91	0,99	534,8	6,16	16,53	
cond. pressure	-23	-10	664,5	2269	571,9	1,20	4,09	1,03	555,3	6,29	17,96	
pc= 45/113	-15	5	975,1	3330	839,2	1,49	5,07	1,28	656,2	6,98	26,64	
return gas temp.	-9,4	15	1236,5	4223	1064,1	1,71	5,83	1,47	724,5	7,47	34,08	
RGT= 32/90	-3,9	25	1547,0	5283	1331,3	1,94	6,64	1,67	795,7	8,00	43,11	
liquid temp	0	32	1796,0	6134	1545,7	2,12	7,23	1,82	848,4	8,41	50,49	
Tliq= 45/113	7,2	45	2334,0	7971	2008,7	2,44	8,35	2,10	954,8	9,26	66,93	
[°C / °F]	-25	-13	458,8	1567	394,9	0,88	3,02	0,76	519,1	5,94	14,34	
cond. pressure	-23	-10	502,3	1716	432,3	0,92	3,14	0,79	547,0	6,15	15,73	
pc= 55/131	-15	5	764,4	2610	657,8	1,12	3,83	0,97	681,4	7,13	24,24	
return gas temp	-9,4	15	985,9	3367	848,5	1,28	4,38	1,10	768,8	7,76	31,60	
RGT= 32/90	-3,9	25	1250,4	4270	1076,1	1,46	4,99	1,26	856,5	8,40	40,58	
liquid temp	0	32	1463,7	4999	1259,7	1,59	5,44	1,37	919,3	8,85	48,00	
Tliq= 55/131	7,2	45	1927,4	6582	1658,8	1,85	6,32	1,59	1041,0	9,75	64,69	



SC Compressors

(External Protector)

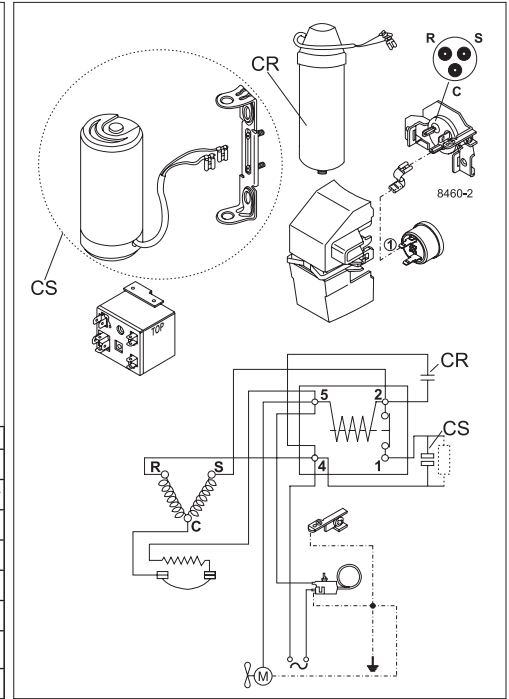
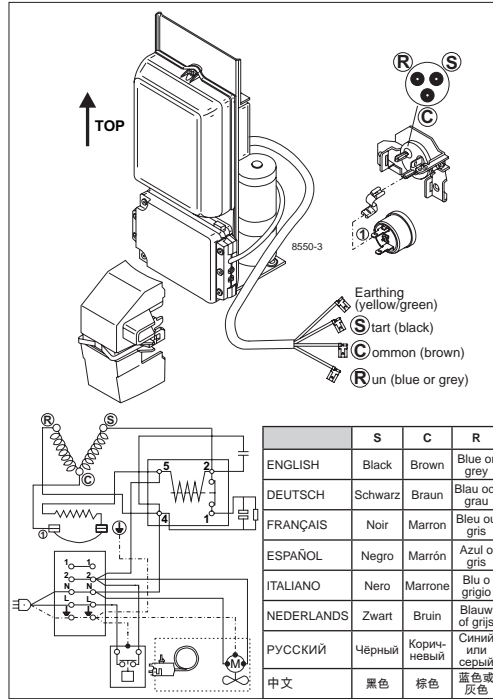
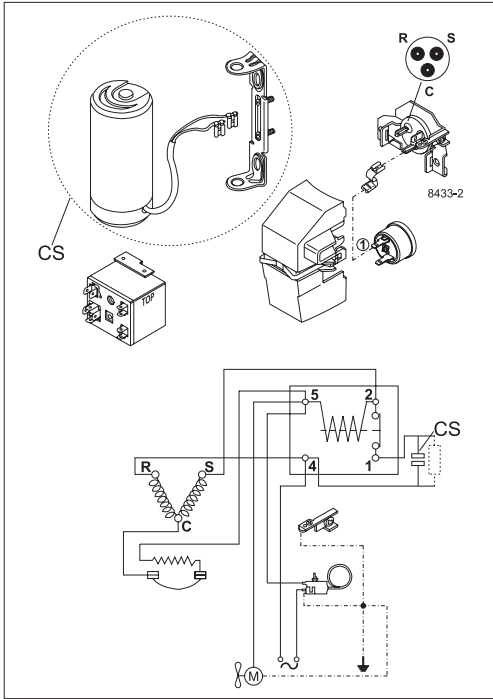



SC Compressors (External Protector)



Service/Repair – R290

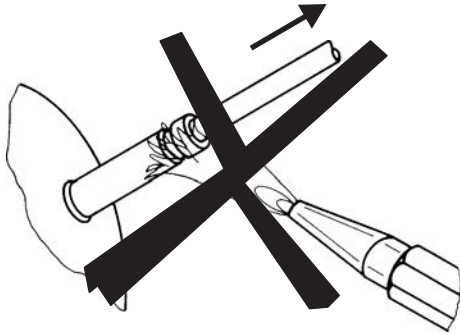

8545



Secop accepts no responsibility for possible errors in catalogs, brochures, and other printed material. Secop reserves the right to alter its products without notice. This also applies to products already on order provided that such alterations can be made without subsequent changes being necessary to specifications already agreed. All trademarks in this material are the property of the respective companies. Secop and the Secop logotype are trademarks of Secop GmbH. All rights reserved. www.secop.com