

Single Pack SC21G 220-240V 50Hz / 208-230V 60Hz CSCR

Codice Imballo Singolo: **195B4537**

Posizione	Titolo	Codice	Quantità
1	Compressor SC21G	104G8140	1
2	SC starting device (650mm)	117-7032	1
3	Cord relief	103N1004	1
4	Cover	103N2009	1
5	Bolt joint for one compressor M6 ø16mm	118-1917	1

Secop GmbH • Lise-Meitner-Straße 29 • 24941 Flensburg, Germany • Tel: +49 46149410 • www.secop.com

Secop non si assume alcuna responsabilità per eventuali errori presenti in cataloghi, brochure e altro materiale stampato. Secop si riserva il diritto di modificare i propri prodotti senza preavviso. Ciò vale anche per i prodotti già ordinati, a condizione che tali modifiche possano essere apportate senza che siano necessarie modifiche successive alle specifiche già concordate. Tutti i marchi presenti in questo materiale sono di proprietà delle rispettive aziende. Secop e il logo Secop sono marchi di Secop GmbH. Tutti i diritti sono riservati.

Model

Designation	SC21G	220-240V/50Hz 1~ 208-230V/60Hz 1~	Sales code:	104G8140
-------------	--------------	--	-------------	-----------------

Compressor design

Oil type	Polyolester	Refrigerant(s)	R134a, R513A
Oil viscosity	22cST	Displacement	20,95cm ³ / 1,28cu.in
Oil quantity	553cm ³ / 18,7fl.oz	Compressors on pallet	80
Refr. charge - tech. limit	1300g / 45,9oz		
Free gas volume comp.	1460cm ³ / 49,4fl.oz		
Weight	13,6kg / 30lbs		
Motor protection	1# internal		
Winding resistance main	3,5Ω (at 25°C)		
Winding resistance aux	13Ω (at 25°C)		
Max. winding temp.	125°C / 257°F		
Max. discharge temp.	130°C / 266°F		



General - Configurations with SC21G

	Conf. 1	Conf. 2	Conf. 3	Conf. 4
Motorconfiguration	CSCR	CSCR	CSCR	CSCR
Power supply (nominal)	220-240V/50Hz	208-230V/60Hz	220-240V/50Hz	208-230V/60Hz
Number of phases	1	1	1	1
Voltage range	187-254V	198-254V	187-254V	198-253V
Approvals	VDE, CCC, EAC	CCC, EAC, UL	VDE, CCC	CCC, UL
Starting torque	HST	HST	HST	HST
Note	- / -			

Applications with SC21G

	Conf. 1	Conf. 2	Conf. 3	Conf. 4
Refrigerant	R134a	R134a	R513A	R513A
Application	LBP+MBP+HBP	LBP	LBP+MBP+HBP	LBP
System cooling	fan 3m/s	fan 3m/s	fan 3m/s	fan 3m/s
Hot gas defrost	OK	OK	OK	OK
Long interval pull down	OK	OK	OK	OK

Electrical data - Configurations with SC21G

	Conf. 1	Conf. 2	Conf. 3	Conf. 4
Starting device type	relay	relay	relay	relay
Run capacitor	10μF	10μF	10μF	10μF
Start capacitor	80μF	80μF	80μF	80μF
LRA (locked rotor amps / 4s/ U(N))	22A	22A	22A	22A
RLA (rated load amps / 1s/ U(N))	3,9A	3,9A	3,9A	3,9A
Cut in current (U(N))	22A	22A	22A	22A

Model

Designation	SC21G	220-240V/50Hz 1~ 208-230V/60Hz 1~	Sales code:	104G8140
-------------	--------------	--	-------------	-----------------

Compressor dimensions

Housing	A Height	219mm / 8,62in
	B Height	213mm / 8,39in
	C Length shell	218mm / 8,58in
	D Length w. cover	255mm / 10,04in
	E Width	151mm / 5,94in

Connectors	Suction		Discharge		Process	
	X		Y		Z	
Diameter [mm]	øi 10,11-10,29		øi 6,11-6,29		øi 6,11-6,29	
(i:inside, o:outside) [in]	øi 0,4-0,41		øi 0,24-0,25		øi 0,24-0,25	
Material	copper		copper		copper	
Horizontal angle ±2°	37°		37°		143°	
Vertical angle ±2°	30°		0°		150°	
Position l/h/w [mm]	107/193/55		115/110/63		-107/193/55	
[in]	4,2/7,6/2,2		4,5/4,3/2,5		-4,2/7,6/2,2	
Straight tube l.	[mm]		12		12	
	[in]		0,5		0,5	

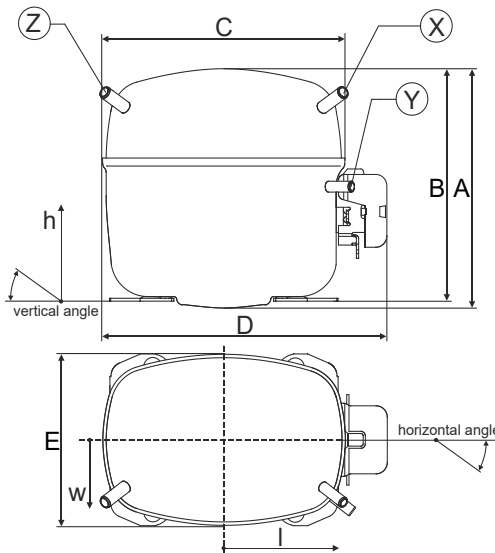

Compressor fixation

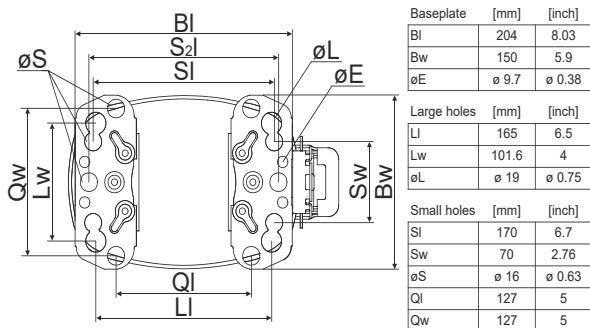

Bolt joint

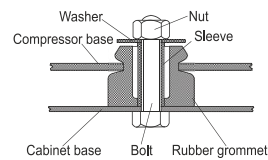

Snap-on

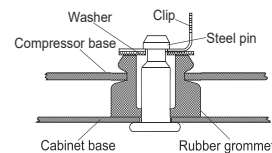

Mounting accessories	one comp.	multi pack
Bolt joint M6 ø16mm	118-1917	118-1918
Bolt joint ø1/4" ø16mm	118-1946	
Bolt joint ø1/4" ø19mm	118-1949	
Snap-on ø7,3 ø16mm	118-1947	118-1919

Application notes

Provision for PE Grounding is located at the PE Stamp on the compressor

Model

Designation **SC21G** **220-240V/50Hz** Conf. 1 Sales code: **104G8140**

Configuration

Motorconfiguration **CSCR**
 Power supply (nominal) **220-240V/50Hz 1~**
 Refrigerant **R134a**
 Application **LBP+MBP+HBP**
 Voltage range **187-254V**
 Starting torque **HST**
 Approvals **VDE**
CCC
EAC

Electrical accessories / wiring diagram

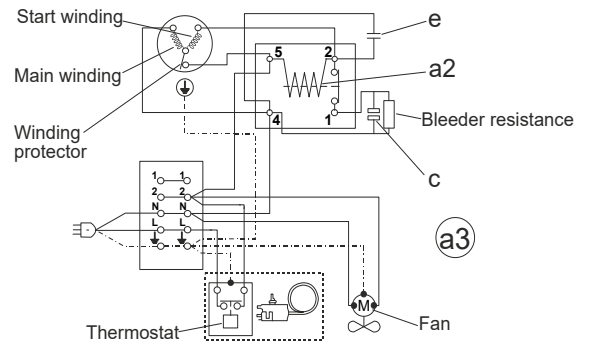
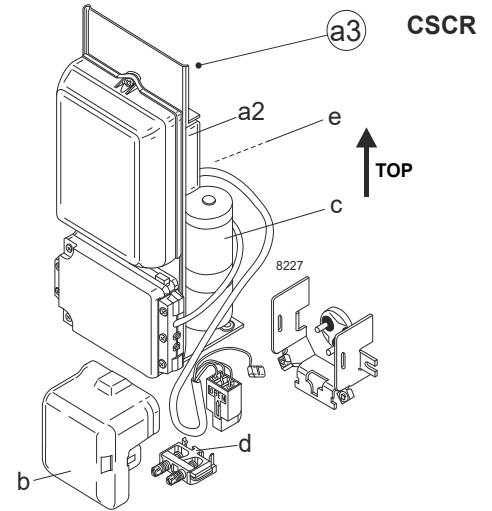

Ambient/ machine room temperatures minimum /maximum

Ambient temperature range: **10 - 43°C / 50 - 110°F**
 Machine room temperature range: **10 - 48°C / 50 - 119°F**
 Compressor cooling: **fan 3m/s**

Operation pressure range

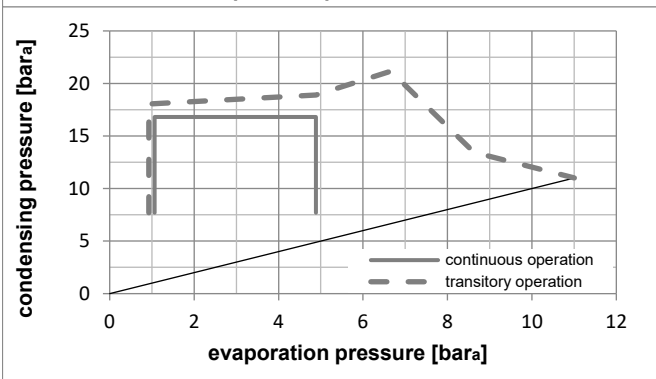
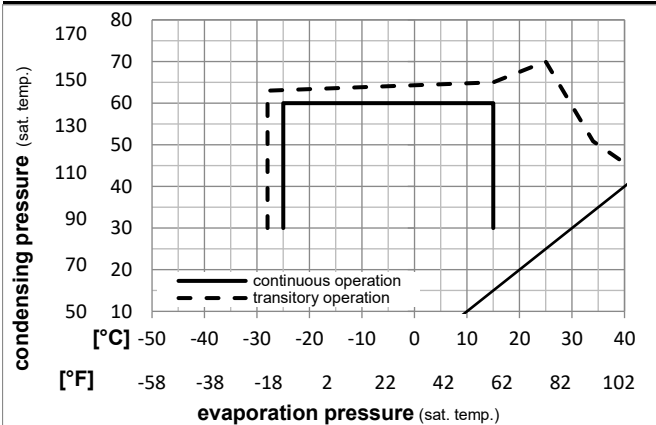

Components

a3	SC starter kit (550mm)	117-7029
b	plastic cover	103N2009
d	cord relief	103N1004

Alternative components

a3	SC starter kit (650mm)	117-7032
a3	SC starter kit (1000mm)	117-7041
a2	potential relay (RVA 4H3R341)	117-7427
c	start capacitor (80µF)	117U5373
e	run capacitor (10µF, 6.3mm)	117-7112

Model

Designation **SC21G** **220-240V/50Hz** Conf. 1 Sales code: **104G8140**

Optimization + standard conditions

R134a, 220V/50Hz, CSCR, fan 3m/s, VDE, CCC, EAC

	Evaporating pressure (saturation temperature)				Cooling capacity			COP	EER	P1	Power consumption		ASHRAE LBP	
	pe	pc	RGT	Tliq	[W]	[Btu/h]	[kcal/h]				I	m		
	[°C]	[°F]	[°C]	[°F]	[W]	[Btu/h]	[kcal/h]	[W/W]	[Btu/Wh]	[kcal/Wh]	[W]	[A]	[kg/h]	
	-23	54	32	32	460,1	1571	396,0	1,22	4,18	1,05	375,7	2,34	8,93	ASHRAE LBP
	-10	130	90	90										
	-25	55	32	55	332,7	1136	286,4	0,96	3,26	0,82	348,2	2,28	7,96	cecomaf LBP
	-13	131	90	131										
	-35	40	20	40	222,2	759	191,2	0,88	2,99	0,75	253,6	1,96	4,87	EN12900 LBP
	-31	104	68	104										
	-7	54	35	46	1040,5	3553	895,5	1,68	5,75	1,45	617,9	3,14	22,70	ASHRAE MBP
	20	130	95	115										
	-10	55	32	55	792,6	2707	682,1	1,39	4,75	1,20	569,4	2,96	19,16	cecomaf MBP
	14	131	90	131										
	-10	45	20	45	931,8	3182	801,9	1,63	5,58	1,41	570,2	2,87	21,81	EN12900 MBP
	14	113	68	113										

Performance tables

R134a, 220V/50Hz, CSCR, fan 3m/s, VDE, CCC, EAC

	pe		Cooling capacity			COP	EER		P1	I	m
	[°C]	[°F]	[W]	[Btu/h]	[kcal/h]		[Btu/Wh]	[kcal/Wh]			
[°C / °F]	-25	-13	420,9	1438	362,3	1,11	3,80	0,96	378,0	2,26	9,12
cond. pressure	-20	-4	570,4	1948	490,9	1,29	4,40	1,11	442,9	2,44	12,39
pc= 45/113	-10	14	966,8	3302	832,0	1,70	5,79	1,46	570,2	2,87	21,16
return gas temp.	-5	23	1215,3	4150	1045,9	1,93	6,60	1,66	629,0	3,12	26,72
RGT= 32/90	0	32	1498,4	5117	1289,5	2,20	7,50	1,89	682,2	3,39	33,14
liquid temp	5	41	1816,9	6205	1563,6	2,50	8,52	2,15	727,9	3,68	40,45
Tliq= 45/113	15	59	2563,1	8754	2205,8	3,25	11,08	2,79	789,8	4,34	58,06
[°C / °F]	-25	-13	332,7	1136	286,4	0,96	3,26	0,82	348,2	2,28	7,96
cond. pressure	-20	-4	453,1	1547	389,9	1,07	3,67	0,92	421,7	2,48	10,87
pc= 55/131	-10	14	792,6	2707	682,1	1,39	4,75	1,20	569,4	2,96	19,16
return gas temp	-5	23	1013,3	3461	872,0	1,58	5,41	1,36	640,0	3,24	24,63
RGT= 32/90	0	32	1269,0	4334	1092,1	1,80	6,14	1,55	705,9	3,54	31,04
liquid temp	5	41	1560,5	5329	1343,0	2,04	6,96	1,75	765,4	3,87	38,45
Tliq= 55/131	15	59	2254,0	7698	1939,8	2,63	8,97	2,26	858,1	4,60	56,61

Model

Designation	SC21G	208-230V/60Hz	Conf. 2	Sales code:	104G8140
-------------	--------------	----------------------	----------------	-------------	-----------------

Configuration

Motorconfiguration	CSCR
Power supply (nominal)	208-230V/60Hz 1~
Refrigerant	R134a
Application	LBP
Voltage range	198-254V
Starting torque	HST
Approvals	CCC
	EAC
	UL

Electrical accessories / wiring diagram

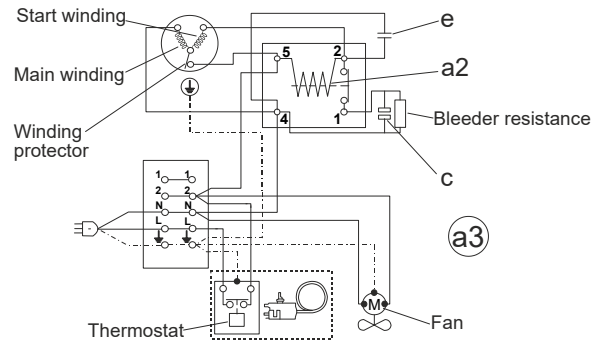
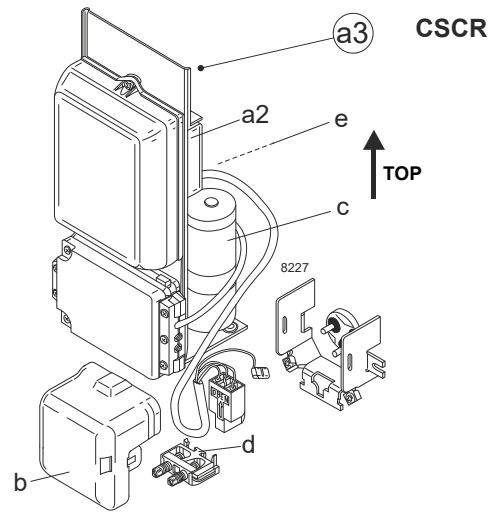

Ambient/ machine room temperatures minimum /maximum

Ambient temperature range:	10 - 43°C / 50 - 110°F
Machine room temperature range:	10 - 48°C / 50 - 119°F
Compressor cooling:	fan 3m/s

Operation pressure range

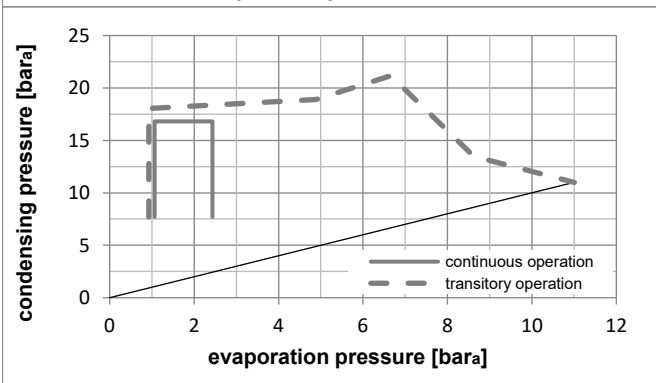
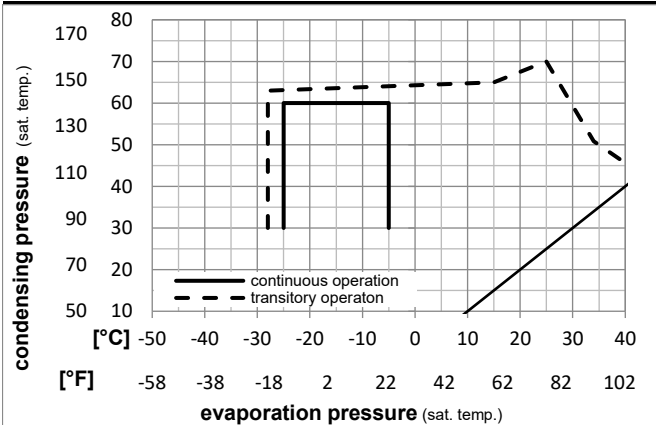

Components

a3	SC starter kit (550mm)	117-7029
b	plastic cover	103N2009
d	cord relief	103N1004

Alternative components

a3	SC starter kit (650mm)	117-7032
a3	SC starter kit (1000mm)	117-7041
a2	potential relay (RVA 4H3R341)	117-7427
c	start capacitor (80µF)	117U5373
e	run capacitor (10µF, 6.3mm)	117-7112

Model

Designation **SC21G** **208-230V/60Hz** Conf. 2 Sales code: **104G8140**

Optimization + standard conditions

R134a, 230V/60Hz, CSCR, fan 3m/s, CCC, EAC, UL

	Evaporating pressure (saturation temperature)				Cooling capacity			COP	EER	P1	Power consumption		Ref. mass flow ṁ	
	pe	pc	RGT	Tliq	[W]	[Btu/h]	[kcal/h]				I	[A]		
	[°C]	[°F]	[°C]	[°F]	[W]	[Btu/h]	[kcal/h]	[W/W]	[Btu/Wh]	[kcal/Wh]	[W]	[A]	[kg/h]	
	-23	54	32	32	443,9	1516	382,0	1,07	3,67	0,92	413,2	1,90	8,62	ASHRAE LBP
	-10	130	90	90										
	-25	55	32	55	303,4	1036	261,1	0,80	2,74	0,69	378,6	1,77	7,25	cecomaf LBP
	-13	131	90	131										
	-35	40	20	40	231,4	790	199,1	0,82	2,79	0,70	283,4	1,29	5,08	EN12900 LBP
	-31	104	68	104										
	-7	54	35	46	1165,8	3981	1003,3	1,67	5,69	1,43	700,0	3,09	25,43	ASHRAE MBP
	20	130	95	115										
	-10	55	32	55	880,1	3006	757,4	1,36	4,66	1,17	645,1	2,86	21,28	cecomaf MBP
	14	131	90	131										
	-10	45	20	45	1000,0	3415	860,6	1,61	5,49	1,38	622,6	2,73	23,41	EN12900 MBP
	14	113	68	113										

Performance tables

R134a, 230V/60Hz, CSCR, fan 3m/s, CCC, EAC, UL

	pe		Cooling capacity			COP	EER		P1	I	m
	[°C]	[°F]	[W]	[Btu/h]	[kcal/h]		[Btu/Wh]	[kcal/Wh]			
[°C / °F]	-25	-13	439,8	1502	378,5	1,07	3,64	0,92	412,9	1,84	9,53
cond. pressure	-23	-10	493,1	1684	424,3	1,13	3,85	0,97	437,2	1,94	10,69
pc= 45/113	-20	-4	606,1	2070	521,6	1,25	4,28	1,08	483,6	2,15	13,17
return gas temp.	-18	0	688,9	2353	592,9	1,34	4,58	1,15	514,2	2,28	14,99
RGT= 32/90	-15	5	803,8	2745	691,7	1,45	4,96	1,25	553,0	2,44	17,52
liquid temp	-10	14	1037,5	3543	892,9	1,67	5,69	1,43	622,6	2,73	22,71
Tliq= 45/113	-5	23	1311,7	4480	1128,9	1,89	6,46	1,63	693,8	3,01	28,84
[°C / °F]	-25	-13	303,4	1036	261,1	0,80	2,74	0,69	378,6	1,77	7,25
cond. pressure	-23	-10	354,9	1212	305,4	0,86	2,95	0,74	410,9	1,90	8,49
pc= 55/131	-20	-4	464,0	1585	399,3	0,98	3,36	0,85	471,7	2,14	11,13
return gas temp	-18	0	543,9	1858	468,1	1,06	3,63	0,92	511,1	2,30	13,07
RGT= 32/90	-15	5	654,7	2236	563,4	1,17	3,99	1,01	560,1	2,51	15,76
liquid temp	-10	14	880,1	3006	757,4	1,36	4,66	1,17	645,1	2,86	21,28
Tliq= 55/131	-5	23	1144,6	3909	985,1	1,57	5,37	1,35	728,2	3,21	27,82

Model

Designation	SC21G	220-240V/50Hz	Conf. 3	Sales code:	104G8140
-------------	--------------	----------------------	----------------	-------------	-----------------

Configuration

Motorconfiguration	CSCR
Power supply (nominal)	220-240V/50Hz 1~
Refrigerant	R513A
Application	LBP+MBP+HBP
Voltage range	187-254V
Starting torque	HST
Approvals	VDE CCC

Electrical accessories / wiring diagram

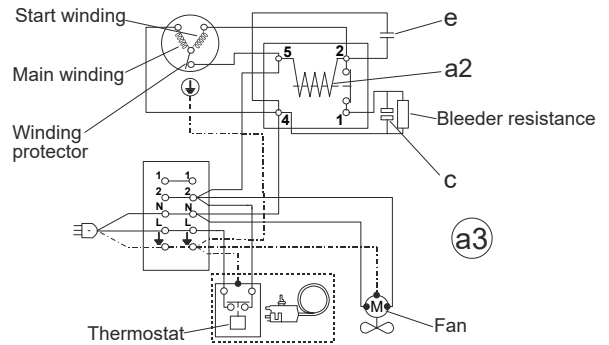
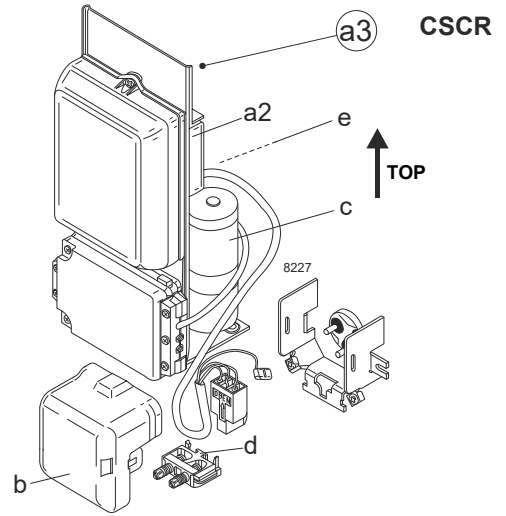

Ambient/ machine room temperatures minimum /maximum

Ambient temperature range:	10 - 43°C / 50 - 110°F
Machine room temperature range:	10 - 48°C / 50 - 119°F
Compressor cooling:	fan 3m/s

Operation pressure range

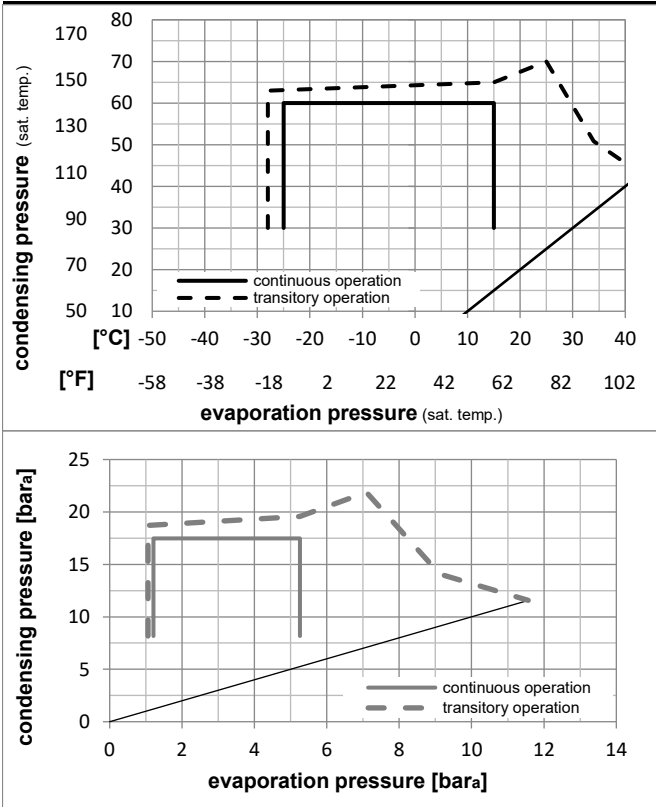

Components

a3	SC starter kit (550mm)	117-7029
b	plastic cover	103N2009
d	cord relief	103N1004

Alternative components

a3	SC starter kit (650mm)	117-7032
a3	SC starter kit (1000mm)	117-7041
a2	potential relay (RVA 4H3R341)	117-7427
c	start capacitor (80µF)	117U5373
e	run capacitor (10µF, 6.3mm)	117-7112

Model

Designation **SC21G** **220-240V/50Hz** Conf. 3 Sales code: **104G8140**

Optimization + standard conditions

R513A, 220V/50Hz, CSCR, fan 3m/s, VDE, CCC

	Evaporating pressure (saturation temperature)				Cooling capacity			COP	EER	P1	Power consumption		Ref. mass flow ṁ	
	pe	pc	RGT	Tliq	[W]	[Btu/h]	[kcal/h]				I	[A]		
[°C]	-23	54	32	32	512,0	1749	440,6	1,25	4,26	1,07	410,5	2,40	11,02	ASHRAE LBP
[°F]	-10	130	90	90										
[°C]	-25	55	32	55	360,7	1232	310,4	0,94	3,23	0,81	381,8	2,28	9,88	cecomaf LBP
[°F]	-13	131	90	131										
[°C]	-35	40	20	40	249,6	852	214,8	0,90	3,06	0,77	278,8	1,87	6,17	EN12900 LBP
[°F]	-31	104	68	104										
[°C]	-7	54	35	46	1092,8	3732	940,4	1,66	5,67	1,43	658,3	3,39	26,77	ASHRAE MBP
[°F]	20	130	95	115										
[°C]	-10	55	32	55	823,3	2812	708,5	1,35	4,61	1,16	609,3	3,19	22,76	cecomaf MBP
[°F]	14	131	90	131										
[°C]	-10	45	20	45	974,3	3328	838,5	1,60	5,46	1,38	608,9	3,19	25,82	EN12900 MBP
[°F]	14	113	68	113										

Performance tables

R513A, 220V/50Hz, CSCR, fan 3m/s, VDE, CCC

	pe		Cooling capacity			COP	EER		P1	I	m
	[°C]	[°F]	[W]	[Btu/h]	[kcal/h]		[Btu/Wh]	[kcal/Wh]			
[°C / °F]	-25	-13	460,1	1571	395,9	1,12	3,81	0,96	412,1	2,40	11,21
cond. pressure	-20	-4	614,7	2099	529,0	1,28	4,38	1,10	479,4	2,67	15,02
pc= 45/113	-10	14	1018,9	3480	876,8	1,67	5,71	1,44	608,9	3,19	25,05
return gas temp.	-5	23	1269,5	4335	1092,5	1,90	6,49	1,64	667,7	3,42	31,34
RGT= 32/90	0	32	1553,1	5304	1336,6	2,16	7,37	1,86	720,1	3,63	38,52
liquid temp	5	41	1870,4	6388	1609,7	2,45	8,36	2,11	764,5	3,81	46,65
Tliq= 45/113	15	59	2607,8	8906	2244,3	3,17	10,84	2,73	821,8	4,04	65,98
[°C / °F]	-25	-13	360,7	1232	310,4	0,94	3,23	0,81	381,8	2,28	9,88
cond. pressure	-20	-4	483,1	1650	415,8	1,05	3,60	0,91	458,2	2,59	13,26
pc= 55/131	-10	14	823,3	2812	708,5	1,35	4,61	1,16	609,3	3,19	22,76
return gas temp	-5	23	1042,1	3559	896,8	1,53	5,23	1,32	680,4	3,47	28,95
RGT= 32/90	0	32	1294,2	4420	1113,8	1,73	5,92	1,49	746,2	3,74	36,14
liquid temp	5	41	1580,0	5396	1359,8	1,96	6,70	1,69	804,9	3,97	44,40
Tliq= 55/131	15	59	2255,0	7701	1940,7	2,52	8,61	2,17	894,0	4,33	64,40

Model

Designation	SC21G	208-230V/60Hz	Conf. 4	Sales code:	104G8140
-------------	--------------	----------------------	----------------	-------------	-----------------

Configuration

Motorconfiguration	CSCR
Power supply (nominal)	208-230V/60Hz 1~
Refrigerant	R513A
Application	LBP
Voltage range	198-253V
Starting torque	HST
Approvals	CCC UL

Electrical accessories / wiring diagram

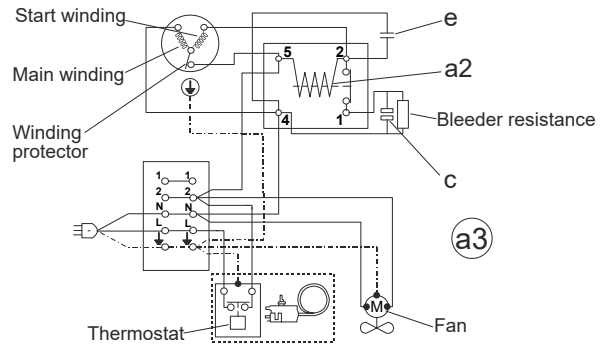
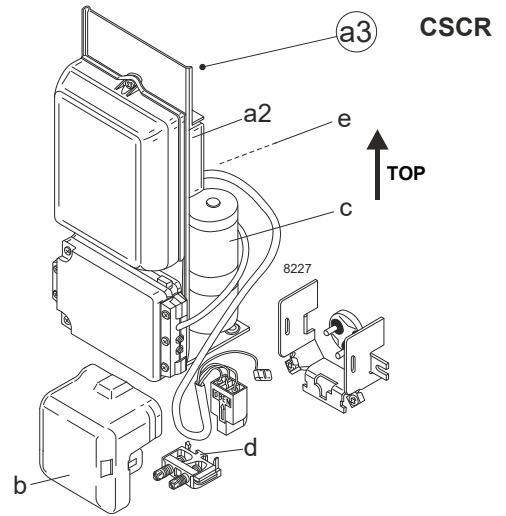

Ambient/ machine room temperatures minimum /maximum

Ambient temperature range:	10 - 43°C / 50 - 110°F
Machine room temperature range:	10 - 48°C / 50 - 119°F
Compressor cooling:	fan 3m/s

Operation pressure range

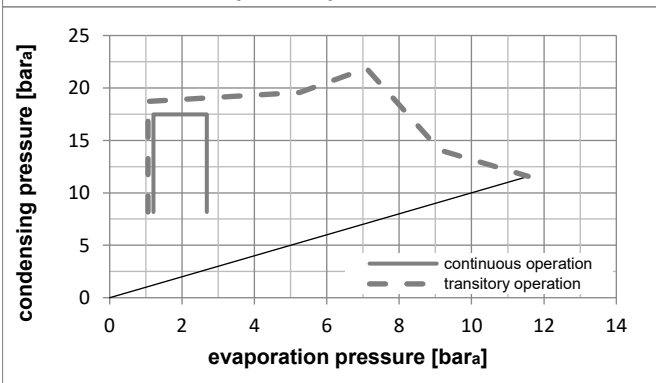
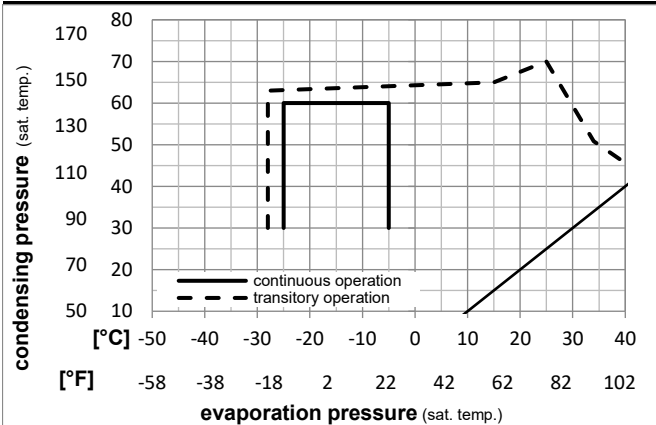

Components

a3	SC starter kit (550mm)	117-7029
b	plastic cover	103N2009
d	cord relief	103N1004

Alternative components

a3	SC starter kit (650mm)	117-7032
a3	SC starter kit (1000mm)	117-7041
a2	potential relay (RVA 4H3R341)	117-7427
c	start capacitor (80µF)	117U5373
e	run capacitor (10µF, 6.3mm)	117-7112

Model

Designation **SC21G** **208-230V/60Hz** Conf. 4 Sales code: **104G8140**

Optimization + standard conditions

R513A, 230V/60Hz, CSCR, fan 3m/s, CCC, UL

	Evaporating pressure (saturation temperature)				Cooling capacity			COP	EER	P1	Power consumption		Ref. mass flow ṁ	
	pe	pc	RGT	Tliq	[W]	[Btu/h]	[kcal/h]				I	[A]		
[°C]	-23	54	32	32	494,1	1687	425,2	1,10	3,75	0,95	449,4	2,09	10,63	ASHRAE LBP
[°F]	-10	130	90	90										
[°C]	-25	55	32	55	329,3	1125	283,4	0,80	2,72	0,69	413,1	1,95	9,02	cecomaf LBP
[°F]	-13	131	90	131										
[°C]	-35	40	20	40	262,1	895	225,5	0,84	2,88	0,72	311,3	1,58	6,48	EN12900 LBP
[°F]	-31	104	68	104										
[°C]	-7	54	35	46	1225,5	4185	1054,7	1,65	5,63	1,42	743,2	3,17	30,02	ASHRAE MBP
[°F]	20	130	95	115										
[°C]	-10	55	32	55	914,8	3124	787,3	1,33	4,54	1,14	687,9	2,97	25,30	cecomaf MBP
[°F]	14	131	90	131										
[°C]	-10	45	20	45	1046,7	3575	900,8	1,58	5,40	1,36	662,6	2,87	27,74	EN12900 MBP
[°F]	14	113	68	113										

Performance tables

R513A, 230V/60Hz, CSCR, fan 3m/s, CCC, UL

	pe		Cooling capacity			COP	EER		P1	I	m
	[°C]	[°F]	[W]	[Btu/h]	[kcal/h]		[Btu/Wh]	[kcal/Wh]			
[°C / °F]	-25	-13	480,8	1642	413,8	1,07	3,66	0,92	448,6	2,08	11,72
cond. pressure	-23	-10	536,3	1832	461,6	1,13	3,87	0,97	473,7	2,18	13,08
pc= 45/113	-20	-4	653,4	2232	562,3	1,25	4,28	1,08	521,5	2,35	15,96
return gas temp.	-18	0	738,8	2523	635,8	1,34	4,56	1,15	552,8	2,47	18,07
RGT= 32/90	-15	5	856,6	2925	737,2	1,45	4,94	1,24	592,3	2,61	20,99
liquid temp	-10	14	1094,5	3738	942,0	1,65	5,64	1,42	662,6	2,87	26,91
Tliq= 45/113	-5	23	1371,6	4684	1180,4	1,87	6,38	1,61	734,0	3,14	33,86
[°C / °F]	-25	-13	329,3	1125	283,4	0,80	2,72	0,69	413,1	1,95	9,02
cond. pressure	-23	-10	382,6	1306	329,2	0,86	2,92	0,74	446,9	2,08	10,48
pc= 55/131	-20	-4	494,6	1689	425,6	0,97	3,31	0,83	510,2	2,31	13,58
return gas temp	-18	0	576,1	1967	495,8	1,05	3,57	0,90	550,9	2,46	15,84
RGT= 32/90	-15	5	688,3	2351	592,4	1,14	3,91	0,99	601,3	2,65	18,96
liquid temp	-10	14	914,8	3124	787,3	1,33	4,54	1,14	687,9	2,97	25,30
Tliq= 55/131	-5	23	1178,4	4025	1014,2	1,53	5,21	1,31	771,8	3,28	32,73

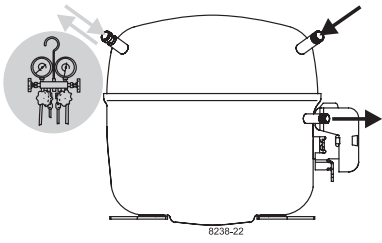

SC Compressors

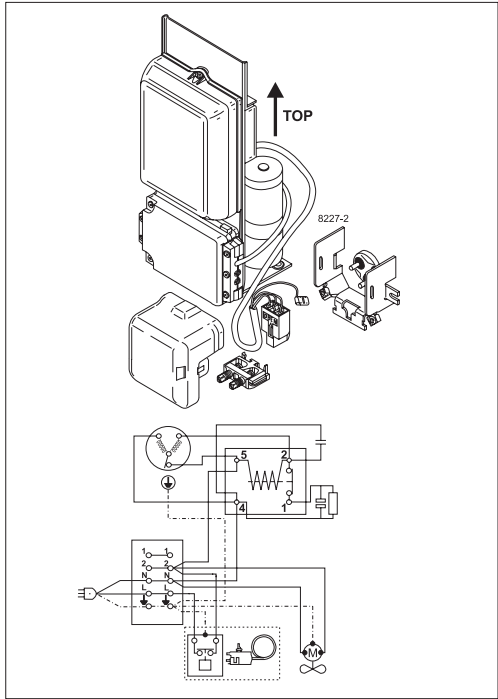
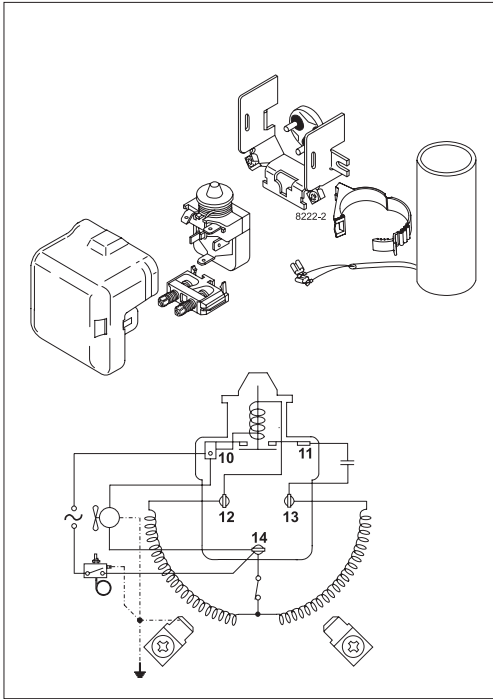
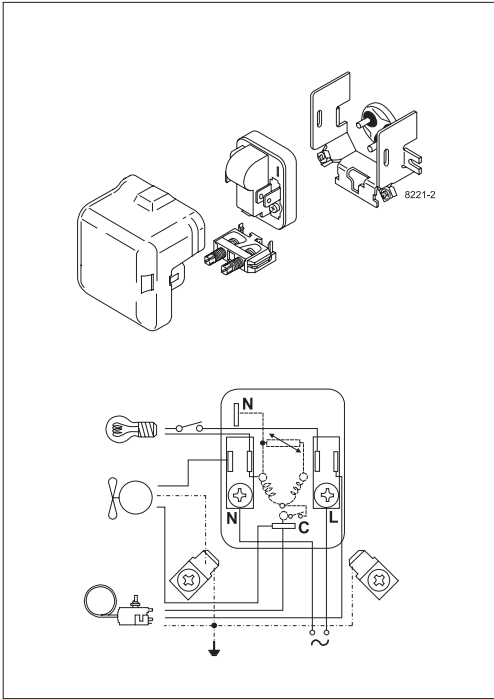



SC Compressors

Service/Repair – R290

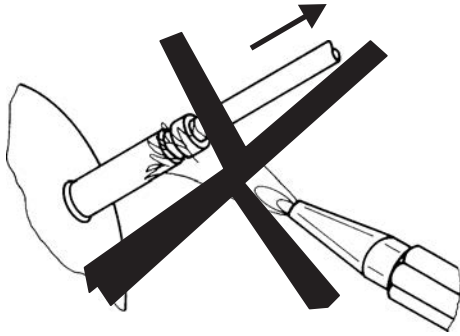

8545



Secop accepts no responsibility for possible errors in catalogs, brochures, and other printed material. Secop reserves the right to alter its products without notice. This also applies to products already on order provided that such alterations can be made without subsequent changes being necessary to specifications already agreed. All trademarks in this material are the property of the respective companies. Secop and the Secop logotype are trademarks of Secop GmbH. All rights reserved. www.secop.com