

Single Pack NLE10CN 115-127V 60Hz CSIR

Codice Imballo Singolo: **195B4546**

Posizione	Titolo	Codice	Quantità
1	Compressor NLE10CN	105H6194	1
2	Starting relay	117U7018	1
3	Starting capacitor (280 μ F 125V, 6.3mm)	117U5025	1
4	Cord relief	103N1010	1
5	Cover	103N2011	1
6	Bolt joint for one compressor M6 \varnothing 16mm	118-1917	1

Secop GmbH • Lise-Meitner-Straße 29 • 24941 Flensburg, Germany • Tel: +49 46149410 • www.secop.com

Secop non si assume alcuna responsabilità per eventuali errori presenti in cataloghi, brochure e altro materiale stampato. Secop si riserva il diritto di modificare i propri prodotti senza preavviso. Ciò vale anche per i prodotti già ordinati, a condizione che tali modifiche possano essere apportate senza che siano necessarie modifiche successive alle specifiche già concordate. Tutti i marchi presenti in questo materiale sono di proprietà delle rispettive aziende. Secop e il logo Secop sono marchi di Secop GmbH. Tutti i diritti sono riservati.

Model

Designation	NLE10CN	115-127V/60Hz 1~	Sales code:	105H6194
-------------	----------------	------------------	-------------	-----------------

Compressor design

Oil type	Polyolester	Refrigerant(s)	R290
Oil viscosity	32cSt	Displacement	10,09cm ³ / 0,62cu.in
Oil quantity	268cm ³ / 9,1fl.oz	Compressors on pallet	80
Refr. charge - tech. limit	400g / 14,1oz		
Free gas volume comp.	2360cm ³ / 79,8fl.oz		
Weight	10,9kg / 24lbs		
Motor protection	1# internal		
Winding resistance main	1,56Ω (at 25°C)		
Winding resistance aux	4,4Ω (at 25°C)		
Max. winding temp.	125°C / 257°F		
Max. discharge temp.	120°C / 248°F		



General - Configurations with NLE10CN

	Conf. 1	Conf. 2	Conf. 3
Motorconfiguration	CSIR	RSIR	RSCR
Power supply (nominal)	115V/60Hz	115V/60Hz	115V/60Hz
Number of phases	1	1	1
Voltage range	103-127V	103-127V	103-127V
Approvals	UL, CCC	UL, CCC	UL, CCC
Starting torque	HST	LST	LST
Note	- / -		

Applications with NLE10CN

	Conf. 1	Conf. 2	Conf. 3
Refrigerant	R290	R290	R290
Application	LBP+MBP	LBP+MBP	LBP+MBP
System cooling	fan 3m/s	fan 3m/s	fan 3m/s
Hot gas defrost	OK	OK	OK
Long interval pull down	OK	OK	OK

Electrical data - Configurations with NLE10CN

	Conf. 1	Conf. 2	Conf. 3
Starting device type	relay	PTC	PTC
Run capacitor	-/-	-/-	15μF
Start capacitor	280μF	-/-	-/-
LRA (locked rotor amps / 4s/ U(N))	34,53A	29,18A	29,18A
RLA (rated load amps / 1s/ U(N))	5,6A	5,6A	5,6A
Cut in current (U(N))	34,53A	38,64A	38,64A

Model

Designation

NLE10CN

115-127V/60Hz 1~

Sales code:

105H6194

Compressor dimensions

Housing	A Height	203mm / 7,99in
	B Height	197mm / 7,76in
	C Length shell	205mm / 8,07in
	D Length w. cover	254mm / 10in
	E Width	166mm / 6,54in

Connectors		Suction	Discharge	Process
		X	Y	Z
Diameter	[mm]	øi 8,11-8,29	øi 6,41-6,59	øi 6,41-6,59
(i:inside, o:outside)	[in]	øi 0,32-0,33	øi 0,25-0,26	øi 0,25-0,26
Material		copper	copper	copper
Horizontal angle	±2°	0°	0°	0°
Vertical angle	±2°	15°	21°	155°
Position l/h/w	[mm]	132/69/57	94/102/81	-109/94/72
	[in]	5,2/2,7/2,2	3,7/4/3,2	-4,3/3,7/2,8
Straight tube l.	[mm]	12	12	12
	[in]	0,5	0,5	0,5

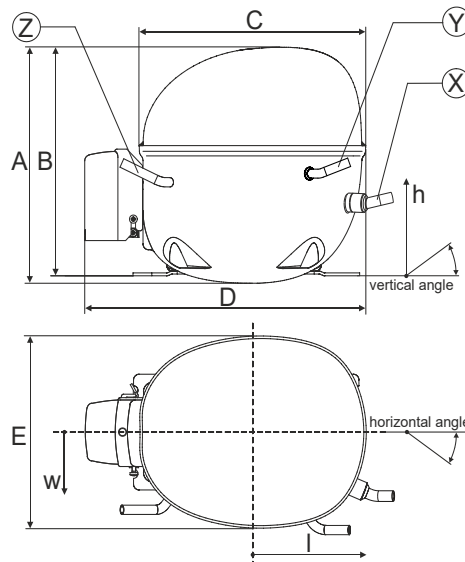

Compressor fixation



Bolt joint



Snap-on

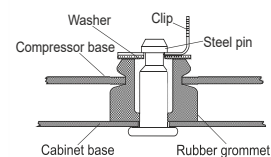

Mounting accessories

Mounting accessories	one comp.	multi pack
Bolt joint M6 ø16mm	118-1917	118-1918
Bolt joint ø1/4" ø16mm	118-1946	
Bolt joint ø1/4" ø19mm	118-1949	
Snap-on ø7,3 ø16mm	118-1947	118-1919

#NV

#NV

Provision for PE Grounding is located at the PE Stamp on the compressor

Model

Designation	NLE10CN	115V/60Hz	Conf. 1	Sales code:	105H6194
-------------	----------------	------------------	----------------	-------------	-----------------

Configuration

Motorconfiguration	CSIR	
Power supply (nominal)	115V/60Hz 1~	
Refrigerant	R290	
Application	LBP+MBP	
Voltage range	103-127V	
Starting torque	HST	
Approvals	UL	SA3693
	CCC	

Electrical accessories / wiring diagram



Ambient/ machine room temperatures minimum /maximum

Ambient temperature range:	10 - 43°C / 50 - 110°F
Machine room temperature range:	10 - 48°C / 50 - 119°F
Compressor cooling:	fan 3m/s

Operation pressure range

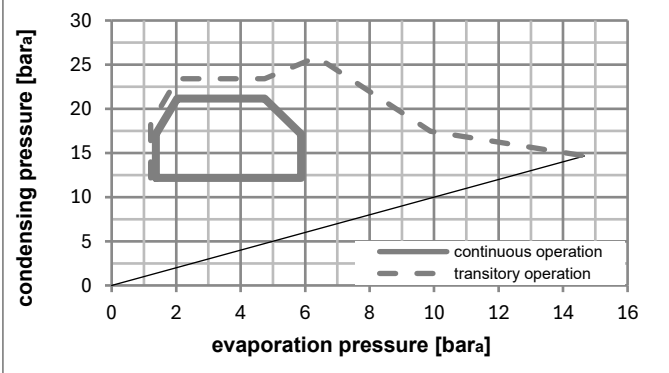
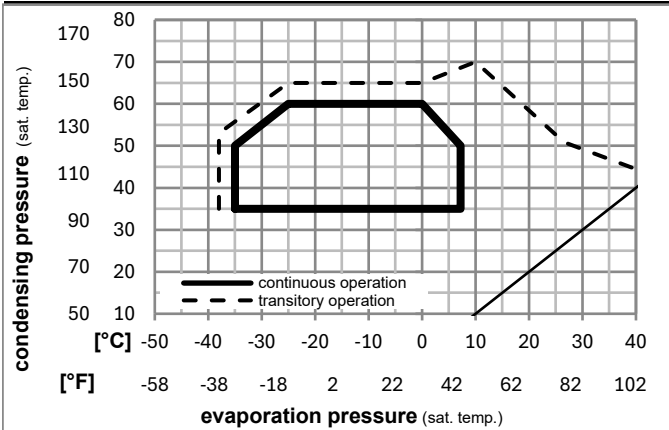

Components

a2	current relay	117U7018
c	start capacitor (280µF)	117U5025
b	plastic cover	103N2011
d	cord relief	103N1010

Model

Designation **NLE10CN** **115V/60Hz** Conf. 1 Sales code: **105H6194**

Optimization + standard conditions

R290, 115V/60Hz, CSIR, fan 3m/s, UL, CCC

		Evaporating pressure (saturation temperature)				Condensing pressure (saturation temperature)			Return gas temp.		Liquid temp.		Cooling capacity			COP		EER		Power consumption			Ref. mass flow
		pe	pc	RGT	Tliq	[W]	[Btu/h]	[kcal/h]	[W/W]	[Btu/Wh]	[kcal/Wh]	P1	I	m	[W]	[A]	[kg/h]						
[°C]	[°F]																						
-23	-10	54	130	32	90	607,0	2073	522,4	1,52	5,20	1,31	399,0	5,18	6,15					ASHRAE LBP				
-25	-13	55	131	32	90	456,4	1559	392,8	1,17	4,00	1,01	389,8	5,13	5,68					cecomaf LBP				
-35	-31	40	104	20	68	361,5	1235	311,1	1,26	4,31	1,09	286,2	4,52	4,13					EN12900 LBP				
-7	20	54	130	35	95	1069,4	3652	920,3	2,05	6,99	1,76	522,8	5,95	12,20					ASHRAE MBP				
-10	14	55	131	32	90	854,1	2917	735,1	1,70	5,80	1,46	502,8	5,84	10,80					cecomaf MBP				
-10	14	45	113	20	68	934,1	3190	803,9	2,04	6,95	1,75	458,8	5,48	11,47					EN12900 MBP				

Performance tables

R290, 115V/60Hz, CSIR, fan 3m/s, UL, CCC

	pe		Cooling capacity			COP		EER		P1	I	m
	[°C]	[°F]	[W]	[Btu/h]	[kcal/h]	[W/W]	[Btu/Wh]	[kcal/Wh]	[W]	[A]	[kg/h]	
[°C / °F]	-35	-31	339,2	1159	292,0	1,18	4,02	1,01	288,4	4,52	3,80	
cond. pressure	-23	-10	575,9	1967	495,6	1,55	5,29	1,33	371,9	5,00	6,50	
pc= 45/113	-15	5	807,4	2757	694,8	1,89	6,47	1,63	426,2	5,30	9,19	
return gas temp.	-9	15	992,1	3388	853,8	2,15	7,33	1,85	462,5	5,50	11,36	
RGT= 32/90	-4	25	1202,1	4105	1034,5	2,40	8,20	2,07	500,4	5,71	13,86	
liquid temp	0	32	1364,5	4660	1174,3	2,58	8,82	2,22	528,6	5,87	15,83	
Tliq= 45/113	7,2	45	1701,0	5809	1463,9	2,90	9,91	2,50	586,3	6,20	19,99	
[°C / °F]	-35	-31	281,6	962	242,4	0,93	3,16	0,80	304,4	4,62	3,48	
cond. pressure	-23	-10	492,3	1681	423,7	1,22	4,17	1,05	402,9	5,21	6,14	
pc= 55/131	-15	5	702,7	2400	604,7	1,51	5,15	1,30	465,9	5,60	8,83	
return gas temp	-9	15	872,1	2978	750,6	1,72	5,88	1,48	507,0	5,86	11,04	
RGT= 32/90	-4	25	1065,9	3640	917,3	1,94	6,63	1,67	548,9	6,15	13,60	
liquid temp	0	32	1216,5	4155	1046,9	2,10	7,17	1,81	579,5	6,36	15,62	
Tliq= 55/131	7,2	45	1529,7	5224	1316,5	2,39	8,15	2,05	640,6	6,80	19,93	

Model

Designation	NLE10CN	115V/60Hz	Conf. 2	Sales code:	105H6194
-------------	----------------	------------------	----------------	-------------	-----------------

Configuration

Motorconfiguration	RSIR	
Power supply (nominal)	115V/60Hz 1~	
Refrigerant	R290	
Application	LBP+MBP	
Voltage range	103-127V	
Starting torque	LST	
Approvals	UL	SA3693
	CCC	

Electrical accessories / wiring diagram

RSIR

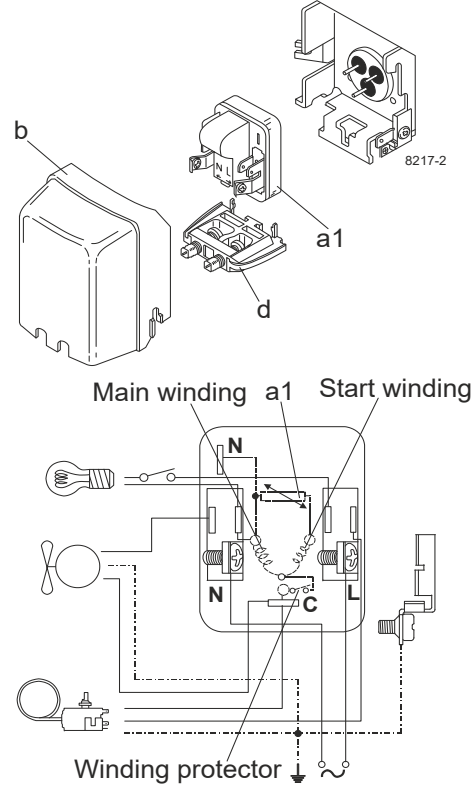

Ambient/ machine room temperatures minimum /maximum

Ambient temperature range:	10 - 43°C / 50 - 110°F
Machine room temperature range:	10 - 48°C / 50 - 119°F
Compressor cooling:	fan 3m/s

Operation pressure range

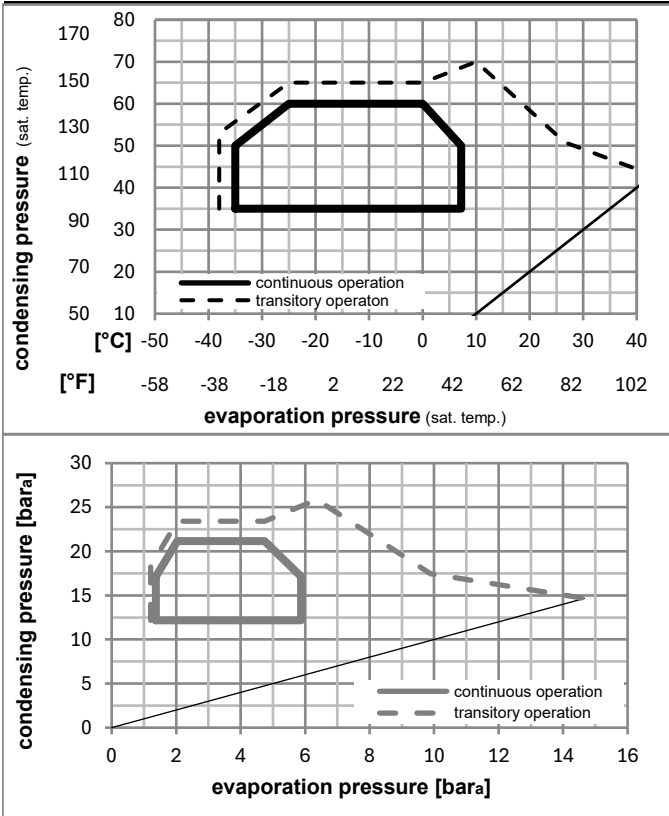

Components

a1	e-PTC starter (115V, 50hm, 6.3mm, 4.8-c)	103N0057
b	plastic cover	103N2011
d	cord relief	103N1010

Alternative components

a1	e-PTC starter	103N0058
b	plastic cover	103N2011
d	cord relief	103N1010

Model

Designation **NLE10CN** **115V/60Hz** Conf. 2 Sales code: **105H6194**

Optimization + standard conditions

R290, 115V/60Hz, RSIR, fan 3m/s, UL, CCC

	Evaporating pressure (saturation temperature)				Cooling capacity			COP	EER			Power consumption			ASHRAE LBP
	pe	pc	RGT	Tliq	[W]	[Btu/h]	[kcal/h]		[W/W]	[Btu/Wh]	[kcal/Wh]	P1	I	m	
[°C]	-23	54	32	32	607,0	2073	522,4	1,52	5,20	1,31	399,0	5,18	6,15		
[°F]	-10	130	90	90											
[°C]	-25	55	32	55	456,4	1559	392,8	1,17	4,00	1,01	389,8	5,13	5,68	cecomaf LBP	
[°F]	-13	131	90	131											
[°C]	-35	40	20	40	361,5	1235	311,1	1,26	4,31	1,09	286,2	4,52	4,13	EN12900 LBP	
[°F]	-31	104	68	104											
[°C]	-7	54	35	46	1069,4	3652	920,3	2,05	6,99	1,76	522,8	5,95	12,20	ASHRAE MBP	
[°F]	20	130	95	115											
[°C]	-10	55	32	55	854,1	2917	735,1	1,70	5,80	1,46	502,8	5,84	10,80	cecomaf MBP	
[°F]	14	131	90	131											
[°C]	-10	45	20	45	934,1	3190	803,9	2,04	6,95	1,75	458,8	5,48	11,47	EN12900 MBP	
[°F]	14	113	68	113											

Performance tables

R290, 115V/60Hz, RSIR, fan 3m/s, UL, CCC

	pe		Cooling capacity			COP	EER		P1	I	m
	[°C]	[°F]	[W]	[Btu/h]	[kcal/h]		[W/W]	[Btu/Wh]			
[°C / °F]	-35	-31	339,2	1159	292,0	1,18	4,02	1,01	288,4	4,52	3,80
cond. pressure	-23	-10	575,9	1967	495,6	1,55	5,29	1,33	371,9	5,00	6,50
pc= 45/113	-15	5	807,4	2757	694,8	1,89	6,47	1,63	426,2	5,30	9,19
return gas temp.	-9	15	992,1	3388	853,8	2,15	7,33	1,85	462,5	5,50	11,36
RGT= 32/90	-4	25	1202,1	4105	1034,5	2,40	8,20	2,07	500,4	5,71	13,86
liquid temp	0	32	1364,5	4660	1174,3	2,58	8,82	2,22	528,6	5,87	15,83
Tliq= 45/113	7,2	45	1701,0	5809	1463,9	2,90	9,91	2,50	586,3	6,20	19,99
[°C / °F]	-35	-31	281,6	962	242,4	0,93	3,16	0,80	304,4	4,62	3,48
cond. pressure	-23	-10	492,3	1681	423,7	1,22	4,17	1,05	402,9	5,21	6,14
pc= 55/131	-15	5	702,7	2400	604,7	1,51	5,15	1,30	465,9	5,60	8,83
return gas temp	-9	15	872,1	2978	750,6	1,72	5,88	1,48	507,0	5,86	11,04
RGT= 32/90	-4	25	1065,9	3640	917,3	1,94	6,63	1,67	548,9	6,15	13,60
liquid temp	0	32	1216,5	4155	1046,9	2,10	7,17	1,81	579,5	6,36	15,62
Tliq= 55/131	7,2	45	1529,7	5224	1316,5	2,39	8,15	2,05	640,6	6,80	19,93

Model

Designation	NLE10CN	115V/60Hz	Conf. 3	Sales code:	105H6194
-------------	----------------	------------------	----------------	-------------	-----------------

Configuration

Motorconfiguration	RSCR	
Power supply (nominal)	115V/60Hz 1~	
Refrigerant	R290	
Application	LBP+MBP	
Voltage range	103-127V	
Starting torque	LST	
Approvals	UL	SA3693
	CCC	

Electrical accessories / wiring diagram

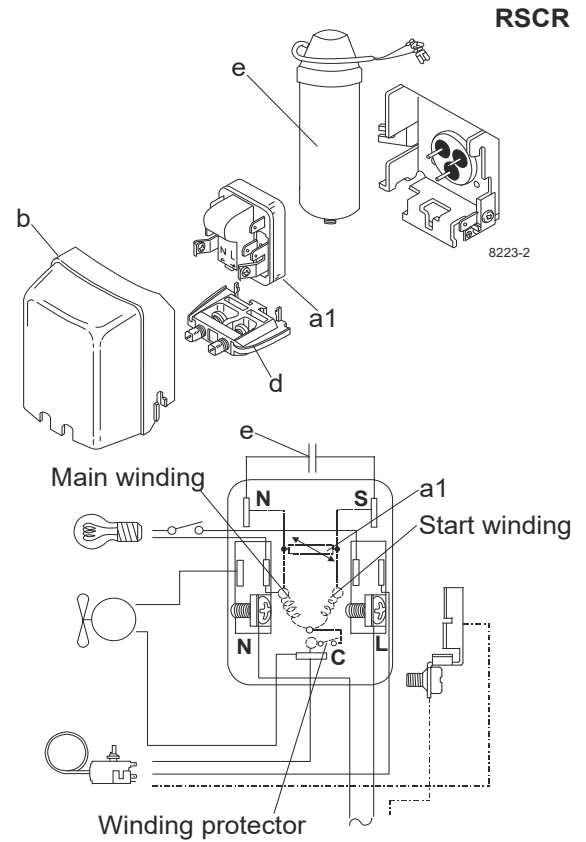

Ambient/ machine room temperatures minimum /maximum

Ambient temperature range:	10 - 43°C / 50 - 110°F
Machine room temperature range:	10 - 48°C / 50 - 119°F
Compressor cooling:	fan 3m/s

Operation pressure range

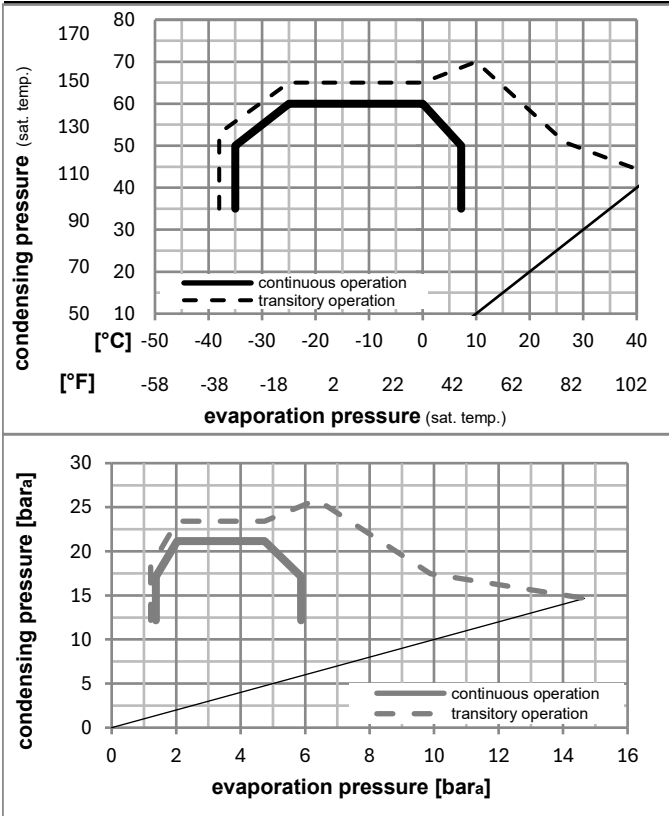

Components

a1	e-PTC starter	103N0058
e	run capacitor (15μF, 6.3mm)	117-7118
b	plastic cover	103N2011
d	cord relief	103N1010
	bracket for run capacitor	117-0300
	screw M4x8mm	117-0301

Alternative components

a1	e-PTC starter (115V, 50Ohm, 6.3mm, 4.8-c)	103N0057
e	run capacitor (15μF, 4.8mm)	117-7120
b	plastic cover	103N2011
d	cord relief	103N1010
	bracket for run capacitor	117-0300
	screw M4x8mm	117-0301

Model

Designation **NLE10CN** **115V/60Hz** Conf. 3 Sales code: **105H6194**

Optimization + standard conditions

R290, 115V/60Hz, RSCR, fan 3m/s, UL, CCC

	Evaporating pressure (saturation temperature)				Cooling capacity			COP	EER	P1	Power consumption		ASHRAE LBP	
	pe	pc	RGT	Tliq	[W]	[Btu/h]	[kcal/h]				I	m		
	[°C]	[°F]	[°C]	[°F]	[W]	[Btu/h]	[kcal/h]	[W/W]	[Btu/Wh]	[kcal/Wh]	[W]	[A]	[kg/h]	
	-23	54	32	32	616,9	2107	530,9	1,67	5,72	1,44	368,5	4,78	6,25	ASHRAE LBP
	-10	130	90	90										
	-25	55	32	55	463,8	1584	399,2	1,29	4,40	1,11	359,9	4,74	5,78	cecomaf LBP
	-13	131	90	131										
	-35	40	20	40	367,4	1255	316,2	1,39	4,75	1,20	264,3	4,18	4,20	EN12900 LBP
	-31	104	68	104										
	-7	54	35	46	1086,8	3712	935,3	2,25	7,69	1,94	482,8	5,50	12,40	ASHRAE MBP
	20	130	95	115										
	-10	55	32	55	868,0	2964	747,0	1,87	6,38	1,61	464,3	5,39	10,98	cecomaf MBP
	14	131	90	131										
	-10	45	20	45	949,4	3242	817,0	2,24	7,65	1,93	423,7	5,06	11,66	EN12900 MBP
	14	113	68	113										

Performance tables

R290, 115V/60Hz, RSCR, fan 3m/s, UL, CCC

	pe		Cooling capacity			COP	EER	P1	I	m	
	[°C]	[°F]	[W]	[Btu/h]	[kcal/h]						
[°C / °F]	-35	-31	344,8	1177	296,7	1,29	4,42	1,11	266,3	4,17	3,86
cond. pressure	-23	-10	585,3	1999	503,7	1,70	5,82	1,47	343,4	4,62	6,61
pc= 45/113	-15	5	820,5	2802	706,1	2,08	7,12	1,79	393,6	4,90	9,34
return gas temp.	-9	15	1008,2	3443	867,7	2,36	8,06	2,03	427,1	5,08	11,54
RGT= 32/90	-4	25	1221,6	4172	1051,4	2,64	9,03	2,28	462,1	5,27	14,09
liquid temp	0	32	1386,7	4736	1193,4	2,84	9,70	2,44	488,1	5,42	16,08
Tliq= 45/113	7,2	45	1728,7	5904	1487,8	3,19	10,90	2,75	541,4	5,72	20,31
[°C / °F]	-35	-31	286,2	978	246,3	1,02	3,48	0,88	281,1	4,27	3,54
cond. pressure	-23	-10	500,3	1709	430,6	1,34	4,59	1,16	372,0	4,81	6,24
pc= 55/131	-15	5	714,1	2439	614,6	1,66	5,67	1,43	430,2	5,17	8,98
return gas temp	-9	15	886,3	3027	762,8	1,89	6,47	1,63	468,1	5,42	11,22
RGT= 32/90	-4	25	1083,3	3700	932,3	2,14	7,30	1,84	506,9	5,67	13,82
liquid temp	0	32	1236,3	4222	1064,0	2,31	7,89	1,99	535,1	5,87	15,88
Tliq= 55/131	7,2	45	1554,6	5309	1337,9	2,63	8,97	2,26	591,6	6,28	20,25



8238-20

NL Compressors

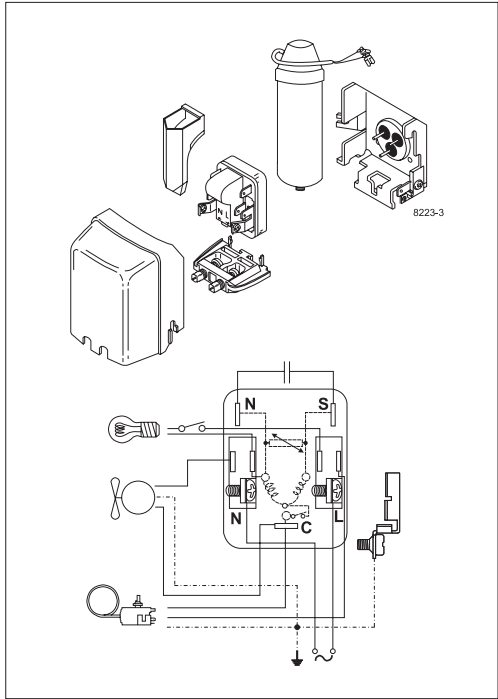
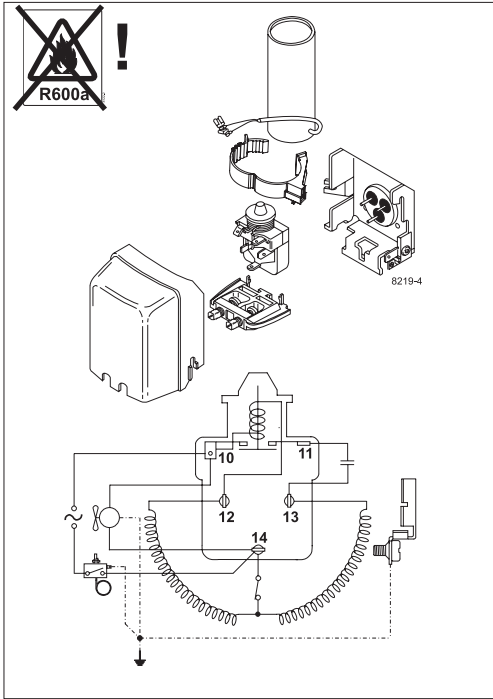
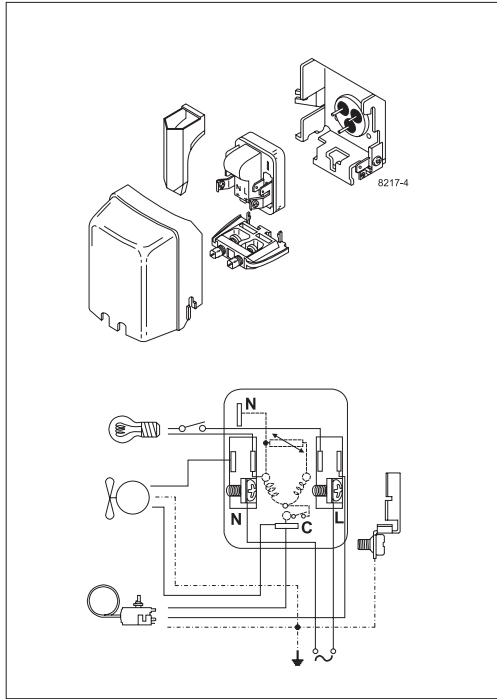



Service/Repair – R600a, R290



8545

Brazing on Suction Connectors (Direct Intake)

representative image



**! max. 150°C/302°F !
at socket**
brazing solder: phosphor (LP7) or silver

Refer to Product Bulletin:
**Brazing on Suction Connectors
(Compressors with Direct Suction Intake)**

Secop accepts no responsibility for possible errors in catalogs, brochures, and other printed material. Secop reserves the right to alter its products without notice. This also applies to products already on order provided that such alterations can be made without subsequential changes being necessary to specifications already agreed. All trademarks in this material are the property of the respective companies. Secop and the Secop logotype are trademarks of Secop GmbH. All rights reserved. www.secop.com