

Single Pack BD350GH 12V DC PM

Codice Imballo Singolo: **195B4552**

Posizione	Titolo	Codice	Quantità
1	Compressor BD350GH	102Z3015	1
2	Compressor module	101N0801	1
3	Application module	101N0821	1
4	Communication cable (3000mm)	105N9554	1
5	Temperature sensor	105N9612	1
6	Bolt joint for one compressor M6 ø16mm	118-1917	1

Secop GmbH · Lise-Meitner-Straße 29 · 24941 Flensburg, Germany · Tel: +49 46149410 · www.secop.com

Secop non si assume alcuna responsabilità per eventuali errori presenti in cataloghi, brochure e altro materiale stampato. Secop si riserva il diritto di modificare i propri prodotti senza preavviso. Ciò vale anche per i prodotti già ordinati, a condizione che tali modifiche possano essere apportate senza che siano necessarie modifiche successive alle specifiche già concordate. Tutti i marchi presenti in questo materiale sono di proprietà delle rispettive aziende. Secop e il logo Secop sono marchi di Secop GmbH. Tutti i diritti sono riservati.

BD350GH Direct Current Compressor R134a 12V DC - with 101N08xx Series Controllers

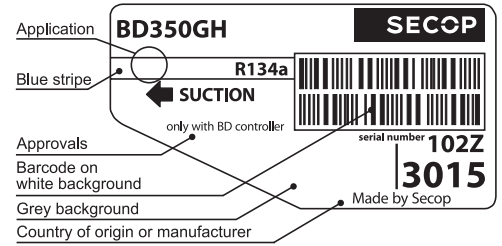

General

Code number (without electronic units)	102Z3015
Compressor module	101N0800, 30 pcs: 101N0801
Application module	101N0820, 30 pcs: 101N0821
Alternative (one interface only): Electronic Unit (no fan connection/no twin option)	101N0830, 30 pcs: 101N0831
Approvals	-
Compressors on pallet	125

Application

Application	LBP/MBP/HBP
Evaporating temperature °C	-25 to 15
Voltage range VDC	9.6 - 17
Max. condensing temperature continuous (short) °C	60 (70)
Max. winding temperature continuous (short) °C	125 (135)

- S = Static cooling normally sufficient
- O = Oil cooling
- F₁ = Fan cooling 1.5 m/s
(compressor compartment temperature equal to ambient temperature)
- F₂ = Fan cooling 3.0 m/s necessary
- SG = Suction gas cooling normally sufficient
- = not applicable in this area

Cooling requirements

Application	LBP	MBP	HBP
32°C	F ₁	F ₁	F ₁
38°C	F ₁	F ₁	F ₁
43°C	F ₁	F ₁	F ₁
Remarks on application: - evaporator fan max. 200W - condenser fan max. 100W - starting ability: LST (low starting torque) only			

Motor

Motor type	Variable speed
Resistance, all 3 windings (25°C) Ω	0.1

Design

Displacement cm ³	5.08
Oil quantity (type) cm ³	280 (polyolester)
Maximum refrigerant charge g	400
Free gas volume in compressor cm ³	1690
Weight - Compressor/Electronic unit kg	7.9 / 0.33 / 0.28 (101N820)

Battery protection settings

Voltage	Min. value	Default	Max. value
Cut out (0.1 steps) VDC	9.6	10.4	17
Cut in diff. (0.1 steps) VDC	0.5	1.3	10

Dimensions

Height mm	A	173
	B	169
	B1	-
	B2	-
Suction connector location/I.D. mm angle	C	6.2 90°
	material comment	Cu-plated steel Al cap
Process connector location/I.D. mm angle	D	6.2 31.5°
	material comment	Cu-plated steel Al cap
Discharge connector location/I.D. mm angle	E	5.0 28°
	material comment	Cu-plated steel Al cap
Connector tolerance I.D. mm		±0.09, on 5.0 +0.12/+0.20

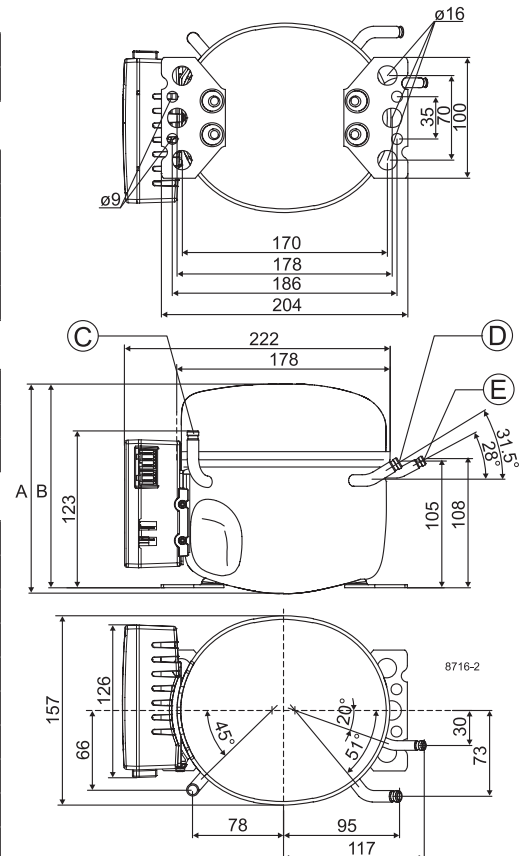

Capacity (EN 12900 Household/CECOMAF)												
12V DC, fan cooling F ₁ watt												
rpm \ °C	-25	-23.3	-20	-15	-10	-6.7	-5	0	5	7.2	10	15
2,500	87.5	96.9	117	152	194	226	244	302	370	403	448	538
3,000	101	112	136	177	225	262	283	351	430	468	521	625
3,500	114	126	152	198	254	296	319	396	485	528	588	706
4,000	126	139	169	220	282	329	355	440	540	588	654	786

Capacity (ASHRAE LBP)												
12V DC, fan cooling F ₁ watt												
rpm \ °C	-25	-23.3	-20	-15	-10	-6.7	-5	0	5	7.2	10	15
2,500	108	120	145	188.3	240	280	302	375	459	501	557	670
3,000	126	139	168	219	279	325	351	435	534	582	648	778
3,500	141	156	188	246	314	366	395	491	602	656	731	879
4,000	156	173	209	273	349	407	440	546	670	731	814	979

Power consumption												
12V DC, fan cooling F ₁ watt												
rpm \ °C	-25	-23.3	-20	-15	-10	-6.7	-5	0	5	7.2	10	15
2,500	90.5	95.6	106	123	140	152	156	177	196	204	215	233
3,000	108	114	127	148	169	184	192	215	238	248	261	284
3,500	122	130	146	170	197	214	224	252	280	292	308	335
4,000	140	149	168	197	228	249	259	292	325	340	358	391

Current consumption												
12V DC, fan cooling F ₁ A												
rpm \ °C	-25	-23.3	-20	-15	-10	-6.7	-5	0	5	7.2	10	15
2,500	7.71	8.15	9.03	10.45	11.93	12.95	13.48	15.06	16.65	17.36	18.25	19.82
3,000	8.99	9.52	10.60	12.32	14.12	15.35	16.00	17.92	19.86	20.71	21.79	23.70
3,500	10.46	11.10	12.39	14.47	16.65	18.13	18.91	21.23	23.57	24.60	25.90	28.21
4,000	11.70	12.46	13.98	16.41	18.97	20.72	21.63	24.35	27.10	28.31	29.84	32.55

COP (EN 12900 Household/CECOMAF)												
12V DC, fan cooling F ₁ W/W												
rpm \ °C	-25	-23.3	-20	-15	-10	-6.7	-5	0	5	7.2	10	15
2,500	0.97	1.01	1.10	1.24	1.38	1.48	1.54	1.71	1.89	1.97	2.09	2.30
3,000	0.94	0.98	1.07	1.20	1.33	1.43	1.48	1.63	1.81	1.89	1.99	2.20
3,500	0.93	0.97	1.04	1.16	1.29	1.38	1.43	1.57	1.73	1.81	1.91	2.10
4,000	0.90	0.93	1.01	1.12	1.24	1.32	1.37	1.51	1.66	1.73	1.83	2.01

COP (ASHRAE LBP)												
12V DC, fan cooling F ₁ W/W												
rpm \ °C	-25	-23.3	-20	-15	-10	-6.7	-5	0	5	7.2	10	15
2,500	1.20	1.26	1.37	1.54	1.72	1.85	1.92	2.13	2.36	2.47	2.61	2.89
3,000	1.17	1.22	1.33	1.49	1.66	1.78	1.84	2.04	2.26	2.36	2.50	2.76
3,500	1.15	1.20	1.30	1.45	1.61	1.72	1.78	1.96	2.17	2.26	2.39	2.64
4,000	1.11	1.16	1.25	1.39	1.54	1.65	1.70	1.88	2.08	2.17	2.29	2.53

Test conditions	EN 12900/CECOMAF	ASHRAE LBP
Condensing temperature	55°C	54.4°C
Ambient temperature	32°C	32°C
Suction gas temperature	32°C	32°C
Liquid temperature	no subcooling	32°C

Operational errors	
Error code	Error type
	Can be read out in the software TOOL4COOL®
6	Thermostat failure (If the NTC thermistor is short-circuit or has no connection, the electronic unit will enter manual mode).
5	Thermal cut-out of electronic unit (If the refrigeration system has been too heavily loaded, or if the ambient temperature is high, the electronic unit will run too hot).
4	Minimum motor speed error (If the refrigeration system is too heavily loaded, the motor cannot maintain minimum speed at approximately 1,850 rpm).
3	Motor start error (The rotor is blocked or the differential pressure in the refrigeration system is too high).
2	Fan over-current cut-out (The fan loads the electronic unit with too high current).
1	Battery protection cut-out (The voltage is outside the cut-out setting).

Accessories for BD350GH	
Mounting	Code number
Bolt joint for one compressor	Ø: 16 mm 118-1917
Bolt joint in quantities	Ø: 16 mm 118-1918
Snap-on in quantities	Ø: 16 mm 118-1919

Electrical (cables, sensors, etc.)	Code number	
	Single pack	I - Pack
One Wire/LIN gateway communication cable	105N9501	-
Bluetooth® gateway communication cable	105N9502	-
Temperature sensor 470 mm	105N9612	105N9613, 200 pcs.
Temperature sensor 1000 mm	105N9614	105N9615, 100 pcs.
Temperature sensor 1500 mm	105N9616	105N9617, 100 pcs.
Comm. cable, 1500 mm	-	105N9553, 80 pcs.
Comm. cable, 3000 mm	-	105N9554, 45 pcs.
Display cable, 1500 mm	-	105N9557, 65 pcs.
Display cable, 3000 mm	-	105N9558, 35 pcs.

Not deliverable from Secop	
Slow-blow fuse compressor module	60A
Slow-blow fuse application module	30A
Main switch	rated to min. 100A

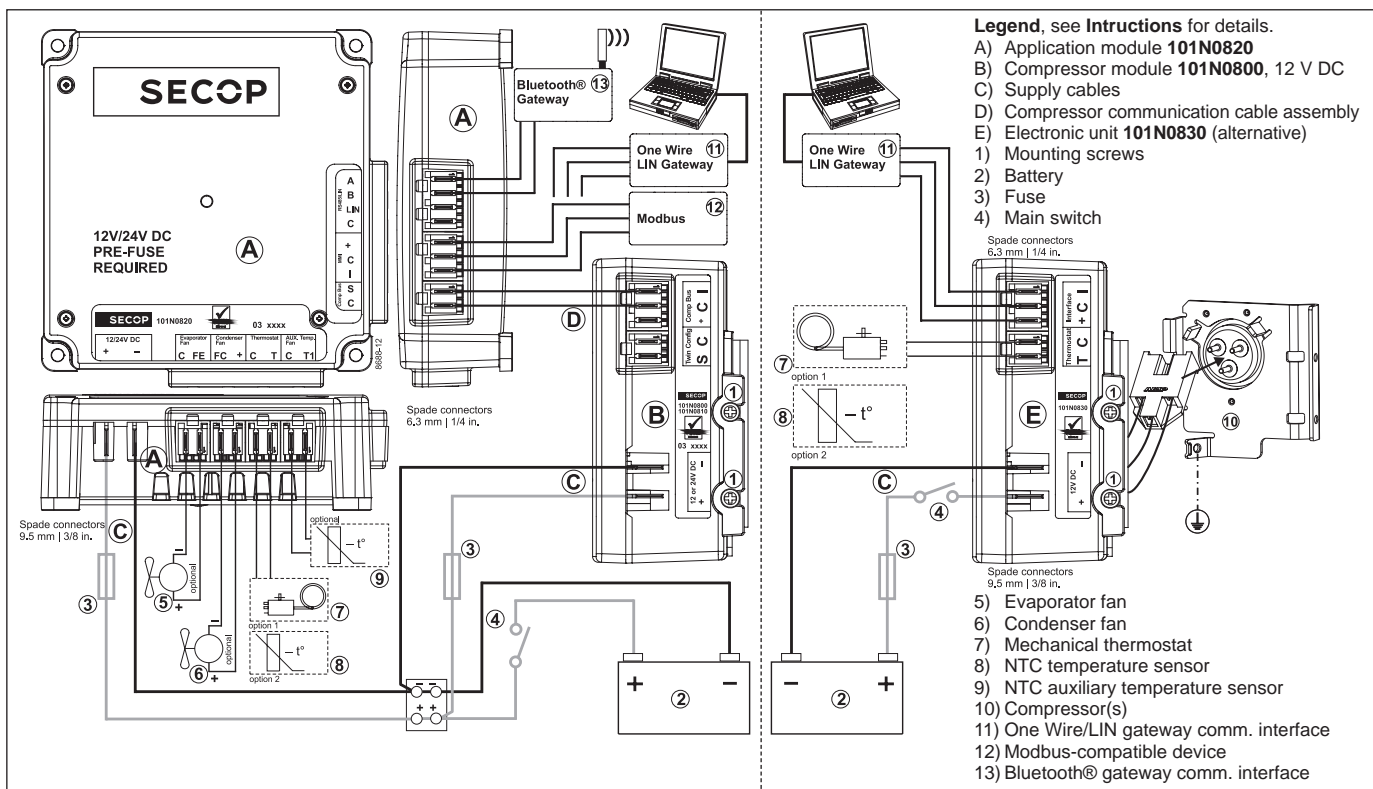

Secop accepts no responsibility for possible errors in catalogs, brochures, and other printed material. Secop reserves the right to alter its products without notice. This also applies to products already on order provided that such alterations can be made without consequential changes being necessary to specifications already agreed. All trademarks in this material are the property of the respective companies. Secop and the Secop logotype are trademarks of Secop GmbH. All rights reserved. www.secop.com



Instructions for Electronic Units
are available for download on
www.secop.com



BD Compressors



Service/Repair

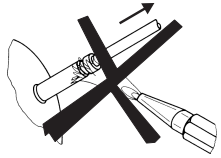

BD Nano



**! max. 150°C/302°F !
at socket**
brazing solder: silver with flux

Do not heat up the bottom of the discharge connector directly.
Do not braze longer than 10 seconds and wait for 5 minutes for the next soldering attempt (Product Bulletin DES.N.101.M1).

BD Micro

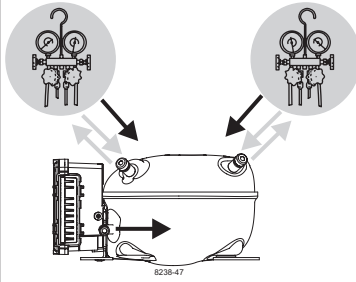

BD P-Housing

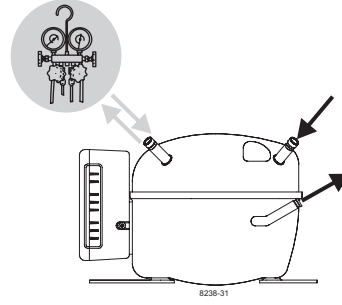

BD T-Housing



Secop accepts no responsibility for possible errors in catalogs, brochures, and other printed material. Secop reserves the right to alter its products without notice. This also applies to products already on order provided that such alterations can be made without subsequential changes being necessary to specifications already agreed. All trademarks in this material are the property of the respective companies. Secop and the Secop logotype are trademarks of Secop GmbH. All rights reserved. www.secop.com