

## Single Pack TLES5.7KK.3 220-240V 50Hz RSIR

Codice Imballo Singolo: **195B4561**

Posizione	Titolo	Codice	Quantità
1	Compressor TLES5.7KK.3	102H4694	1
2	PTC starting device (220V, 250hm, 6.3mm)	103N0011	1
3	Cord relief	103N1010	1
4	Protection screen for PTC	103N0476	1
5	Cover	103N2010	1
6	Bolt joint for one compressor   M6   ø16mm	118-1917	1

**Secop GmbH** • Lise-Meitner-Straße 29 • 24941 Flensburg, Germany • Tel: +49 46149410 • [www.secop.com](http://www.secop.com)

Secop non si assume alcuna responsabilità per eventuali errori presenti in cataloghi, brochure e altro materiale stampato. Secop si riserva il diritto di modificare i propri prodotti senza preavviso. Ciò vale anche per i prodotti già ordinati, a condizione che tali modifiche possano essere apportate senza che siano necessarie modifiche successive alle specifiche già concordate. Tutti i marchi presenti in questo materiale sono di proprietà delle rispettive aziende. Secop e il logo Secop sono marchi di Secop GmbH. Tutti i diritti sono riservati.

## Model

Designation	<b>TLES5.7KK.3</b>	220-240V/50Hz 1~	Sales code:	<b>102H4694</b>
-------------	--------------------	------------------	-------------	-----------------

## Compressor design

Oil type	Mineral	Refrigerant(s)	<b>R600a</b>
Oil viscosity	9,6cST	Displacement	5,7cm <sup>3</sup> / 0,35cu.in
Oil quantity	180cm <sup>3</sup> / 6,1fl.oz	Compressors on pallet	125
Refr. charge - tech. limit	150g / 5,3oz		
Free gas volume comp.	1690cm <sup>3</sup> / 57,1fl.oz		
Weight	6,4kg / 14,1lbs		
Motor protection	1# internal		
Winding resistance main	0Ω (at 25°C)		
Winding resistance aux	0Ω (at 25°C)		
Max. winding temp.	125°C / 257°F		
Max. discharge temp.	130°C / 266°F		



## General - Configurations with TLES5.7KK.3

	<b>Conf. 1</b>	<b>Conf. 2</b>	<b>Conf. 3</b>	<b>Conf. 4</b>
Motorconfiguration	RSIR	RSCR	RSCR	RSCR
Power supply (nominal)	220-240V/50Hz	220-240V/50Hz	220-240V/50Hz	220-240V/50Hz
Number of phases	1	1	1	1
Voltage range	198-254V	198-254V	198-254V	198-254V
Approvals	VDE, EAC	VDE, EAC	VDE, EAC	VDE, EAC
Starting torque	LST	LST	LST	LST
Note	- / -			

## Applications with TLES5.7KK.3

	<b>Conf. 1</b>	<b>Conf. 2</b>	<b>Conf. 3</b>	<b>Conf. 4</b>
Refrigerant	R600a	R600a	R600a	R600a
Application	LBP	LBP	LBP	LBP
System cooling	static	static	static	static
Hot gas defrost	- / -	- / -	- / -	- / -
Long interval pull down	- / -	- / -	- / -	- / -

## Electrical data - Configurations with TLES5.7KK.3

	<b>Conf. 1</b>	<b>Conf. 2</b>	<b>Conf. 3</b>	<b>Conf. 4</b>
Starting device type	PTC	PTC	PTC	PTC
Run capacitor	- / -	4μF	4μF	4μF
Start capacitor	- / -	- / -	- / -	- / -
LRA (locked rotor amps / 4s)	2,2A			
RLA (rated load amps / 1s)	0,5A	0,5A	0,5A	0,5A
Cut in current	6,7A			

## Model

Designation

**TLES5.7KK.3**

220-240V/50Hz 1~

Sales code:

**102H4694**

## Compressor dimensions

Housing	A Height	163mm / 6,42in
	B Height	159mm / 6,26in
	C Length shell	176mm / 6,93in
	D Length w. cover	222mm / 8,74in
	E Width	157mm / 6,18in

Connectors		Suction	Discharge	Process
		X	Y	Z
Diameter	[mm]	øi 6,11-6,29	øi 5,12-5,22	øi 6,11-6,29
(i:inside, o:outside)	[in]	øi 0,24-0,25	øi 0,2-0,21	øi 0,24-0,25
Material		copper	copper	copper
Horizontal angle	±2°	0°	0°	0°
Vertical angle	±2°	150°	28°	31,5°
Position l/h/w	[mm]	-102/105/66	117/108/30	96/105/71
	[in]	-4/4,1/2,6	4,6/4,3/1,2	3,8/4,1/2,8
Straight tube l.	[mm]	12	12	12
	[in]	0,5	0,5	0,5

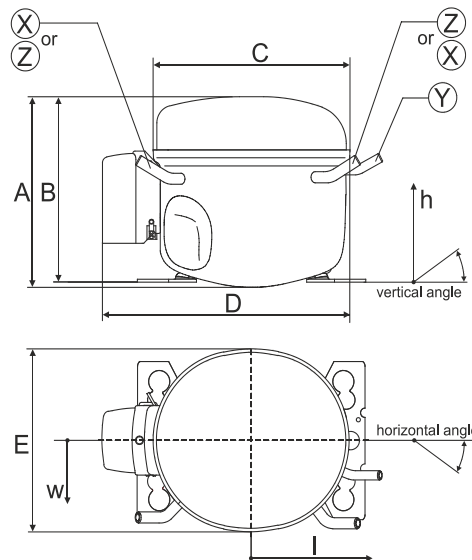

## Compressor fixation

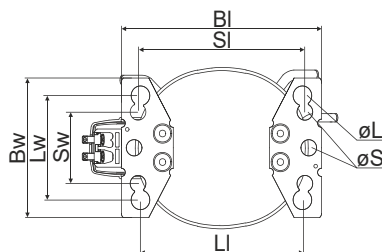

Baseplate	[mm]	[inch]
BI	204	8.03
BW	136	5.35
Large holes	[mm]	[inch]
LI	165	6.5
Lw	101.6	4
øL	ø 19	ø 0.75
Small holes	[mm]	[inch]
SI	170	6.7
Sw	70	2.76
øS	ø 16	ø 0.63

### Bolt joint

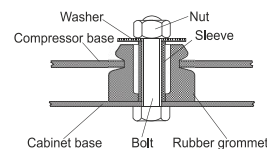

### Snap-on

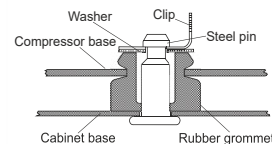

## Mounting accessories

	one comp.	multi pack
Bolt joint   M6   ø16mm	118-1917	118-1918
Bolt joint   ø1/4"   ø16mm	118-1946	
Snap-on   ø7,3   ø16mm	118-1947	118-1919

## Model

Designation	<b>TLES5.7KK.3</b>	<b>220-240V/50Hz</b>	Conf. 1	Sales code:	<b>102H4694</b>
-------------	--------------------	----------------------	---------	-------------	-----------------

## Configuration

Motorconfiguration	RSIR
Power supply (nominal)	220-240V/50Hz 1~
Refrigerant	R600a
Application	LBP
Voltage range	198-254V
Starting torque	LST
Approvals	VDE
	EAC

## Electrical accessories / wiring diagram

RSIR

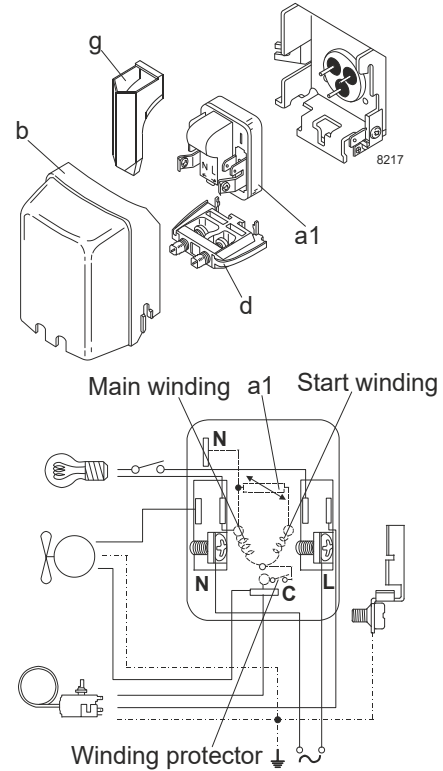

## Ambient temperatures / system cooling

Ambient temperature min.:	10°C / 50°F
Ambient temperature max.:	43°C / 110°F

System cooling (n/a: outside limits)			
T ambient	LBP	MBP	HBP
32°C / 90°F	static	n/a	n/a
38°C / 100°F	static	n/a	n/a
43°C / 110°F	static	n/a	n/a

## Operation pressure range

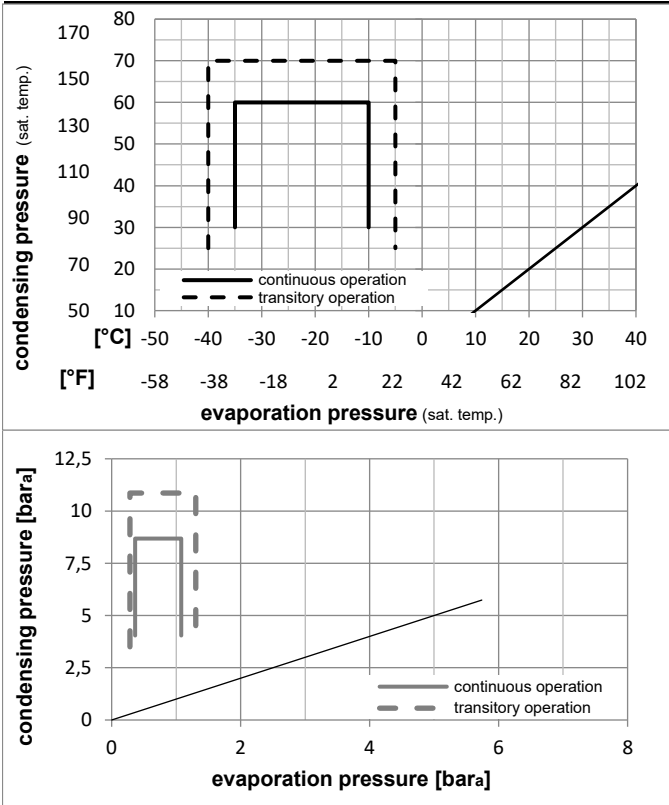

## Components

a1	PTC starter (220V, 250hm, 4.8mm)	103N0018
b	plastic cover	103N2010
d	cord relief	103N1010
g	protection screen for PTC	103N0476

## Alternative components

a1	PTC starter (220V, 250hm, 6.3mm)	103N0011
b	plastic cover	103N2011
d	cord relief	103N1010
g	protection screen for PTC	103N0476

### Model

Designation **TLES5.7KK.3 220-240V/50Hz** Conf. 1 Sales code: **102H4694**

### Optimization + standard conditions

R600a, 220V/50Hz, RSIR, static, VDE, EAC

	Evaporating pressure (saturation temperature)				Condensing pressure (saturation temperature)			Return gas temp.			Liquid temp.			Cooling capacity			COP	EER	Power consumption			
	pe	pc	RGT	Tliq	[W]	[Btu/h]	[kcal/h]	[W/W]	[Btu/Wh]	[kcal/Wh]	P1	I	m	[W]	[A]	[kg/h]						
[°C]	-23	54	32	32	91,0	311	78,4	1,32	4,50	1,13	69,1	0,50	0,98								ASHRAE LBP	
[°F]	-10	130	90	90																		
[°C]	-25	55	32	55	68,0	232	58,6	1,02	3,49	0,88	66,5	0,49	0,89								cecomaf LBP	
[°F]	-13	131	90	131																		
[°C]	-35	40	20	40	47,7	163	41,1	0,92	3,16	0,80	51,6	0,44	0,58								EN12900 LBP	
[°F]	-31	104	68	104																		
[°C]	-23	49	4,4	49	74,7	255	64,3	1,11	3,79	0,95	67,4	0,49	1,09								ARI540 LBP	
[°F]	-10	120	40	120																		
[°C]	-23	41	32	32	99,5	340	85,7	1,55	5,28	1,33	64,4	0,49	1,07								AHAM LBP	
[°F]	-10	105	90	90																		
[°C]	-35	45	32	45	45,0	154	38,7	0,87	2,98	0,75	51,6	0,44	0,53								opt	
[°F]	-31	113	90	113																		

### Performance tables

R600a, 220V/50Hz, RSIR, static, VDE, EAC

	pe	Cooling capacity			COP	EER	P1			I	m
	[°C]	[°F]	[W]	[Btu/h]	[kcal/h]	[W/W]	[Btu/Wh]	[kcal/Wh]	[W]	[A]	[kg/h]
[°C / °F]	-35	-31	45,0	154	38,7	0,87	2,98	0,75	51,6	0,44	0,53
cond. pressure	-30	-22	60,9	208	52,4	1,05	3,60	0,91	57,7	0,46	0,72
pc= 45/113	-25	-13	80,2	274	69,0	1,25	4,28	1,08	63,9	0,48	0,95
return gas temp.	-23	-10	87,6	299	75,4	1,33	4,53	1,14	66,1	0,49	1,04
RGT= 32/90	-20	-4	103,4	353	89,0	1,47	5,01	1,26	70,5	0,51	1,23
liquid temp	-15	5	131,0	447	112,7	1,68	5,75	1,45	77,8	0,53	1,56
Tliq= 45/113	-10	14	163,4	558	140,6	1,90	6,48	1,63	86,2	0,56	1,96
[°C / °F]	-35	-31	36,4	124	31,3	0,73	2,48	0,63	50,1	0,43	0,47
cond. pressure	-30	-22	50,7	173	43,6	0,87	2,96	0,75	58,4	0,46	0,66
pc= 55/131	-25	-13	68,0	232	58,6	1,02	3,49	0,88	66,5	0,49	0,89
return gas temp	-23	-10	74,7	255	64,3	1,08	3,68	0,93	69,3	0,50	0,98
RGT= 32/90	-20	-4	89,0	304	76,6	1,19	4,06	1,02	74,8	0,52	1,16
liquid temp	-15	5	114,1	390	98,2	1,36	4,65	1,17	83,7	0,55	1,49
Tliq= 55/131	-10	14	143,7	491	123,7	1,54	5,25	1,32	93,4	0,59	1,89

## Model

Designation	<b>TLES5.7KK.3</b>	<b>220-240V/50Hz</b>	<b>Conf. 2</b>	Sales code:	<b>102H4694</b>
-------------	--------------------	----------------------	----------------	-------------	-----------------

## Configuration

Motorconfiguration	RSCR
Power supply (nominal)	220-240V/50Hz 1~
Refrigerant	R600a
Application	LBP
Voltage range	198-254V
Starting torque	LST
Approvals	VDE
	EAC

## Electrical accessories / wiring diagram

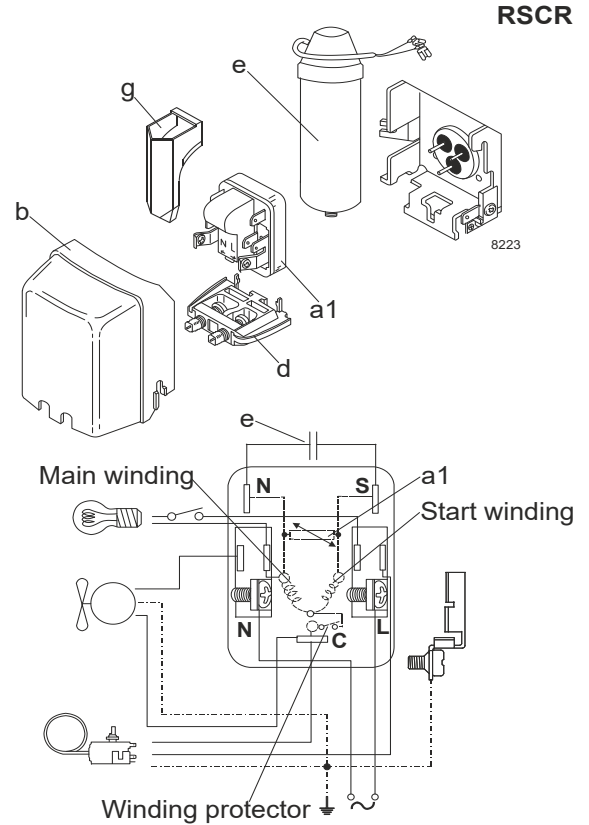

## Ambient temperatures / system cooling

Ambient temperature min.:	10°C / 50°F
Ambient temperature max.:	43°C / 110°F

System cooling (n/a: outside limits)			
T ambient	LBP	MBP	HBP
32°C / 90°F	static	n/a	n/a
38°C / 100°F	static	n/a	n/a
43°C / 110°F	static	n/a	n/a

## Operation pressure range

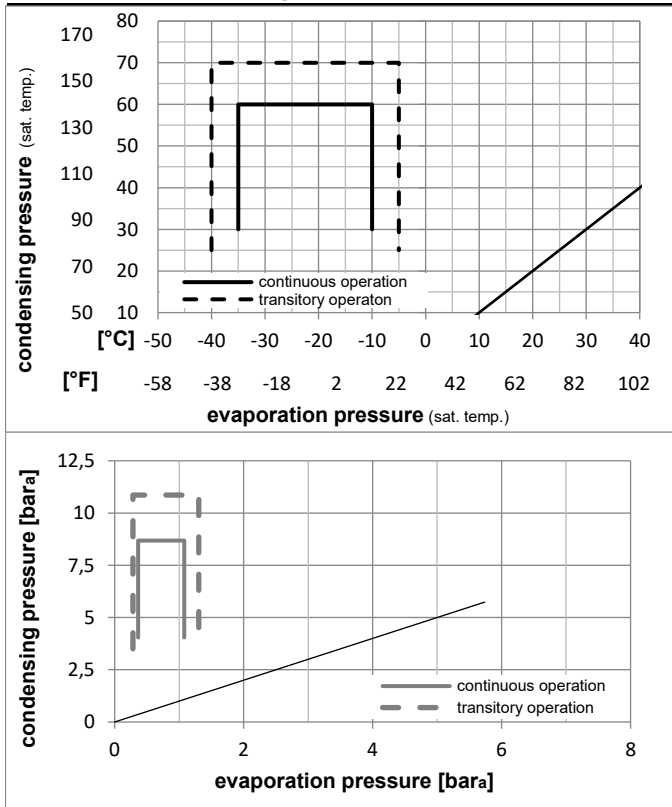

## Components

a1	PTC starter (220V, 250hm, 6.3mm)	103N0016
e	run capacitor (4μF, 6.3mm)	117-7117
b	plastic cover	103N2010
d	cord relief	103N1010
g	protection screen for PTC	103N0476
	bracket for run capacitor	117-0300

## Alternative components

b	plastic cover	103N2011
---	---------------	----------

### Model

Designation **TLES5.7KK.3 220-240V/50Hz** Conf. 2 Sales code: **102H4694**

### Optimization + standard conditions

R600a, 220V/50Hz, RSCR, static, VDE, EAC

	pe	pc	RGT	Tliq	Cooling capacity	COP	EER	P1	I	Ref. mass flow	
	[°C]	[°C]	[°C]	[°C]	[W]	[W/W]	[Btu/Wh]	[W]	[A]	[kg/h]	
	[°F]	[°F]	[°F]	[°F]	[Btu/h]	[kcal/h]	[Btu/Wh]	[W]	[A]	[kg/h]	
ASHRAE LBP	-23	54	32	32	92,0	1,37	4,68	67,2	0,49	0,99	
	-10	130	90	90							
cecomaf LBP	-25	55	32	55	68,8	1,06	3,63	64,7	0,48	0,90	
	-13	131	90	131							
EN12900 LBP	-35	40	20	40	48,2	0,96	3,28	50,2	0,43	0,59	
	-31	104	68	104							
ARI540 LBP	-23	49	4,4	49	75,5	1,15	3,94	65,5	0,48	1,10	
	-10	120	40	120							
AHAM LBP	-23	41	32	32	100,6	1,61	5,49	62,6	0,47	1,08	
	-10	105	90	90							
opt	-35	45	32	45	45,5	0,91	3,09	50,2	0,42	0,54	
	-31	113	90	113							

### Performance tables

R600a, 220V/50Hz, RSCR, static, VDE, EAC

	pe	Cooling capacity			COP	EER	P1	I	m		
	[°C]	[°F]	[W]	[Btu/h]	[kcal/h]	[W/W]	[Btu/Wh]	[kcal/Wh]	[W]	[A]	[kg/h]
[°C / °F]	-35	-31	45,5	155	39,1	0,91	3,09	0,78	50,2	0,42	0,54
cond. pressure	-30	-22	61,5	210	52,9	1,10	3,74	0,94	56,1	0,45	0,73
pc= 45/113	-25	-13	81,0	277	69,7	1,30	4,46	1,12	62,1	0,47	0,96
return gas temp.	-23	-10	88,5	302	76,2	1,38	4,71	1,19	64,2	0,48	1,05
RGT= 32/90	-20	-4	104,5	357	89,9	1,53	5,21	1,31	68,5	0,49	1,25
liquid temp	-15	5	132,4	452	113,9	1,75	5,98	1,51	75,6	0,52	1,58
Tliq= 45/113	-10	14	165,2	564	142,2	1,97	6,73	1,70	83,8	0,55	1,98
[°C / °F]	-35	-31	36,8	126	31,7	0,76	2,58	0,65	48,7	0,42	0,48
cond. pressure	-30	-22	51,2	175	44,1	0,90	3,08	0,78	56,8	0,45	0,67
pc= 55/131	-25	-13	68,8	235	59,2	1,06	3,63	0,92	64,7	0,48	0,90
return gas temp	-23	-10	75,6	258	65,0	1,12	3,83	0,97	67,4	0,49	0,99
RGT= 32/90	-20	-4	90,0	307	77,4	1,24	4,22	1,06	72,8	0,51	1,18
liquid temp	-15	5	115,3	394	99,2	1,42	4,84	1,22	81,4	0,54	1,51
Tliq= 55/131	-10	14	145,3	496	125,0	1,60	5,46	1,38	90,8	0,57	1,91

## Model

Designation **TLES5.7KK.3** **220-240V/50Hz** Conf. 3 Sales code: **102H4694**

## Configuration

Motorconfiguration RSCR  
 Power supply (nominal) 220-240V/50Hz 1~  
 Refrigerant R600a  
 Application LBP  
 Voltage range 198-254V  
 Starting torque LST  
 Approvals VDE  
 EAC

## Electrical accessories / wiring diagram

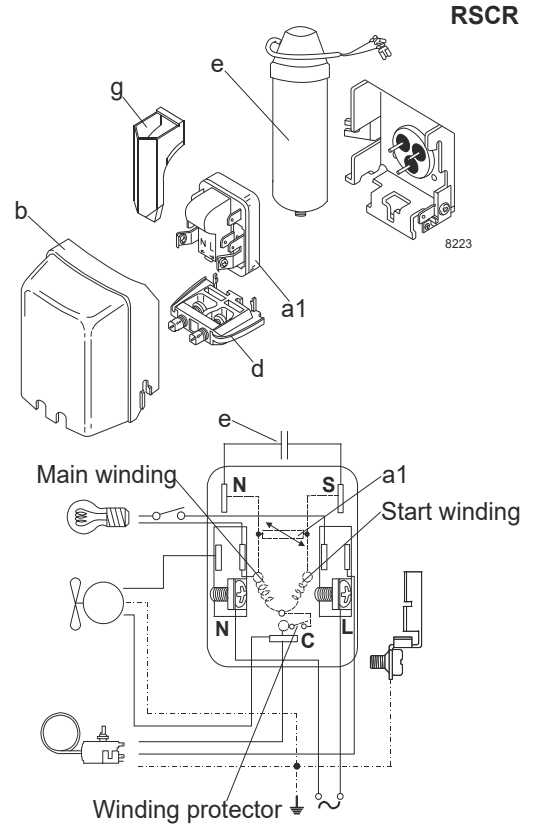

## Ambient temperatures / system cooling

Ambient temperature min.: 10°C / 50°F  
 Ambient temperature max.: 43°C / 110°F

System cooling (n/a: outside limits)			
T ambient	LBP	MBP	HBP
32°C / 90°F	static	n/a	n/a
38°C / 100°F	static	n/a	n/a
43°C / 110°F	static	n/a	n/a

## Operation pressure range

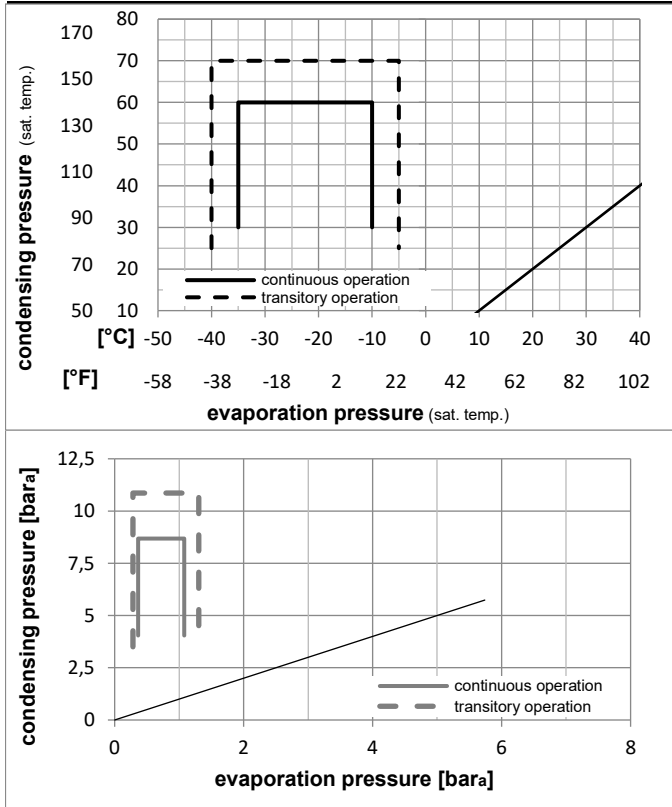

## Components

- a1 PTC starter (220V, 250hm, 4.8mm) 103N0021
- e run capacitor (4μF, 4.8mm) 117-7119
- b plastic cover 103N2010
- d cord relief 103N1010
- g protection screen for PTC 103N0476
- bracket for run capacitor 117-0300

## Alternative components

- b plastic cover 103N2011



### Model

Designation **TLES5.7KK.3 220-240V/50Hz** Conf. 3 Sales code: **102H4694**

### Optimization + standard conditions

R600a, 220V/50Hz, RSCR, static, VDE, EAC

	pe	pc	RGT	Tliq	Cooling capacity	COP	EER	P1	I	Ref. mass flow	
	[°C]	[°C]	[°C]	[°C]	[W]	[W/W]	[Btu/Wh]	[W]	[A]	[kg/h]	
	[°F]	[°F]	[°F]	[°F]	[Btu/h]	[kcal/h]	[Btu/Wh]	[W]	[A]	[kg/h]	
ASHRAE LBP	-23	54	32	32	92,0	1,37	4,68	67,2	0,49	0,99	
	-10	130	90	90							
cecomaf LBP	-25	55	32	55	68,8	1,06	3,63	64,7	0,48	0,90	
	-13	131	90	131							
EN12900 LBP	-35	40	20	40	48,2	0,96	3,28	50,2	0,43	0,59	
	-31	104	68	104							
ARI540 LBP	-23	49	4,4	49	75,5	1,15	3,94	65,5	0,48	1,10	
	-10	120	40	120							
AHAM LBP	-23	41	32	32	100,6	1,61	5,49	62,6	0,47	1,08	
	-10	105	90	90							
opt	-35	45	32	45	45,5	0,91	3,09	50,2	0,42	0,54	
	-31	113	90	113							

### Performance tables

R600a, 220V/50Hz, RSCR, static, VDE, EAC

	pe	Cooling capacity			COP	EER	P1	I	m		
	[°C]	[°F]	[W]	[Btu/h]	[kcal/h]	[W/W]	[Btu/Wh]	[kcal/Wh]	[W]	[A]	[kg/h]
[°C / °F]	-35	-31	45,5	155	39,1	0,91	3,09	0,78	50,2	0,42	0,54
cond. pressure	-30	-22	61,5	210	52,9	1,10	3,74	0,94	56,1	0,45	0,73
pc= 45/113	-25	-13	81,0	277	69,7	1,30	4,46	1,12	62,1	0,47	0,96
return gas temp.	-23	-10	88,5	302	76,2	1,38	4,71	1,19	64,2	0,48	1,05
RGT= 32/90	-20	-4	104,5	357	89,9	1,53	5,21	1,31	68,5	0,49	1,25
liquid temp	-15	5	132,4	452	113,9	1,75	5,98	1,51	75,6	0,52	1,58
Tliq= 45/113	-10	14	165,2	564	142,2	1,97	6,73	1,70	83,8	0,55	1,98
[°C / °F]	-35	-31	36,8	126	31,7	0,76	2,58	0,65	48,7	0,42	0,48
cond. pressure	-30	-22	51,2	175	44,1	0,90	3,08	0,78	56,8	0,45	0,67
pc= 55/131	-25	-13	68,8	235	59,2	1,06	3,63	0,92	64,7	0,48	0,90
return gas temp	-23	-10	75,6	258	65,0	1,12	3,83	0,97	67,4	0,49	0,99
RGT= 32/90	-20	-4	90,0	307	77,4	1,24	4,22	1,06	72,8	0,51	1,18
liquid temp	-15	5	115,3	394	99,2	1,42	4,84	1,22	81,4	0,54	1,51
Tliq= 55/131	-10	14	145,3	496	125,0	1,60	5,46	1,38	90,8	0,57	1,91

## Model

Designation	<b>TLES5.7KK.3</b>	<b>220-240V/50Hz</b>	Conf. 4	Sales code:	<b>102H4694</b>
-------------	--------------------	----------------------	---------	-------------	-----------------

## Configuration

Motorconfiguration	RSCR
Power supply (nominal)	220-240V/50Hz 1~
Refrigerant	R600a
Application	LBP
Voltage range	198-254V
Starting torque	LST
Approvals	VDE
	EAC

## Electrical accessories / wiring diagram

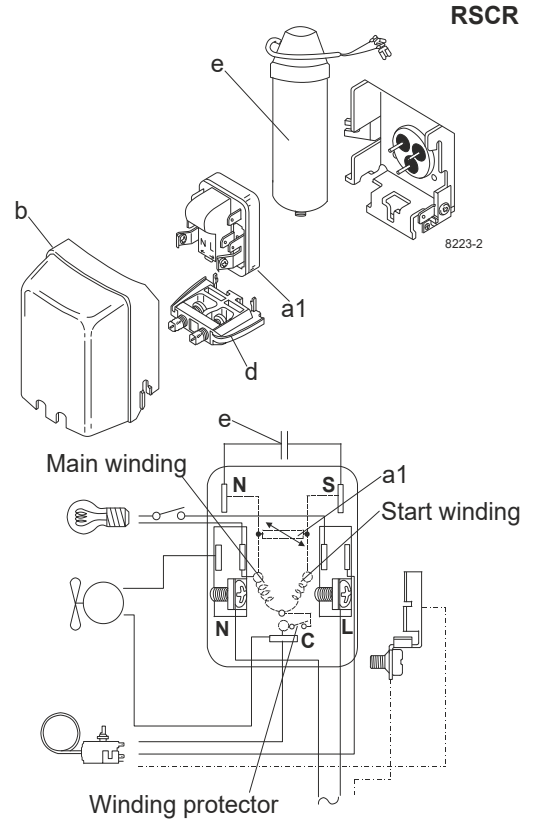

## Ambient temperatures / system cooling

Ambient temperature min.:	10°C / 50°F
Ambient temperature max.:	43°C / 110°F

System cooling (n/a: outside limits)			
T ambient	LBP	MBP	HBP
32°C / 90°F	static	n/a	n/a
38°C / 100°F	static	n/a	n/a
43°C / 110°F	static	n/a	n/a

## Operation pressure range

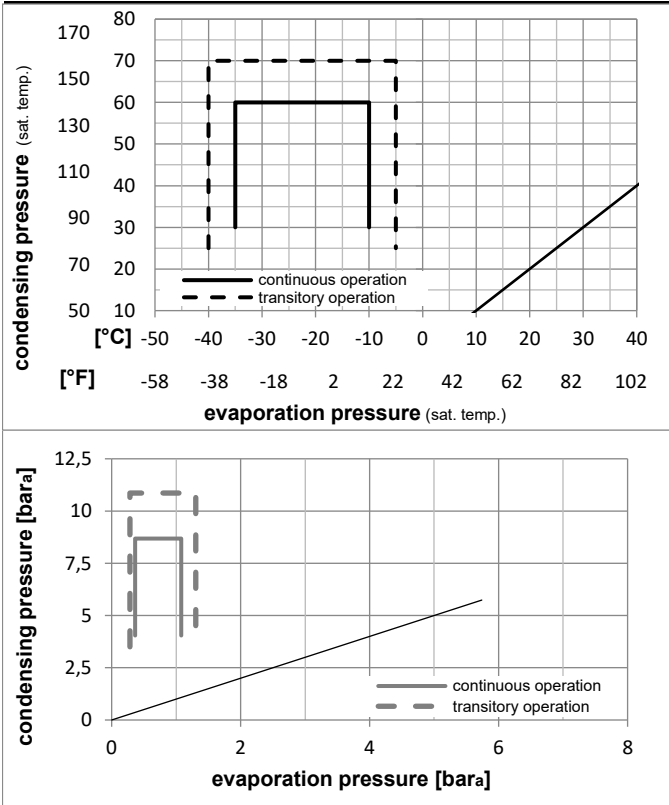

## Components

a1	e-PTC starter (220V, 250hm, 4.8mm)	103N0050
e	run capacitor (4μF, 4.8mm)	117-7119
b	plastic cover	103N2010
d	cord relief	103N1010
	bracket for run capacitor	117-0300
	screw M4x8mm	117-0301

## Alternative components

b	plastic cover	103N2011
---	---------------	----------

## Model

Designation **TLES5.7KK.3 220-240V/50Hz** Conf. 4 Sales code: **102H4694**

## Optimization + standard conditions

R600a, 220V/50Hz, RSCR, static, VDE, EAC

	Evaporating pressure (saturation temperature)				Condensing pressure (saturation temperature)			Return gas temp.			Liquid temp.			Cooling capacity			COP	EER	Power consumption			
	pe	pc	RGT	Tliq	[W]	[Btu/h]	[kcal/h]	[W/W]	[Btu/Wh]	[kcal/Wh]	P1	I	m	[W]	[A]	[kg/h]						
[°C]	-23	54	32	32	92,0	314	79,2	1,37	4,68	1,18	67,2	0,49	0,99									
[°F]	-10	130	90	90																ASHRAE LBP		
	-25	55	32	55	68,8	235	59,2	1,06	3,63	0,92	64,7	0,48	0,90							cecomaf LBP		
	-35	40	20	40	48,2	165	41,5	0,96	3,28	0,83	50,2	0,43	0,59							EN12900 LBP		
	-23	49	4,4	49	75,5	258	65,0	1,15	3,94	0,99	65,5	0,48	1,10							ARI540 LBP		
	-10	120	40	120																		
	-23	41	32	32	100,6	344	86,6	1,61	5,49	1,38	62,6	0,47	1,08							AHAM LBP		
	-10	105	90	90																		
	-35	45	32	45	45,5	155	39,1	0,91	3,09	0,78	50,2	0,42	0,54							opt		
	-31	113	90	113																		

## Performance tables

R600a, 220V/50Hz, RSCR, static, VDE, EAC

	pe		Cooling capacity			COP	EER	P1			I	m
	[°C]	[°F]	[W]	[Btu/h]	[kcal/h]	[W/W]	[Btu/Wh]	[kcal/Wh]	[W]	[A]	[kg/h]	
[°C / °F]	-35	-31	45,5	155	39,1	0,91	3,09	0,78	50,2	0,42	0,54	
cond. pressure	-30	-22	61,5	210	52,9	1,10	3,74	0,94	56,1	0,45	0,73	
pc= 45/113	-25	-13	81,0	277	69,7	1,30	4,46	1,12	62,1	0,47	0,96	
return gas temp.	-23	-10	88,5	302	76,2	1,38	4,71	1,19	64,2	0,48	1,05	
RGT= 32/90	-20	-4	104,5	357	89,9	1,53	5,21	1,31	68,5	0,49	1,25	
liquid temp	-15	5	132,4	452	113,9	1,75	5,98	1,51	75,6	0,52	1,58	
Tliq= 45/113	-10	14	165,2	564	142,2	1,97	6,73	1,70	83,8	0,55	1,98	
[°C / °F]	-35	-31	36,8	126	31,7	0,76	2,58	0,65	48,7	0,42	0,48	
cond. pressure	-30	-22	51,2	175	44,1	0,90	3,08	0,78	56,8	0,45	0,67	
pc= 55/131	-25	-13	68,8	235	59,2	1,06	3,63	0,92	64,7	0,48	0,90	
return gas temp	-23	-10	75,6	258	65,0	1,12	3,83	0,97	67,4	0,49	0,99	
RGT= 32/90	-20	-4	90,0	307	77,4	1,24	4,22	1,06	72,8	0,51	1,18	
liquid temp	-15	5	115,3	394	99,2	1,42	4,84	1,22	81,4	0,54	1,51	
Tliq= 55/131	-10	14	145,3	496	125,0	1,60	5,46	1,38	90,8	0,57	1,91	



# TL Compressors

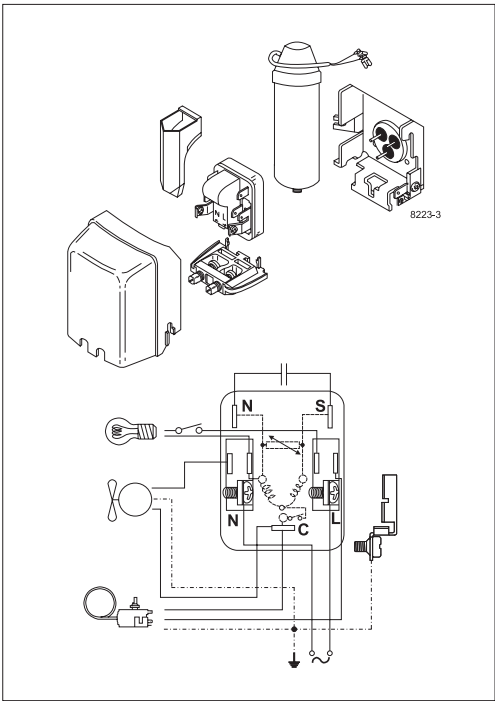
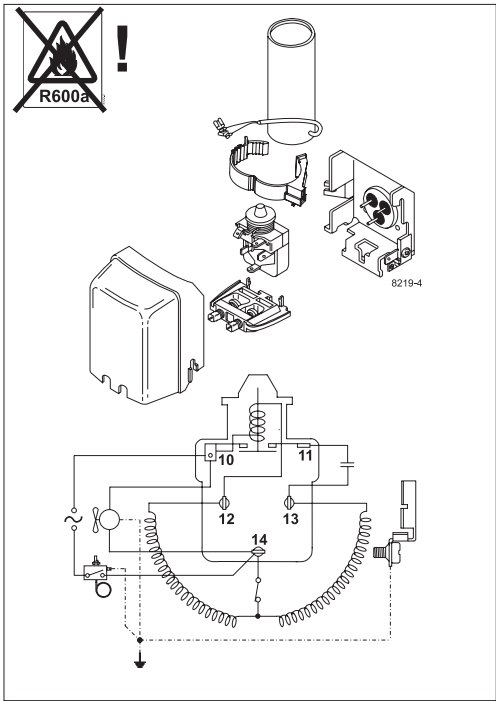



## Service/Repair – R600a, R290



8545

## Brazing on Suction Connectors (Direct Intake)

representative image



**! max. 150°C/302°F !  
at socket**  
brazing solder: phosphor (LP7) or silver

Refer to Product Bulletin:  
**Brazing on Suction Connectors  
(Compressors with Direct Suction Intake)**

Secop accepts no responsibility for possible errors in catalogs, brochures, and other printed material. Secop reserves the right to alter its products without notice. This also applies to products already on order provided that such alterations can be made without subsequential changes being necessary to specifications already agreed. All trademarks in this material are the property of the respective companies. Secop and the Secop logotype are trademarks of Secop GmbH. All rights reserved. [www.secop.com](http://www.secop.com)