

Single Pack NLE9KTK 220-240V 50/60Hz RSIR

Codice Imballo Singolo: **195B4563**

Posizione	Titolo	Codice	Quantità
1	Compressor NLE9KTK	105H6071	1
2	PTC starting device (220V, 250hm, 4.8mm)	103N0018	1
3	Cord relief	103N1010	1
4	Protection screen for PTC	103N0476	1
5	Cover	103N2010	1
6	Bolt joint for one compressor M6 ø16mm	118-1917	1

Secop GmbH • Lise-Meitner-Straße 29 • 24941 Flensburg, Germany • Tel: +49 46149410 • www.secop.com

Secop non si assume alcuna responsabilità per eventuali errori presenti in cataloghi, brochure e altro materiale stampato. Secop si riserva il diritto di modificare i propri prodotti senza preavviso. Ciò vale anche per i prodotti già ordinati, a condizione che tali modifiche possano essere apportate senza che siano necessarie modifiche successive alle specifiche già concordate. Tutti i marchi presenti in questo materiale sono di proprietà delle rispettive aziende. Secop e il logo Secop sono marchi di Secop GmbH. Tutti i diritti sono riservati.

Model

Designation	NLE9KTK	220-240V/50Hz 1~ 220-240V/60Hz 1~	Sales code:	105H6071
-------------	----------------	--	-------------	-----------------

Compressor design

Oil type	Mineral	Refrigerant(s)	R600a
Oil viscosity	15cST	Displacement	8,35cm ³ / 0,51cu.in
Oil quantity	300cm ³ / 10,1fl.oz	Compressors on pallet	80
Refr. charge - tech. limit	150g / 5,3oz		
Free gas volume comp.	2360cm ³ / 79,8fl.oz		
Weight	10kg / 22lbs		
Motor protection	1# internal		
Winding resistance main	14,9Ω (at 25°C)		
Winding resistance aux	17,9Ω (at 25°C)		
Max. winding temp.	125°C / 257°F		
Max. discharge temp.	130°C / 266°F		



General - Configurations with NLE9KTK

	Conf. 1	Conf. 2	Conf. 3
Motorconfiguration	RSIR	RSCR	RSCR
Power supply (nominal)	220-240V/50Hz	220-240V/50Hz	220-240V/60Hz
Number of phases	1	1	1
Voltage range	187-254V	187-254V	198-253V
Approvals	VDE	VDE	VDE
Starting torque	LST	LST	LST
Note	- / -		

Applications with NLE9KTK

	Conf. 1	Conf. 2	Conf. 3
Refrigerant	R600a	R600a	R600a
Application	LBP	LBP	LBP
System cooling	static	static	static
Hot gas defrost	- / -	- / -	- / -
Long interval pull down	- / -	- / -	- / -

Electrical data - Configurations with NLE9KTK

	Conf. 1	Conf. 2	Conf. 3
Starting device type	PTC	PTC	PTC
Run capacitor	- / -	4μF	4μF
Start capacitor	- / -	- / -	- / -
LRA (locked rotor amps / 4s)	5A	5A	5A
RLA (rated load amps / 1s)	0,9A	0,9A	0,9A
Cut in current	9,4A	9,4A	9,4A

Model

Designation

NLE9KTK

220-240V/50Hz 1~ 220-240V/60Hz 1~

Sales code:

105H6071

Compressor dimensions

Housing	A Height	197mm / 7,76in
	B Height	191mm / 7,52in
	C Length shell	205mm / 8,07in
	D Length w. cover	254mm / 10in
	E Width	166mm / 6,54in

Connectors		Suction	Discharge	Process
		X	Y	Z
Diameter	[mm]	øi 6,11-6,29	øi 5,12-5,22	øi 6,11-6,29
	(i:inside, o:outside) [in]	øi 0,24-0,25	øi 0,2-0,21	øi 0,24-0,25
Material		copper	copper	copper
Horizontal angle	±2°	0°	0°	0°
Vertical angle	±2°	15°	35°	155°
Position l/h/w	[mm]	126/76/78	133/103/54	-107/94/72
	[in]	4,9/3/3,1	5,2/4/2,1	-4,2/3,7/2,8
Straight tube l.	[mm]	12	12	12
	[in]	0,5	0,5	0,5

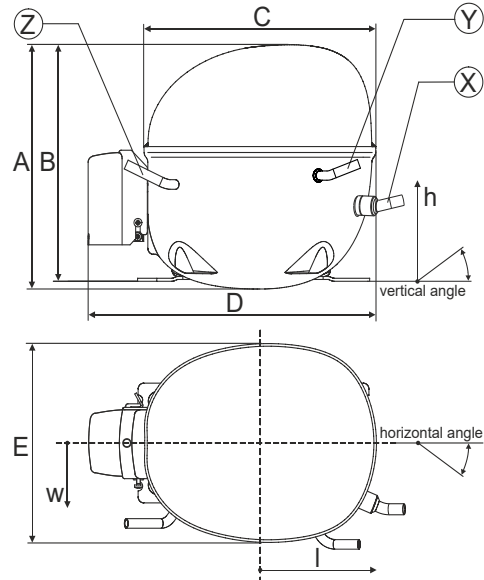

Compressor fixation

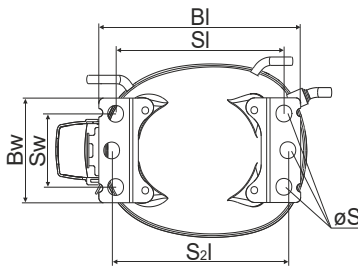

Baseplate	[mm]	[inch]
Bi	204	8.03
Bw	100	3.94

Small holes	[mm]	[inch]
Si	170	6.7
Sw	70	2.76
S2l	178	7
øS	ø 16	ø 0.63

Bolt joint

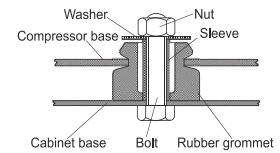

Snap-on

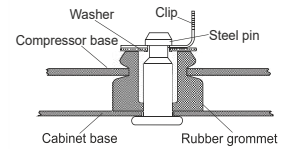

Mounting accessories

	one comp.	multi pack
Bolt joint M6 ø16mm	118-1917	118-1918
Bolt joint ø1/4" ø16mm	118-1946	
Snap-on ø7,3 ø16mm	118-1947	118-1919

Model

Designation	NLE9KTK	220-240V/50Hz	Conf. 1	Sales code:	105H6071
-------------	----------------	----------------------	----------------	-------------	-----------------

Configuration

Motorconfiguration	RSIR
Power supply (nominal)	220-240V/50Hz 1~
Refrigerant	R600a
Application	LBP
Voltage range	187-254V
Starting torque	LST
Approvals	VDE

Electrical accessories / wiring diagram

RSIR

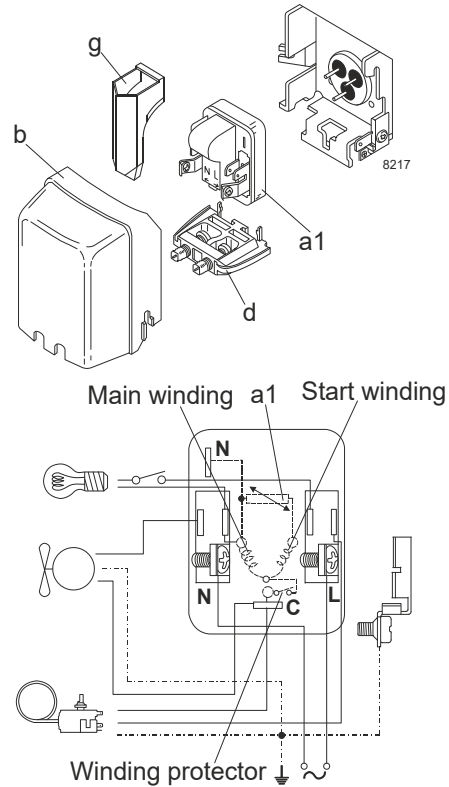

Ambient temperatures / system cooling

Ambient temperature min.:	10°C / 50°F
Ambient temperature max.:	43°C / 110°F

System cooling (n/a: outside limits)			
T ambient	LBP	MBP	HBP
32°C / 90°F	static	n/a	n/a
38°C / 100°F	static	n/a	n/a
43°C / 110°F	static	n/a	n/a

Operation pressure range

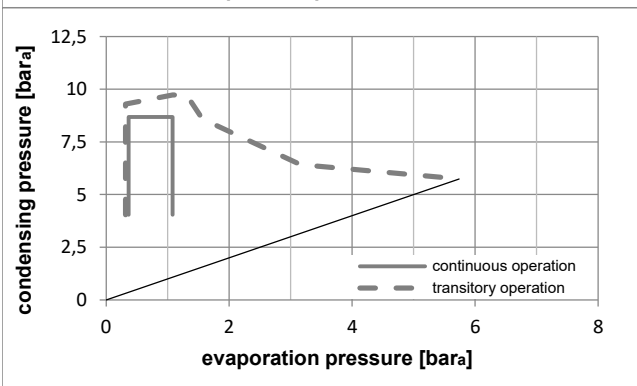
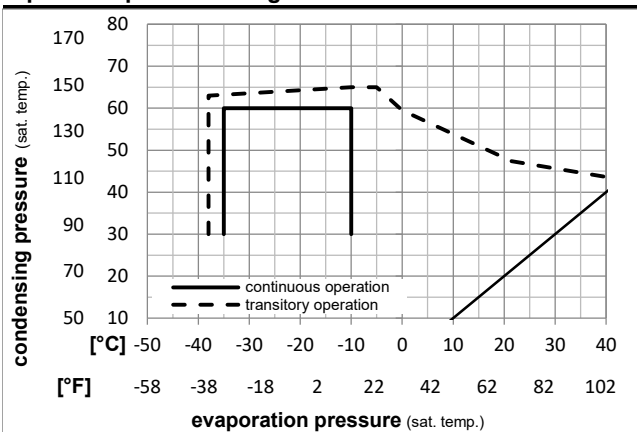

Components

a1	PTC starter (220V, 250hm, 4.8mm)	103N0018
b	plastic cover	103N2010
d	cord relief	103N1010
g	protection screen for PTC	103N0476

Alternative components

a1	PTC starter (220V, 250hm, 6.3mm)	103N0011
b	plastic cover	103N2011
d	cord relief	103N1010
g	protection screen for PTC	103N0476

Model

Designation	NLE9KTK	220-240V/50Hz	Conf. 1	Sales code:	105H6071
-------------	----------------	----------------------	----------------	-------------	-----------------

Optimization + standard conditions

R600a, 220V/50Hz, RSIR, static, VDE

		Evaporating pressure (saturation temperature)				Condensing pressure (saturation temperature)						Power consumption							
						Return gas temp.						Current consumption							
						Liquid temp.						Ref. mass flow							
						Cooling capacity						COP			EER	P1	I	m	
		pe	pc	RGT	Tliq	[W]	[Btu/h]	[kcal/h]	[W/W]	[Btu/Wh]	[kcal/Wh]	[W]	[A]	[kg/h]					
[°C]	-23,3	54,4	32,2	32,2	131,0	447	112,7	1,32	4,52	1,14	98,9	0,76	1,41	ASHRAE LBP					
[°F]	-10	130	90	90															
[°C]	-25	55	32	55	98,0	335	84,4	1,03	3,52	0,89	95,0	0,75	1,28	cecomaf LBP					
[°F]	-13	131	89,6	131															
[°C]	-35	40	20	40	63,5	217	54,7	0,90	3,07	0,77	70,8	0,66	0,77	EN12900 LBP					
[°F]	-31	104	68	104															
[°C]	-23,3	48,9	4,44	48,9	106,5	364	91,6	1,08	3,70	0,93	98,4	0,76	1,56	ARI540 LBP					
[°F]	-10	120	40	120															
[°C]	-23,3	40,6	32,2	32,2	140,8	481	121,1	1,46	4,98	1,25	96,6	0,75	1,51	AHAM LBP					
[°F]	-10	105	90	90															
[°C]	-35	45	32	45	61,8	211	53,2	0,86	2,92	0,74	72,3	0,67	0,73	opt					
[°F]	-31	113	89,6	113															

Performance tables

R600a, 220V/50Hz, RSIR, static, VDE

	pe	Cooling capacity			COP			EER			P1	I	m
	[°C]	[°F]	[W]	[Btu/h]	[kcal/h]	[W/W]	[Btu/Wh]	[kcal/Wh]	[W]	[A]	[kg/h]		
[°C / °F]	-35	-31	61,8	211	53,2	0,86	2,92	0,74	72,3	0,67	0,73		
cond. pressure	-30	-22	84,4	288	72,6	1,03	3,51	0,88	82,2	0,70	1,00		
pc= 45/113	-25	-13	113,0	386	97,3	1,21	4,12	1,04	93,6	0,74	1,35		
return gas temp.	-23,3	-10	124,3	425	107,0	1,27	4,34	1,09	97,7	0,75	1,48		
RGT= 32/90	-20	-4	148,8	508	128,0	1,40	4,79	1,21	106,0	0,78	1,77		
liquid temp	-15	5	192,8	658	165,9	1,62	5,55	1,40	118,7	0,81	2,30		
Tliq= 45/113	-10	14	246,2	841	211,9	1,88	6,41	1,62	131,2	0,85	2,95		
[°C / °F]	-35	-31	54,3	186	46,8	0,72	2,45	0,62	75,7	0,67	0,71		
cond. pressure	-30	-22	73,8	252	63,5	0,88	2,99	0,75	84,3	0,71	0,96		
pc= 55/131	-25	-13	98,0	335	84,4	1,03	3,52	0,89	95,0	0,75	1,28		
return gas temp	-23,3	-10	107,6	368	92,6	1,09	3,71	0,93	99,1	0,76	1,40		
RGT= 32/90	-20	-4	128,3	438	110,4	1,20	4,08	1,03	107,3	0,78	1,68		
liquid temp	-15	5	165,7	566	142,6	1,37	4,69	1,18	120,6	0,82	2,17		
Tliq= 55/131	-10	14	211,2	721	181,7	1,57	5,37	1,35	134,3	0,86	2,77		

Model

Designation	NLE9KTK	220-240V/50Hz	Conf. 2	Sales code:	105H6071
-------------	----------------	----------------------	----------------	-------------	-----------------

Configuration

Motorconfiguration	RSCR
Power supply (nominal)	220-240V/50Hz 1~
Refrigerant	R600a
Application	LBP
Voltage range	187-254V
Starting torque	LST
Approvals	VDE

Electrical accessories / wiring diagram

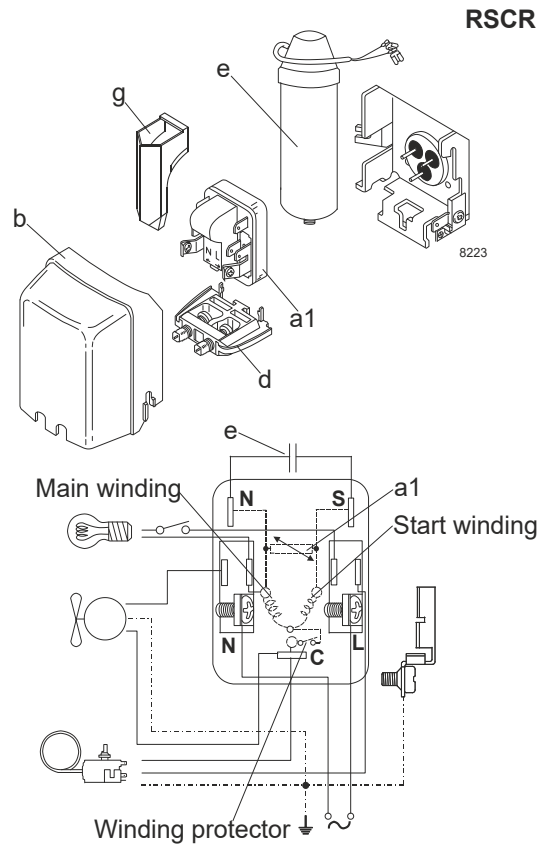

Ambient temperatures / system cooling

Ambient temperature min.:	10°C / 50°F
Ambient temperature max.:	43°C / 110°F

System cooling (n/a: outside limits)			
T ambient	LBP	MBP	HBP
32°C / 90°F	static	n/a	n/a
38°C / 100°F	static	n/a	n/a
43°C / 110°F	static	n/a	n/a

Operation pressure range

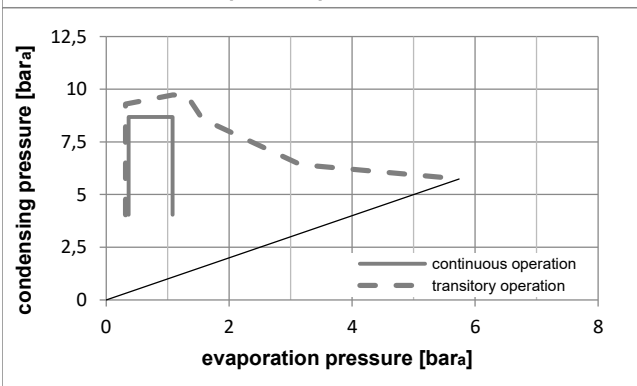
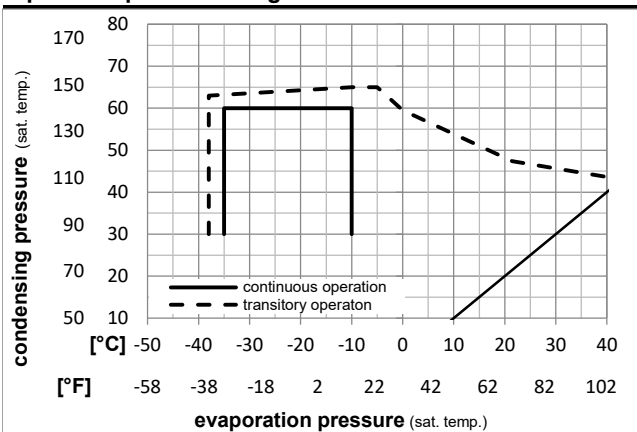

Components

a1	PTC starter (220V, 250ohm, 4.8mm)	103N0021
e	run capacitor (4µF, 4.8mm)	117-7119
b	plastic cover	103N2010
d	cord relief	103N1010
g	protection screen for PTC	103N0476
	bracket for run capacitor	117-0300

Alternative components

a1	PTC starter (220V, 250ohm, 6.3mm)	103N0016
e	run capacitor (4µF, 6.3mm)	117-7117
b	plastic cover	103N2011
	screw M4x8mm	117-0301

Model

Designation	NLE9KTK	220-240V/50Hz	Conf. 2	Sales code:	105H6071
-------------	----------------	----------------------	----------------	-------------	-----------------

Optimization + standard conditions

R600a, 220V/50Hz, RSCR, static, VDE

		Evaporating pressure (saturation temperature)				Condensing pressure (saturation temperature)						Power consumption			
						Return gas temp.			Liquid temp.			Current consumption			Ref. mass flow
						Cooling capacity			COP	EER	P1			I	m
		pe	pc	RGT	Tliq	[W]	[Btu/h]	[kcal/h]	[W/W]	[Btu/Wh]	[kcal/Wh]	[W]	[A]	[kg/h]	
[°C]	-23	54,4	32,2	32,2	132,3	452	113,8	1,38	4,71	1,19	96,0	0,74	1,42	ASHRAE LBP	
[°F]	-10	130	90	90											
[°C]	-25	55	32	55	99,0	338	85,2	1,07	3,67	0,92	92,2	0,73	1,29	cecomaf LBP	
[°F]	-13	131	89,6	131											
[°C]	-35	40	20	40	64,2	219	55,2	0,93	3,19	0,80	68,6	0,64	0,78	EN12900 LBP	
[°F]	-31	104	68	104											
[°C]	-23	48,9	4,44	48,9	107,5	367	92,6	1,13	3,85	0,97	95,4	0,73	1,57	ARI540 LBP	
[°F]	-10	120	40	120											
[°C]	-23	40,6	32,2	32,2	142,2	486	122,4	1,52	5,18	1,31	93,7	0,73	1,53	AHAM LBP	
[°F]	-10	105	90	90											
[°C]	-35	45	32	45	62,5	213	53,8	0,89	3,04	0,77	70,2	0,65	0,74	opt	
[°F]	-31	113	89,6	113											

Performance tables

R600a, 220V/50Hz, RSCR, static, VDE

	pe		Cooling capacity			COP	EER	P1	I	m	
	[°C]	[°F]	[W]	[Btu/h]	[kcal/h]	[W/W]	[Btu/Wh]	[kcal/Wh]	[W]	[A]	[kg/h]
[°C / °F]	-35	-31	62,5	213	53,8	0,89	3,04	0,77	70,2	0,65	0,74
cond. pressure	-30	-22	85,2	291	73,4	1,07	3,65	0,92	79,7	0,68	1,01
pc= 45/113	-25	-13	114,1	390	98,2	1,26	4,29	1,08	90,8	0,72	1,36
return gas temp.	-23	-10	125,6	429	108,1	1,32	4,52	1,14	94,8	0,73	1,50
RGT= 32/90	-20	-4	150,3	513	129,3	1,46	4,99	1,26	102,8	0,75	1,79
liquid temp	-15	5	194,7	665	167,6	1,69	5,78	1,46	115,2	0,79	2,33
Tliq= 45/113	-10	14	248,7	849	214,0	1,95	6,67	1,68	127,3	0,82	2,98
[°C / °F]	-35	-31	54,9	187	47,2	0,75	2,55	0,64	73,5	0,65	0,71
cond. pressure	-30	-22	74,5	254	64,1	0,91	3,11	0,78	81,7	0,69	0,97
pc= 55/131	-25	-13	99,0	338	85,2	1,07	3,67	0,92	92,2	0,73	1,29
return gas temp	-23	-10	108,7	371	93,5	1,13	3,86	0,97	96,1	0,74	1,42
RGT= 32/90	-20	-4	129,6	443	111,5	1,24	4,25	1,07	104,1	0,76	1,69
liquid temp	-15	5	167,3	571	144,0	1,43	4,88	1,23	117,0	0,80	2,19
Tliq= 55/131	-10	14	213,3	728	183,6	1,64	5,59	1,41	130,3	0,83	2,80

Model

Designation	NLE9KTK	220-240V/60Hz	Conf. 3	Sales code:	105H6071
-------------	----------------	----------------------	----------------	-------------	-----------------

Configuration

Motorconfiguration	RSCR
Power supply (nominal)	220-240V/60Hz 1~
Refrigerant	R600a
Application	LBP
Voltage range	198-253V
Starting torque	LST
Approvals	VDE

Electrical accessories / wiring diagram

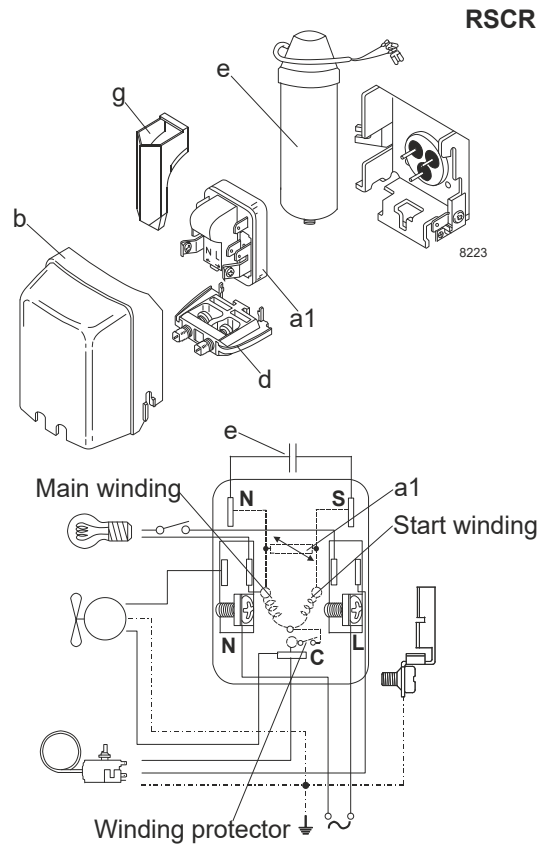

Ambient temperatures / system cooling

Ambient temperature min.:	10°C / 50°F
Ambient temperature max.:	38°C / 101°F

System cooling (n/a: outside limits)			
T ambient	LBP	MBP	HBP
32°C / 90°F	static	n/a	n/a
38°C / 100°F	static	n/a	n/a
43°C / 110°F	fan 1,5m/s	n/a	n/a

Operation pressure range

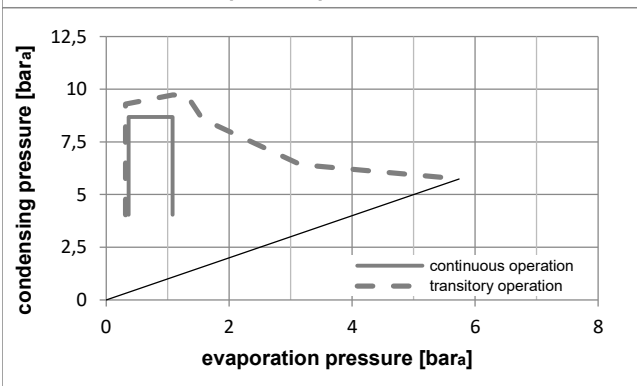
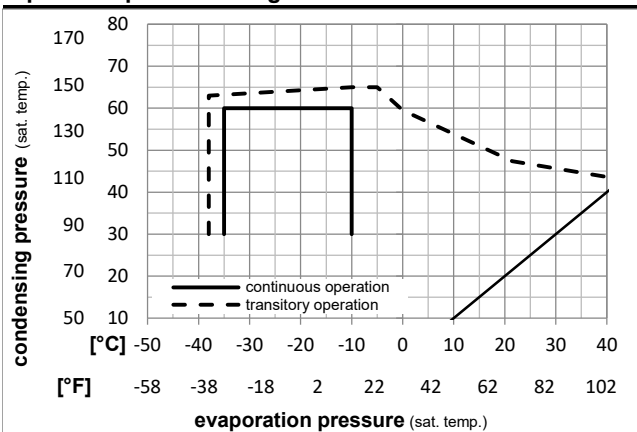

Components

a1	PTC starter (220V, 250hm, 4.8mm)	103N0021
e	run capacitor (4μF, 4.8mm)	117-7119
b	plastic cover	103N2010
d	cord relief	103N1010
g	protection screen for PTC	103N0476
	bracket for run capacitor	117-0300

Alternative components

a1	PTC starter (220V, 250hm, 6.3mm)	103N0016
e	run capacitor (4μF, 6.3mm)	117-7117
b	plastic cover	103N2011
	screw M4x8mm	117-0301

Model

Designation **NLE9KTK 220-240V/60Hz** Conf. 3 Sales code: **105H6071**

Optimization + standard conditions

R600a, 220V/60Hz, RSCR, static, VDE

Evaporating pressure (saturation temperature)														
Condensing pressure (saturation temperature)														
Return gas temp.														
Liquid temp.														
Cooling capacity														
COP														
EER														
Power consumption														
Current consumption														
Ref. mass flow														
	pe	pc	RGT	Tliq	[W]	[Btu/h]	[kcal/h]	[W/W]	[Btu/Wh]	[kcal/Wh]	P1	I	m	
[°C]											[W]	[A]	[kg/h]	
	-23,3	54,4	32,2	32,2	151,9	519	130,7	1,29	4,41	1,11	117,7	0,90	1,63	ASHRAE LBP
[°F]	-10	130	90	90										
	-25	55	32	55	113,7	388	97,9	1,01	3,44	0,87	113,1	0,89	1,48	cecomaf LBP
[°F]	-13	131	89,6	131										
	-35	40	20	40	73,7	252	63,4	0,88	2,99	0,75	84,2	0,79	0,90	EN12900 LBP
[°F]	-31	104	68	104										
	-23,3	48,9	4,44	48,9	123,5	422	106,3	1,06	3,60	0,91	117,0	0,90	1,80	ARI540 LBP
[°F]	-10	120	40	120										
	-23,3	40,6	32,2	32,2	163,3	558	140,5	1,42	4,85	1,22	114,9	0,89	1,75	AHAM LBP
[°F]	-10	105	90	90										
	-35	45	32	45	71,7	245	61,7	0,83	2,85	0,72	86,1	0,79	0,85	opt
[°F]	-31	113	89,6	113										

Performance tables

R600a, 220V/60Hz, RSCR, static, VDE

	pe	Cooling capacity			COP			EER			P1	I	m
	[°C]	[°F]	[W]	[Btu/h]	[kcal/h]	[W/W]	[Btu/Wh]	[kcal/Wh]	[W]	[A]	[kg/h]		
[°C / °F]	-35	-31	71,7	245	61,7	0,83	2,85	0,72	86,1	0,79	0,85		
cond. pressure	-30	-22	97,9	334	84,3	1,00	3,42	0,86	97,8	0,84	1,16		
pc= 45/113	-25	-13	131,1	448	112,8	1,18	4,02	1,01	111,4	0,88	1,56		
return gas temp.	-23,3	-10	144,2	492	124,1	1,24	4,23	1,07	116,3	0,89	1,72		
RGT= 32/90	-20	-4	172,6	589	148,5	1,37	4,67	1,18	126,1	0,92	2,06		
liquid temp	-15	5	223,7	764	192,5	1,58	5,41	1,36	141,3	0,97	2,67		
Tliq= 45/113	-10	14	285,6	975	245,8	1,83	6,25	1,57	156,1	1,01	3,42		
[°C / °F]	-35	-31	63,0	215	54,2	0,70	2,39	0,60	90,1	0,80	0,82		
cond. pressure	-30	-22	85,6	292	73,6	0,85	2,91	0,73	100,3	0,85	1,11		
pc= 55/131	-25	-13	113,7	388	97,9	1,01	3,44	0,87	113,1	0,89	1,48		
return gas temp	-23,3	-10	124,8	426	107,4	1,06	3,62	0,91	117,9	0,90	1,63		
RGT= 32/90	-20	-4	148,8	508	128,1	1,17	3,98	1,00	127,7	0,93	1,94		
liquid temp	-15	5	192,2	656	165,4	1,34	4,57	1,15	143,6	0,98	2,52		
Tliq= 55/131	-10	14	245,0	837	210,8	1,53	5,23	1,32	159,8	1,02	3,22		



8238-20

NL Compressors

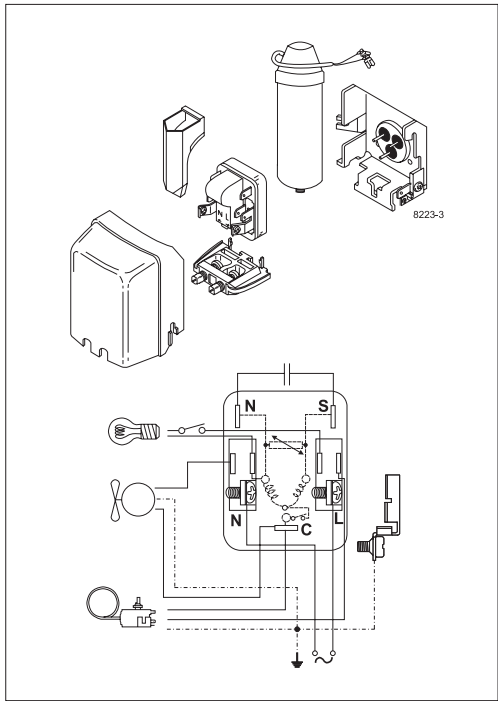
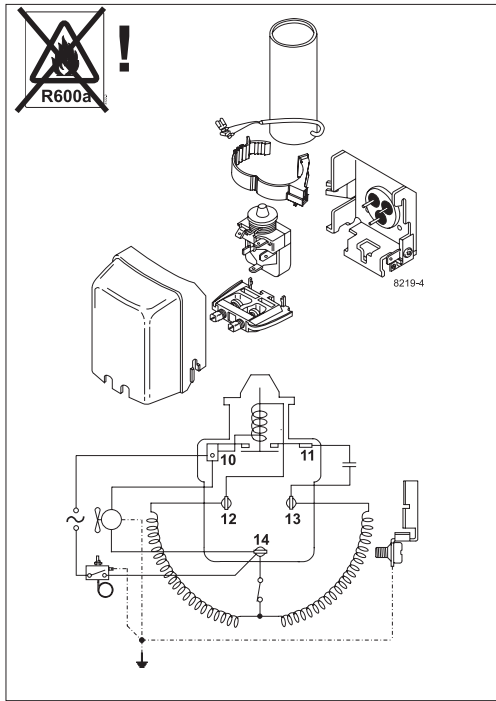



Service/Repair – R600a, R290



8545

Brazing on Suction Connectors (Direct Intake)

representative image



**! max. 150°C/302°F !
at socket**
brazing solder: phosphor (LP7) or silver

Refer to Product Bulletin:
**Brazing on Suction Connectors
(Compressors with Direct Suction Intake)**

Secop accepts no responsibility for possible errors in catalogs, brochures, and other printed material. Secop reserves the right to alter its products without notice. This also applies to products already on order provided that such alterations can be made without subsequential changes being necessary to specifications already agreed. All trademarks in this material are the property of the respective companies. Secop and the Secop logotype are trademarks of Secop GmbH. All rights reserved. www.secop.com