

Single Pack NLE11KTK 115-127V 60Hz RSCR

Codice Imballo Singolo: **195B4602**

Posizione	Titolo	Codice	Quantità
1	Compressor NLE11KTK	105H5942	1
2	PTC starting device (115V, 50hm, 6.3mm)	103N0027	1
3	Run capacitor (15µF 190V, 6.3mm)	117-7118	1
4	Cord relief	103N1010	1
5	Cover	103N2010	1
6	Snap-on in quantities ø7,3 ø16mm	118-1919	1

Secop GmbH • Lise-Meitner-Straße 29 • 24941 Flensburg, Germany • Tel: +49 46149410 • www.secop.com

Secop non si assume alcuna responsabilità per eventuali errori presenti in cataloghi, brochure e altro materiale stampato. Secop si riserva il diritto di modificare i propri prodotti senza preavviso. Ciò vale anche per i prodotti già ordinati, a condizione che tali modifiche possano essere apportate senza che siano necessarie modifiche successive alle specifiche già concordate. Tutti i marchi presenti in questo materiale sono di proprietà delle rispettive aziende. Secop e il logo Secop sono marchi di Secop GmbH. Tutti i diritti sono riservati.

NLE11KTK Energy-optimized Tropical Compressor R600a 115-127V 60Hz

General

Code number	105H5942
Approvals	UL984
Compressors on pallet	80

Application

Application	LBP/MBP			
	Hz	50	60	
Evaporating temperature	°F	-	LBP: -20 to 10 MBP: 0 to 45	
Voltage range	V	-	95 - 135	
Max. condensing temperature continuous (short)	°F	-	140 (158)	
Max. winding temperature continuous (short)	°F	-	257 (275)	

Cooling requirements

Frequency	Hz	50			60		
		LBP	MBP	HBP	LBP	MBP	HBP
90°F		-	-	-	S	S	-
100°F		-	-	-	S	S	-
110°F		-	-	-	S	S	-

Remarks on application:
Fan and other accessories near the compressor have to be of "n" type protection according to IEC 79-15. MBP & commercial application only with timer function for ensuring pressure equalization, e.g. Danfoss Electronic Thermostate type ETC1.

Motor

Motor type	RSIR/RSCR		
LRA (rated after 4 sec. UL984), HST LST	A	-	28.0
Cut in Current, HST LST	A	-	18.8
Resistance, main start winding (77°F)	Ω	1.9	3.9

Design

Displacement	cu.in	0.68
Oil quantity (type)	fl.oz.	10.14 (polyolester)
Maximum refrigerant charge	oz.	5.3
Free gas volume in compressor	fl.oz.	79.7
Weight without electrical equipment	lbs.	22.0

Dimensions

Height	inch	A	7.76
		B	7.52
		B1	-
		B2	-
Suction connector	location, I.D. in. angle	C	0.252-0.259 15°
	material comment		Copper Rubber plug
Process connector	location, I.D. in. angle	D	0.252-0.259 25°
	material comment		Copper Rubber plug
Discharge connector	location, I.D. in. angle	E	0.202-0.205 35°
	material comment		Copper Rubber plug
Oil cooler connector	location, I.D. in. angle	F	-
	material comment		-

Remarks:

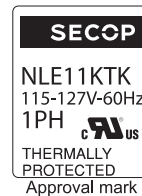
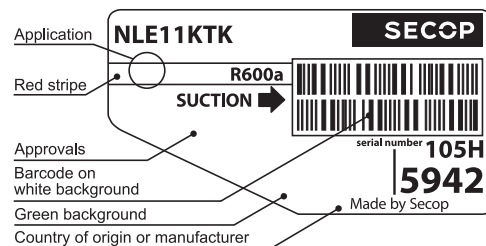

- S = Static cooling normally sufficient
- O = Oil cooling
- F₁ = Fan cooling 1.5 m/s
(compressor compartment temperature equal to ambient temperature)
- F₂ = Fan cooling 3.0 m/s necessary
- SG = Suction gas cooling normally sufficient
- = not applicable in this area

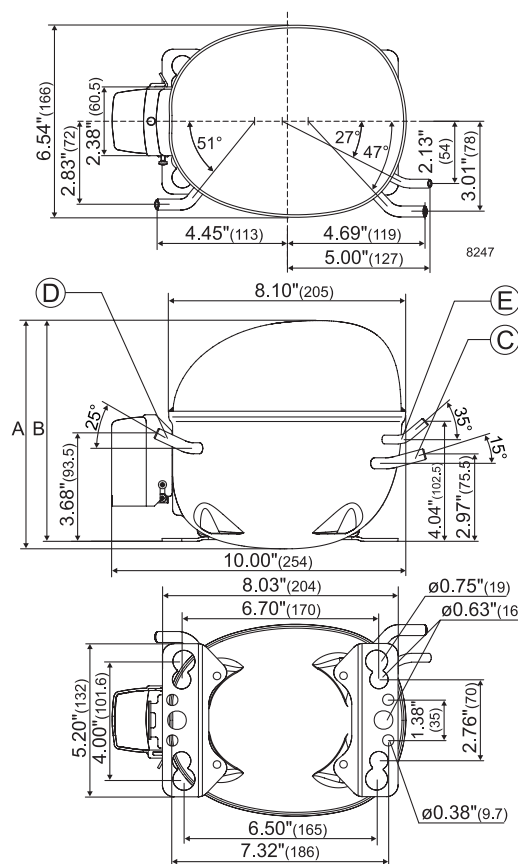

ASHRAE LBP

Static cooling 115V 60Hz, PTC consumption incl.

Evap. temp. in °F	-49	-40	-30	-20	-13	-10	0	10	20	30	40	45	50	59	68
Capacity in BTU/h			363	493	612	671	892	1165	1546	1884	2224	2396			
Power cons. in W			114	138	154	161	182	202	246	272	295	304			
Current cons. in A			2.35	2.45	2.52	2.55	2.66	2.77	3.03	3.21	3.36	3.52			
EER in BTU/Wh			3.18	3.57	3.97	4.17	4.90	5.77	6.28	6.93	7.54	7.88			

ASHRAE MBP

Static cooling 115V 60Hz, PTC consumption incl.

Evap. temp. in °F	-49	-40	-30	-20	-13	-10	0	10	20	30	40	45	50	59	68
Capacity in BTU/h			329	447	555	609	809	1057	1402	1708	2016	2171			
Power cons. in W			114	138	154	161	182	202	246	272	295	304			
Current cons. in A			2.35	2.45	2.52	2.55	2.66	2.77	3.03	3.21	3.36	3.52			
EER in BTU/Wh			2.89	3.24	3.61	3.78	4.45	5.23	5.70	6.28	6.83	7.14			

EN 12900 Household (CECOMAF)

Static cooling 115V 60Hz, PTC consumption incl.

Evap. temp. in °F	-49	-40	-30	-20	-13	-10	0	10	20	30	40	45	50	59	68
Capacity in W			88	119	148	162	215	281	372	453	535	575			
Power cons. in W			114	138	154	161	182	202	246	272	295	304			
Current cons. in A			2.35	2.45	2.52	2.55	2.66	2.77	3.03	3.21	3.36	3.52			
COP in W/W			0.77	0.86	0.96	1.00	1.18	1.39	1.51	1.67	1.81	1.89			

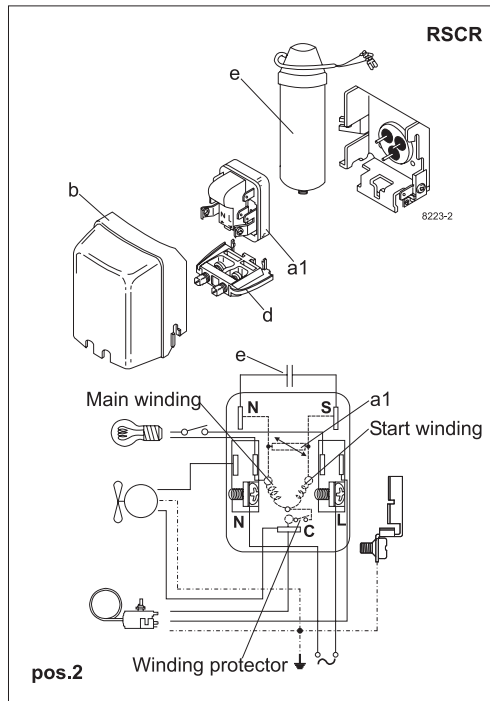
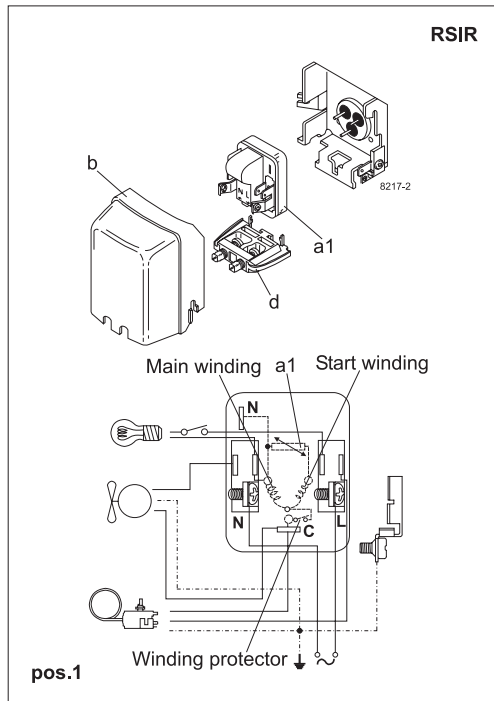

Accessories for	NLE11KTK	Figure	Code number
PTC starting device	1/4 in. spade connect.	a1	103N0026
	3/16 in. spade connect.	(pos.1)	103N0023
PTC starting device	1/4 in. spade connect.	a1	103N0027
	3/16 in. spade connect.	(pos.2)	103N0024
Cover		b	103N2011
Cord relief		d	103N1010
Run capacitor	1/4 in. spade connect.	e	117-7118
	15 µF (optional)		117-7120

Test conditions	ASHRAE LBP	ASHRAE MBP	EN 12900/CECOMAF
Condensing temp.	130°F	130°F	131°F
Ambient temp.	90°F	95°F	90°F
Suction gas temp.	90°F	95°F	90°F
Liquid temperature	90°F	115°F	131°F

Mounting accessories	Code number	
Bolt joint for one comp.	Ø: 5/8 in.	118-1917
Bolt joint in quantities	Ø: 5/8 in.	118-1918
Snap-on in quantities	Ø: 5/8 in.	118-1919

Secop accepts no responsibility for possible errors in catalogs, brochures, and other printed material. Secop reserves the right to alter its products without notice. This also applies to products already on order provided that such alterations can be made without subsequential changes being necessary to specifications already agreed. All trademarks in this material are the property of the respective companies. Secop and the Secop logotype are trademarks of Secop GmbH. All rights reserved. www.secop.com



NL Compressors





Service/Repair – R600a, R290



8545

Brazing on Suction Connectors (Direct Intake)

representative image



**! max. 150°C/302°F !
at socket**
brazing solder: phosphor (LP7) or silver

Refer to Product Bulletin:
**Brazing on Suction Connectors
(Compressors with Direct Suction Intake)**

Secop accepts no responsibility for possible errors in catalogs, brochures, and other printed material. Secop reserves the right to alter its products without notice. This also applies to products already on order provided that such alterations can be made without subsequential changes being necessary to specifications already agreed. All trademarks in this material are the property of the respective companies. Secop and the Secop logotype are trademarks of Secop GmbH. All rights reserved. www.secop.com