

Singolo Imballi



Single Pack GS34MLX 220-240V 50Hz CSCR

Codice Imballo Singolo: **195B4630**

Posizione	Titolo	Codice	Quantità
1	Compressor GS34MLX	107B0504	1
2	GS starting device (600mm)	117-7056	1
3	Bolt joint for one compressor M8 ø19mm	107B9150	1

Secop GmbH • Lise-Meitner-Straße 29 • 24941 Flensburg, Germany • Tel: +49 46149410 • www.secop.com

Secop non si assume alcuna responsabilità per eventuali errori presenti in cataloghi, brochure e altro materiale stampato. Secop si riserva il diritto di modificare i propri prodotti senza preavviso. Ciò vale anche per i prodotti già ordinati, a condizione che tali modifiche possano essere apportate senza che siano necessarie modifiche successive alle specifiche già concordate. Tutti i marchi presenti in questo materiale sono di proprietà delle rispettive aziende. Secop e il logo Secop sono marchi di Secop GmbH. Tutti i diritti sono riservati.

Model

Designation	GS34MLX	220-240V/50Hz 1~	Sales code:	107B0504
-------------	----------------	-------------------------	-------------	-----------------

Compressor design

Oil type	Polyolester	Refrigerant(s)	R404A, R452A, R507
Oil viscosity	46cST	Displacement	33,8cm ³ / 2,06cu.in
Oil quantity	906cm ³ / 30,6fl.oz	Compressors on pallet	48
Refr. charge - tech. limit	2000g / 70,5oz		
Free gas volume comp.	3540cm ³ / 119,7fl.oz		
Weight	22,3kg / 49,2lbs		
Motor protection	1# internal		
Winding resistance main	1,5Ω (at 25°C)		
Winding resistance aux	5,8Ω (at 25°C)		
Max. winding temp.			
Max. discharge temp.	120°C / 248°F		



General - Configurations with GS34MLX

	Conf. 1	Conf. 2	Conf. 3	Conf. 4
Motorconfiguration	CSCR	CSCR	CSCR	CSCR
Power supply (nominal)	220-240V/50Hz	220-240V/50Hz	220-240V/50Hz	220-240V/50Hz
Number of phases	1	1	1	1
Voltage range	198-254V	198-254V	198-254V	198-254V
Approvals	VDE, CCC, EAC	VDE, CCC, EAC		
Starting torque	HST	HST	HST	HST
Note	Cover, clamp, gasket: pre-assembled to compressor.			

Applications with GS34MLX

	Conf. 1	Conf. 2	Conf. 3	Conf. 4
Refrigerant	R404A	R452A	R448A	R449A
Application	MBP	MBP	MBP	MBP
System cooling	fan 3m/s	fan 3m/s	fan 3m/s	fan 3m/s
Hot gas defrost	OK	OK	OK	OK
Long interval pull down	OK	OK	OK	OK

Electrical data - Configurations with GS34MLX

	Conf. 1	Conf. 2	Conf. 3	Conf. 4
Starting device type	relay	relay	relay	relay
Run capacitor	20μF	20μF	20μF	20μF
Start capacitor	100μF	100μF	100μF	100μF
LRA (locked rotor amps / 4s)	46A	46A	46A	46A
RLA (rated load amps / 1s)	9,3A	9,3A	9,3A	9,3A
Cut in current	46A	46A	46A	46A

Model

Designation **GS34MLX** 220-240V/50Hz 1~ Sales code: **107B0504**

Compressor dimensions

Housing	A Height	279mm / 10,98in
	B Height	267mm / 10,51in
	C Length shell	224mm / 8,82in
	D Length w. cover	232mm / 9,13in
	E Width	173mm / 6,81in

Connectors		Suction	Discharge	Process
		X	Y	Z
Diameter	[mm]	øi 16,03-16,13	øi 6,45-6,55	øi 6,4-6,6
	(i:inside, o:outside) [in]	øi 0,63-0,64	øi 0,25-0,26	øi 0,25-0,26
Material		copper	copper	copper
Horizontal angle	±2°	0°	0°	0°
Vertical angle	±2°	90°	71°	90°
Position l/h/w	[mm]	-95/234/-84	-105/84/-84	95/234/84
	[in]	-3,7/9,2/-3,3	-4,1/3,3/-3,3	3,7/9,2/3,3
Straight tube l.	[mm]	18	19	15
	[in]	0,7	0,7	0,6

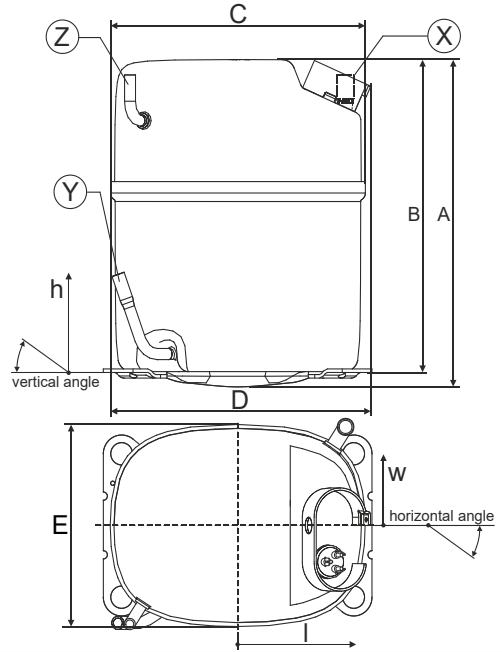

Compressor fixation

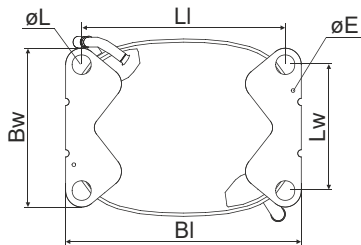

Baseplate	[mm]	[inch]
BI	235	9.25
Bw	154	6.06
øE	ø 3.6	ø 0.14

Large holes	[mm]	[inch]
LI	203	7.99
LW	122	4.80
øL	ø 19	ø 0.75

Bolt joint

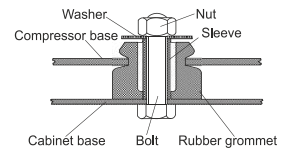

Mounting accessories

Bolt joint | M8 | ø19mm one comp. 107B9150

Model

Designation	GS34MLX	220-240V/50Hz	Conf. 1	Sales code:	107B0504
-------------	----------------	----------------------	----------------	-------------	-----------------

Configuration

Motorconfiguration	CSCR
Power supply (nominal)	220-240V/50Hz 1~
Refrigerant	R404A
Application	MBP
Voltage range	198-254V
Starting torque	HST
Approvals	VDE
	CCC
	EAC

Electrical accessories / wiring diagram

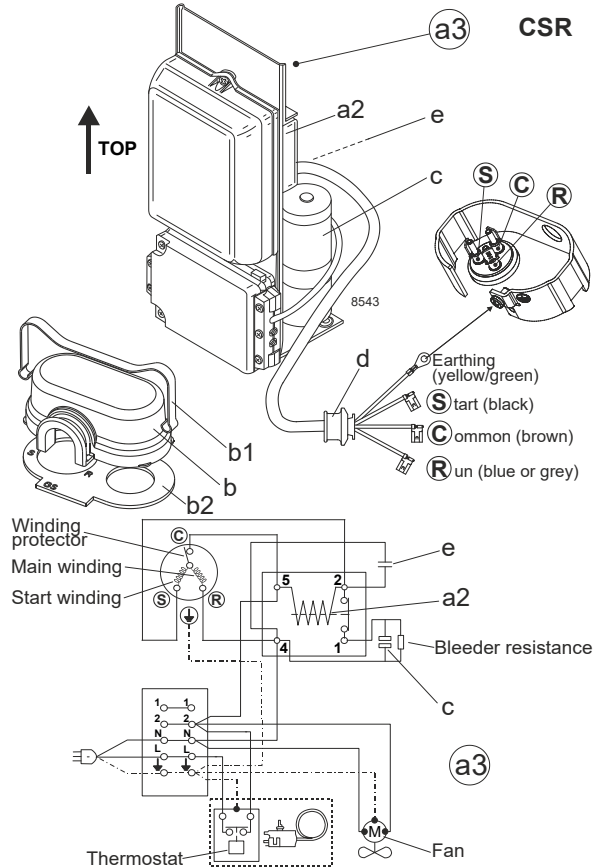

Ambient temperatures / system cooling

Ambient temperature min.:	10°C / 50°F
Ambient temperature max.:	43°C / 110°F

System cooling (n/a: outside limits)

T ambient	LBP	MBP	HBP
32°C / 90°F	n/a	fan 3m/s	n/a
38°C / 100°F	n/a	fan 3m/s	n/a
43°C / 110°F	n/a	fan 3m/s	n/a

Operation pressure range

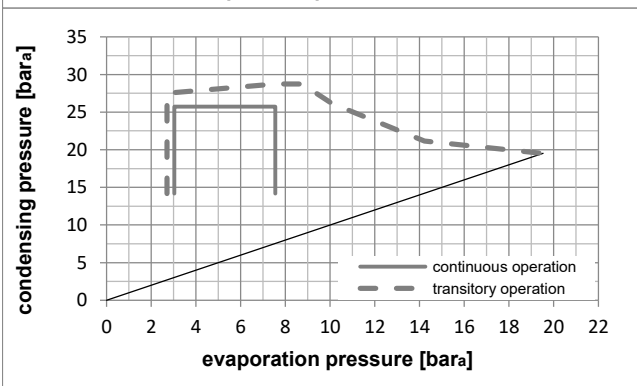
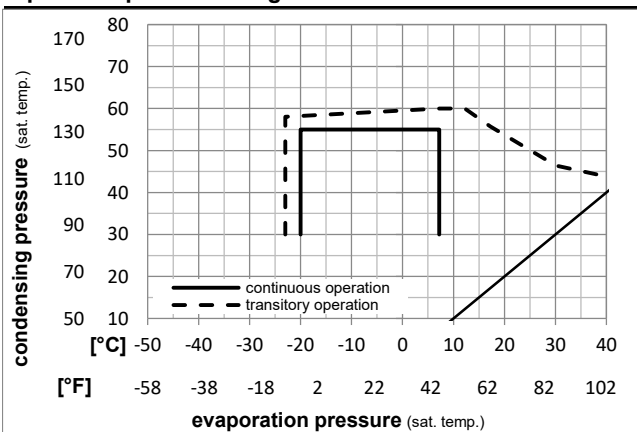

Components (cover, clamp, gasket: pre assembled)

a3	GS starter kit (600mm)	117-7056
b	cover	107B9101
b2	gasket	107B9100
b1	clamp	107B9104

Model

Designation **GS34MLX 220-240V/50Hz** Conf. 1 Sales code: **107B0504**

Optimization + standard conditions

R404A, 220V/50Hz, CSCR, fan 3m/s, VDE, CCC, EAC

		Evaporating pressure (saturation temperature)				Condensing pressure (saturation temperature)						Power consumption							
						Return gas temp.						Current consumption							
						Liquid temp.						Ref. mass flow							
						Cooling capacity						COP			EER	P1	I	m	
		pe	pc	RGT	Tliq	[W]	[Btu/h]	[kcal/h]	[W/W]	[Btu/Wh]	[kcal/Wh]	[W]	[A]	[kg/h]					
[°C]	-6,66	54,4	35	46,1	3363,0	11485	2894,3	1,71	5,85	1,47	1962,8	10,21	92,53	ASHRAE					
[°F]	20	130	95	115										MBP					
[°C]	-10	55	32	55	2521,0	8610	2169,6	1,36	4,66	1,17	1848,1	9,74	80,70	cecomaf					
[°F]	14	131	89,6	131										MBP					
[°C]	-10	45	20	45	2953,1	10085	2541,5	1,71	5,85	1,47	1725,3	9,28	88,95	EN12900					
[°F]	14	113	68	113										MBP					
[°C]	-6,66	48,9	18,3	48,9	3061,9	10457	2635,1	1,63	5,55	1,40	1883,4	9,92	100,05	ARI540					
[°F]	20	120	65	120										MBP					
[°C]	-10	45	32	45	3136,9	10713	2699,7	1,82	6,21	1,56	1725,3	9,28	86,38	opt					
[°F]	14	113	89,6	113															
[°C]	-25	45	32	45	1591,9	5437	1370,0	1,26	4,31	1,09	1260,4	7,64	42,94	opt					
[°F]	-13	113	89,6	113															

Performance tables

R404A, 220V/50Hz, CSCR, fan 3m/s, VDE, CCC, EAC

	pe	Cooling capacity			COP			EER			P1	I	m
	[°C]	[°F]	[W]	[Btu/h]	[kcal/h]	[W/W]	[Btu/Wh]	[kcal/Wh]	[W]	[A]	[kg/h]		
[°C / °F]	-20	-4	2041,7	6973	1757,1	1,44	4,92	1,24	1417,2	8,13	55,39		
cond. pressure	-15	5	2552,7	8718	2196,9	1,63	5,55	1,40	1570,8	8,68	69,73		
pc= 45/113	-10	14	3136,9	10713	2699,7	1,82	6,21	1,56	1725,3	9,28	86,38		
return gas temp.	-6,7	20	3568,6	12188	3071,2	1,95	6,66	1,68	1829,8	9,72	98,87		
RGT= 32/90	-5	23	3806,8	13001	3276,2	2,02	6,90	1,74	1884,8	9,95	105,83		
liquid temp	0	32	4575,6	15627	3937,8	2,23	7,61	1,92	2053,2	10,67	128,64		
Tliq= 45/113	7,2	45	5886,2	20102	5065,7	2,54	8,67	2,18	2319,5	11,82	168,79		
[°C / °F]	-20	-4	1618,9	5529	1393,3	1,09	3,74	0,94	1479,7	8,38	50,94		
cond. pressure	-15	5	2041,8	6973	1757,2	1,23	4,19	1,06	1665,1	9,03	64,75		
pc= 55/131	-10	14	2521,0	8610	2169,6	1,36	4,66	1,17	1848,1	9,74	80,70		
return gas temp	-6,7	20	2874,2	9816	2473,5	1,46	4,98	1,26	1969,6	10,24	92,66		
RGT= 32/90	-5	23	3069,0	10481	2641,2	1,51	5,16	1,30	2032,9	10,50	99,34		
liquid temp	0	32	3699,5	12634	3183,8	1,66	5,68	1,43	2223,4	11,33	121,32		
Tliq= 55/131	7,2	45	4782,4	16333	4115,7	1,90	6,49	1,64	2515,9	12,62	160,50		

Model

Designation	GS34MLX	220-240V/50Hz	Conf. 2	Sales code:	107B0504
-------------	----------------	----------------------	----------------	-------------	-----------------

Configuration

Motorconfiguration	CSCR
Power supply (nominal)	220-240V/50Hz 1~
Refrigerant	R452A
Application	MBP
Voltage range	198-254V
Starting torque	HST
Approvals	VDE
	CCC
	EAC

Electrical accessories / wiring diagram

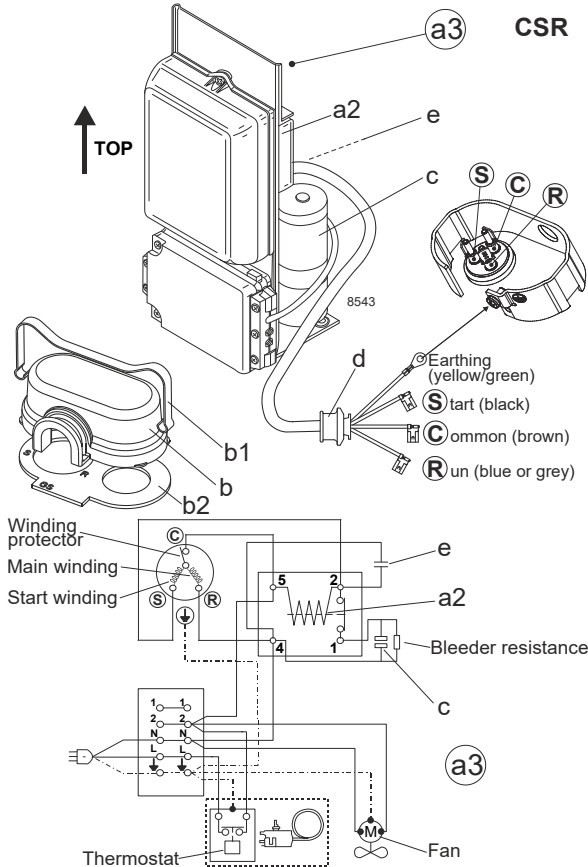

Ambient temperatures / system cooling

Ambient temperature min.:	10°C / 50°F
Ambient temperature max.:	43°C / 110°F

System cooling (n/a: outside limits)			
T ambient	LBP	MBP	HBP
32°C / 90°F	n/a	fan 3m/s	n/a
38°C / 100°F	n/a	fan 3m/s	n/a
43°C / 110°F	n/a	fan 3m/s	n/a

Operation pressure range

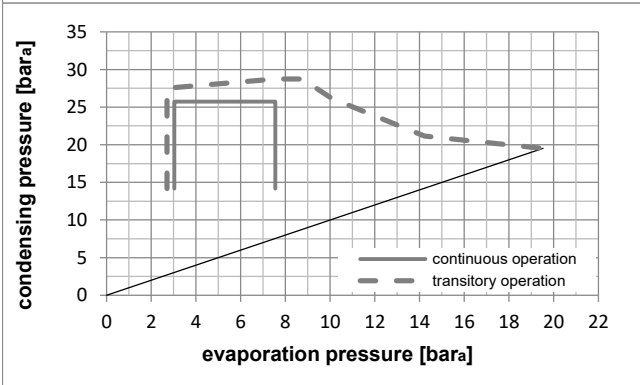
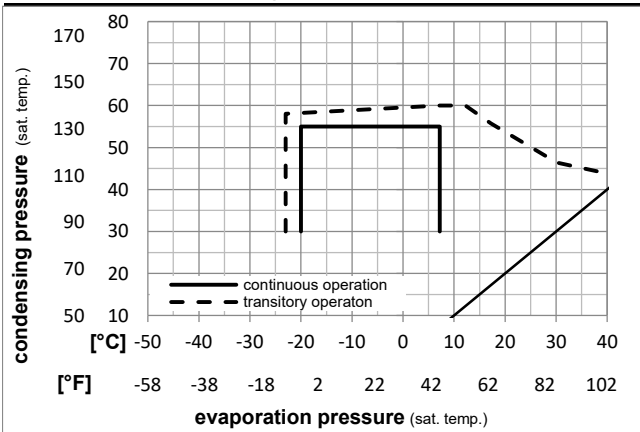

Components (cover, clamp, gasket: pre assembled)

a3	GS starter kit (600mm)	117-7056
b	cover	107B9101
b2	gasket	107B9100
b1	clamp	107B9104

Model

Designation **GS34MLX 220-240V/50Hz** Conf. 2 Sales code: **107B0504**

Optimization + standard conditions

R452A, 220V/50Hz, CSCR, fan 3m/s, VDE, CCC, EAC

Evaporating pressure (saturation temperature)		Condensing pressure (saturation temperature)				Cooling capacity						Power consumption			Ref. mass flow ṁ	
		Return gas temp.						COP		EER		P1	I			
		Liquid temp.				[W]	[Btu/h]	[kcal/h]	[W/W]	[Btu/Wh]	[kcal/Wh]	[W]	[A]	[kg/h]		
pe	pc	RGT	Tliq													
[°C]	-6,7	54,4	35	46,1	3424,6	11695	2947,2	1,85	6,31	1,59	1852,9	9,91	96,34	ASHRAE MBP		
[°F]	20	130	95	115												
[°C]	-10	55	32	55	2568,4	8771	2210,4	1,48	5,05	1,27	1737,7	9,47	83,48	cecomaf MBP		
[°F]	14	131	89,6	131												
[°C]	-10	45	20	45	2954,3	10089	2542,5	1,82	6,20	1,56	1626,7	9,05	90,77	EN12900 MBP		
[°F]	14	113	68	113												
[°C]	-6,7	48,9	18,3	48,9	3105,5	10606	2672,6	1,74	5,96	1,50	1780,4	9,63	103,02	ARI540 MBP		
[°F]	20	120	65	120												
[°C]	-10	45	32	45	3133,4	10701	2696,6	1,93	6,58	1,66	1626,7	9,05	88,29	opt		
[°F]	14	113	89,6	113												
[°C]	-25	45	32	45	1546,5	5282	1330,9	1,32	4,52	1,14	1169,0	7,31	42,78	opt		
[°F]	-13	113	89,6	113												

Performance tables

R452A, 220V/50Hz, CSCR, fan 3m/s, VDE, CCC, EAC

	pe		Cooling capacity			COP			EER		P1	I	m
	[°C]	[°F]	[W]	[Btu/h]	[kcal/h]	[W/W]	[Btu/Wh]	[kcal/Wh]	[W]	[A]	[kg/h]		
[°C / °F]	-20	-4	2003,6	6843	1724,4	1,51	5,17	1,30	1322,7	7,89	55,71		
cond. pressure	-15	5	2527,7	8633	2175,4	1,72	5,86	1,48	1473,9	8,47	70,71		
pc= 45/113	-10	14	3133,4	10701	2696,6	1,93	6,58	1,66	1626,7	9,05	88,29		
return gas temp.	-6,7	20	3585,3	12244	3085,5	2,07	7,07	1,78	1730,7	9,45	101,57		
RGT= 32/90	-5	23	3836,0	13101	3301,3	2,15	7,34	1,85	1785,7	9,65	109,00		
liquid temp	0	32	4651,8	15887	4003,4	2,38	8,13	2,05	1955,1	10,30	133,51		
Tliq= 45/113	7,2	45	6061,6	20701	5216,6	2,72	9,30	2,34	2226,1	11,33	177,08		
[°C / °F]	-20	-4	1614,7	5514	1389,6	1,17	4,01	1,01	1374,7	8,09	51,68		
cond. pressure	-15	5	2058,5	7030	1771,5	1,32	4,52	1,14	1556,5	8,78	66,35		
pc= 55/131	-10	14	2568,4	8771	2210,4	1,48	5,05	1,27	1737,7	9,47	83,48		
return gas temp	-6,7	20	2948,7	10070	2537,6	1,59	5,42	1,37	1859,0	9,93	96,44		
RGT= 32/90	-5	23	3160,0	10792	2719,5	1,64	5,61	1,41	1922,5	10,17	103,71		
liquid temp	0	32	3849,8	13148	3313,2	1,82	6,22	1,57	2115,4	10,91	127,83		
Tliq= 55/131	7,2	45	5052,7	17256	4348,4	2,09	7,14	1,80	2415,9	12,05	171,25		

Model

Designation	GS34MLX	220-240V/50Hz	Conf. 3	Sales code:	107B0504
-------------	----------------	----------------------	----------------	-------------	-----------------

Configuration

Motorconfiguration	CSCR
Power supply (nominal)	220-240V/50Hz 1~
Refrigerant	R448A
Application	MBP
Voltage range	198-254V
Starting torque	HST
Approvals	

Electrical accessories / wiring diagram

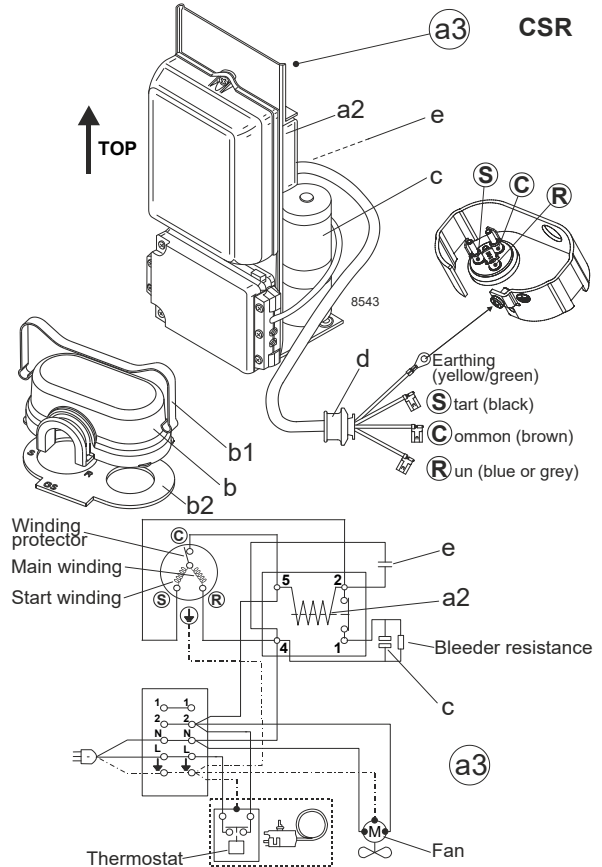

Ambient temperatures / system cooling

Ambient temperature min.:	10°C / 50°F
Ambient temperature max.:	38°C / 101°F

System cooling (n/a: outside limits)

T ambient	LBP	MBP	HBP
32°C / 90°F	n/a	fan 3m/s	n/a
38°C / 100°F	n/a	fan 3m/s	n/a
43°C / 110°F	n/a	n/a	n/a

Operation pressure range

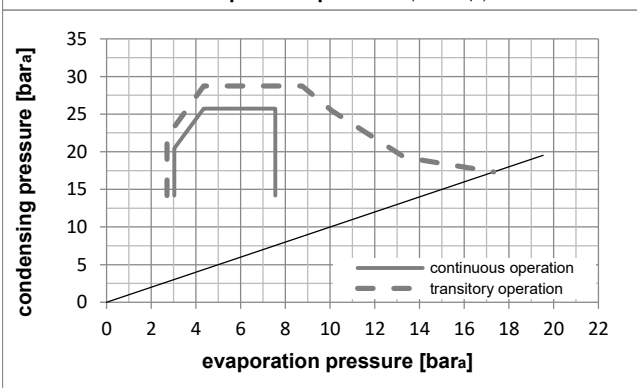
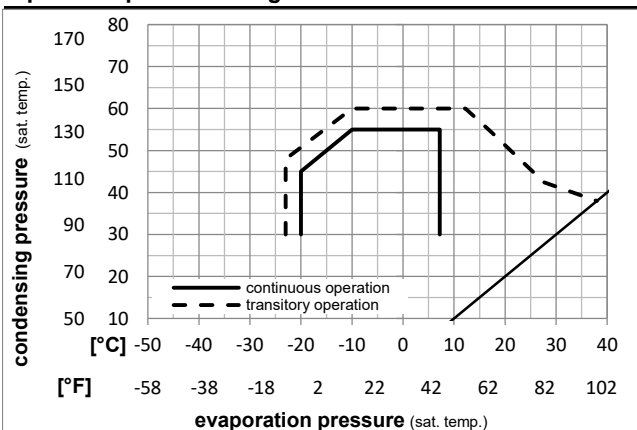

Components (cover, clamp, gasket: pre assembled)

a3	GS starter kit (600mm)	117-7056
b	cover	107B9101
b2	gasket	107B9100
b1	clamp	107B9104

Model

Designation **GS34MLX 220-240V/50Hz** Conf. 3 Sales code: **107B0504**

Optimization + standard conditions

R448A, 220V/50Hz, CSCR, fan 3m/s,

		Evaporating pressure (saturation temperature)				Condensing pressure (saturation temperature)				Power consumption							
		Return gas temp.				Liquid temp.				Cooling capacity		COP	EER	P1	I	Ref. mass flow	
		pe	pc	RGT	Tliq	[W]	[Btu/h]	[kcal/h]	[W/W]	[Btu/Wh]	[kcal/Wh]	[W]	[A]	[kg/h]			
[°C]	-6,66	54,4	35	46,1	3217,4	10988	2768,9	1,83	6,24	1,57	1760,2	9,56	70,28	ASHRAE			
[°F]	20	130	95	115										MBP			
[°C]	-10	55	32	55	2473,2	8446	2128,4	1,50	5,13	1,29	1646,0	9,12	60,57	cecomaf			
[°F]	14	131	89,6	131										MBP			
[°C]	-10	45	20	45	2832,1	9672	2437,3	1,84	6,28	1,58	1539,8	8,72	66,25	EN12900			
[°F]	14	113	68	113										MBP			
[°C]	-6,66	48,9	18,3	48,9	3030,2	10349	2607,9	1,79	6,12	1,54	1690,3	9,29	75,36	ARI540			
[°F]	20	120	65	120										MBP			
[°C]	-10	45	32	45	2949,7	10074	2538,5	1,92	6,54	1,65	1539,8	8,72	64,45	opt			
[°F]	14	113	89,6	113													
[°C]	-25	45	32	45	1415,2	4833	1217,9	1,30	4,43	1,12	1090,2	7,01	30,43	opt			
[°F]	-13	113	89,6	113													

Performance tables

R448A, 220V/50Hz, CSCR, fan 3m/s,

	pe		Cooling capacity			COP			EER			P1	I	m
	[°C]	[°F]	[W]	[Btu/h]	[kcal/h]	[W/W]	[Btu/Wh]	[kcal/Wh]	[W]	[A]	[kg/h]			
[°C / °F]	-20	-4	1853,1	6329	1594,8	1,49	5,10	1,29	1240,9	7,58	40,03			
cond. pressure	-15	5	2359,5	8058	2030,6	1,70	5,80	1,46	1389,4	8,15	51,24			
pc= 45/113	-10	14	2949,7	10074	2538,5	1,92	6,54	1,65	1539,8	8,72	64,45			
return gas temp.	-6,7	20	3392,6	11586	2919,7	2,07	7,06	1,78	1642,1	9,11	74,48			
RGT= 32/90	-5	23	3639,1	12428	3131,9	2,15	7,33	1,85	1696,3	9,31	80,11			
liquid temp	0	32	4444,3	15178	3824,8	2,39	8,15	2,05	1863,0	9,95	98,70			
Tliq= 45/113	7,2	45	5842,9	19954	5028,4	2,74	9,37	2,36	2129,5	10,96	131,79			
[°C / °F]	-20	-4	1524,4	5206	1311,9	1,18	4,04	1,02	1289,1	7,77	36,86			
cond. pressure	-15	5	1963,6	6706	1689,9	1,34	4,57	1,15	1467,4	8,44	47,75			
pc= 55/131	-10	14	2473,2	8446	2128,4	1,50	5,13	1,29	1646,0	9,12	60,57			
return gas temp	-6,7	20	2855,7	9753	2457,6	1,62	5,52	1,39	1766,0	9,58	70,31			
RGT= 32/90	-5	23	3068,9	10481	2641,2	1,68	5,73	1,44	1828,9	9,82	75,79			
liquid temp	0	32	3767,5	12867	3242,3	1,86	6,37	1,60	2020,4	10,55	93,96			
Tliq= 55/131	7,2	45	4990,2	17042	4294,6	2,15	7,35	1,85	2319,6	11,68	126,65			

Model

Designation	GS34MLX	220-240V/50Hz	Conf. 4	Sales code:	107B0504
-------------	----------------	----------------------	----------------	-------------	-----------------

Configuration

Motorconfiguration	CSCR
Power supply (nominal)	220-240V/50Hz 1~
Refrigerant	R449A
Application	MBP
Voltage range	198-254V
Starting torque	HST
Approvals	

Electrical accessories / wiring diagram

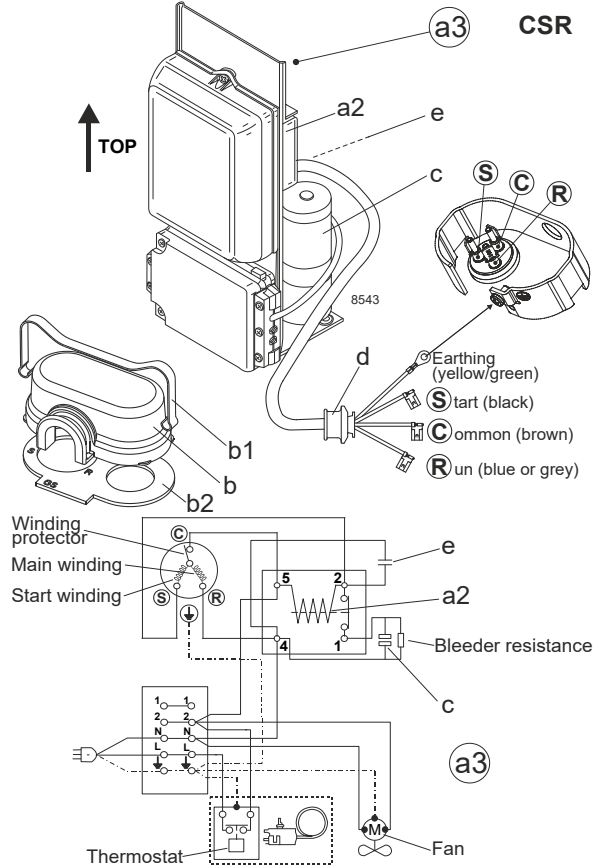

Ambient temperatures / system cooling

Ambient temperature min.:	10°C / 50°F
Ambient temperature max.:	38°C / 101°F

System cooling (n/a: outside limits)			
T ambient	LBP	MBP	HBP
32°C / 90°F	n/a	fan 3m/s	n/a
38°C / 100°F	n/a	fan 3m/s	n/a
43°C / 110°F	n/a	n/a	n/a

Operation pressure range

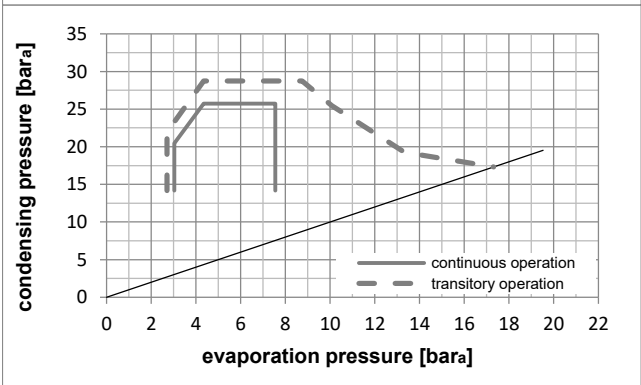
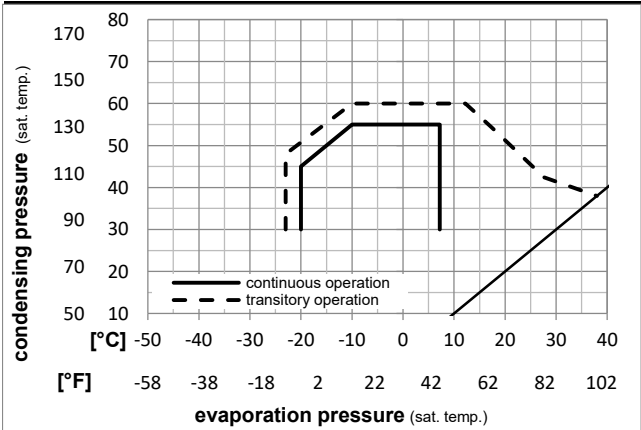

Components (cover, clamp, gasket: pre assembled)

a3	GS starter kit (600mm)	117-7056
b	cover	107B9101
b2	gasket	107B9100
b1	clamp	107B9104

Model

Designation **GS34MLX 220-240V/50Hz** Conf. 4 Sales code: **107B0504**

Optimization + standard conditions

R449A, 220V/50Hz, CSCR, fan 3m/s,

Evaporating pressure (saturation temperature)		Condensing pressure (saturation temperature)				Return gas temp.		Liquid temp.		Cooling capacity			COP		EER		Power consumption		Current consumption		Ref. mass flow	
pe	pc	RGT	Tliq		[W]	[Btu/h]	[kcal/h]	[W/W]	[Btu/Wh]	[kcal/Wh]	P1	I										
[°C]	[°C]	[°C]	[°C]	[°C]							[W]	[A]	[kg/h]									
-6,66	54,4	35	46,1		3205,3	10947	2758,5	1,83	6,26	1,58	1749,7	9,52	71,40									ASHRAE MBP
20	130	95	115																			
-10	55	32	55		2460,8	8404	2117,8	1,50	5,13	1,29	1637,1	9,09	61,55									cecomaf MBP
14	131	89,6	131																			
-10	45	20	45		2817,1	9621	2424,4	1,84	6,28	1,58	1532,5	8,69	67,28									EN12900 MBP
14	113	68	113																			
-6,66	48,9	18,3	48,9		3012,0	10286	2592,1	1,79	6,12	1,54	1681,0	9,26	76,55									ARI540 MBP
20	120	65	120																			
-10	45	32	45		2937,2	10031	2527,8	1,92	6,55	1,65	1532,5	8,69	65,45									opt
14	113	89,6	113																			
-25	45	32	45		1411,4	4820	1214,7	1,30	4,43	1,12	1086,9	7,00	30,95									opt
-13	113	89,6	113																			

Performance tables

R449A, 220V/50Hz, CSCR, fan 3m/s,

[°C / °F]	pe	Cooling capacity			COP		EER		P1	I	m
	[°C]	[°F]	[W]	[Btu/h]	[kcal/h]	[W/W]	[Btu/Wh]	[kcal/Wh]	[W]	[A]	[kg/h]
-20	-4	1847,0	6308	1589,5	1,49	5,10	1,29	1236,4	7,57	40,68	
cond. pressure	-15	5	2350,5	8027	2022,9	1,70	5,80	1,46	1383,6	8,13	52,05
pc= 45/113	-10	14	2937,2	10031	2527,8	1,92	6,55	1,65	1532,5	8,69	65,45
return gas temp.	-6,7	20	3377,6	11535	2906,8	2,07	7,06	1,78	1633,7	9,08	75,63
RGT= 32/90	-5	23	3622,7	12372	3117,7	2,15	7,33	1,85	1687,2	9,28	81,34
liquid temp	0	32	4423,2	15106	3806,6	2,39	8,16	2,06	1851,6	9,90	100,20
Tliq= 45/113	7,2	45	5813,5	19854	5003,1	2,75	9,39	2,37	2113,6	10,90	133,78
-20	-4	1518,2	5185	1306,6	1,18	4,04	1,02	1284,2	7,75	37,48	
cond. pressure	-15	5	1954,6	6675	1682,1	1,34	4,57	1,15	1460,7	8,42	48,54
pc= 55/131	-10	14	2460,8	8404	2117,8	1,50	5,13	1,29	1637,1	9,09	61,55
return gas temp	-6,7	20	2840,9	9702	2444,9	1,62	5,53	1,39	1755,4	9,54	71,44
RGT= 32/90	-5	23	3052,7	10426	2627,2	1,68	5,74	1,45	1817,4	9,77	77,00
liquid temp	0	32	3746,8	12796	3224,6	1,87	6,38	1,61	2005,6	10,49	95,45
Tliq= 55/131	7,2	45	4961,8	16946	4270,2	2,16	7,37	1,86	2298,8	11,60	128,66

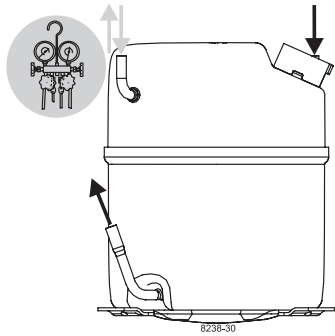

GS Compressors

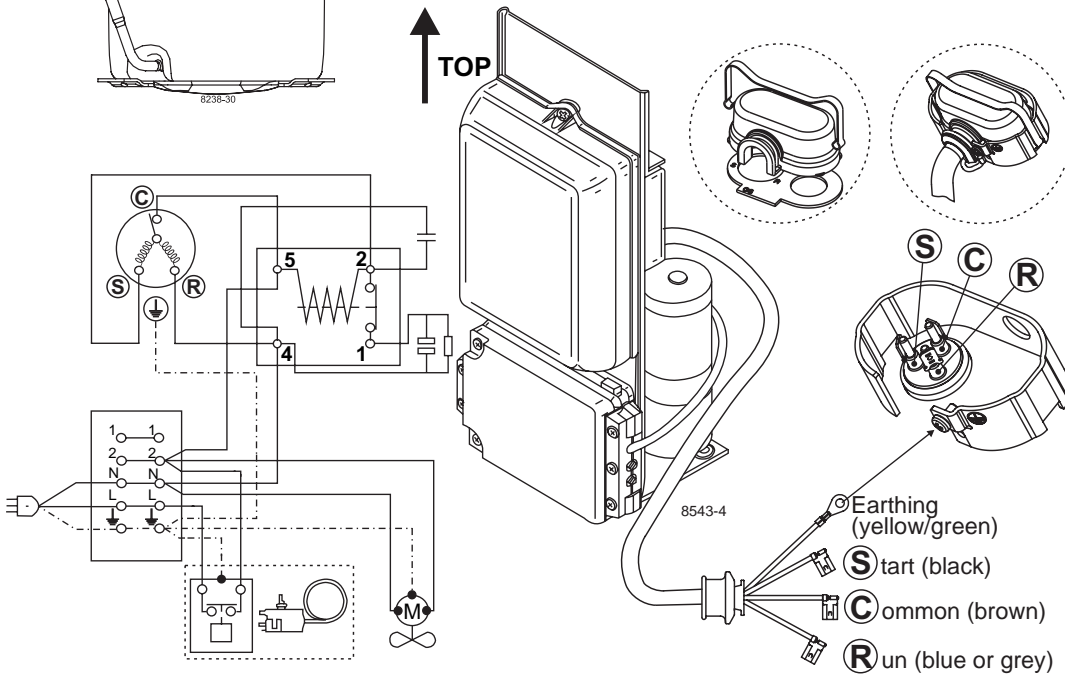

	S	C	R
ENGLISH	Black	Brown	Blue or grey
DEUTSCH	Schwarz	Braun	Blau od. grau
FRANÇAIS	Noir	Marron	Bleu ou gris
ESPAÑOL	Negro	Marrón	Azul o gris
ITALIANO	Nero	Marrone	Blu o grigio
NEDERLANDS	Zwart	Bruin	Blauw of grijs
DANSK	Sort	Brun	Blå eller grå
SVENSKA	Svart	Brun	Blå eller grå
SUOMEKSI	Musta	Ruskea	Sininen tai harmaa
РУССКИЙ	Чёрный	Коричневый	Синий или серый
中文	黑色	棕色	蓝色或灰色

Secop accepts no responsibility for possible errors in catalogs, brochures, and other printed material. Secop reserves the right to alter its products without notice. This also applies to products already on order provided that such alterations can be made without consequential changes being necessary to specifications already agreed. All trademarks in this material are the property of the respective companies. Secop and the Secop logotype are trademarks of Secop GmbH. All rights reserved. www.secop.com