

Single Pack BD50K 12/24V DC PM

Codice Imballo Singolo: **195B4644**

Posizione	Titolo	Codice	Quantità
1	Compressor BD50K	101Z0213	1
2	Electronic unit High Speed	101N0390	1
3	Bolt joint for one compressor M6 ø16mm	118-1917	1

Secop GmbH • Lise-Meitner-Straße 29 • 24941 Flensburg, Germany • Tel: +49 46149410 • www.secop.com

Secop non si assume alcuna responsabilità per eventuali errori presenti in cataloghi, brochure e altro materiale stampato. Secop si riserva il diritto di modificare i propri prodotti senza preavviso. Ciò vale anche per i prodotti già ordinati, a condizione che tali modifiche possano essere apportate senza che siano necessarie modifiche successive alle specifiche già concordate. Tutti i marchi presenti in questo materiale sono di proprietà delle rispettive aziende. Secop e il logo Secop sono marchi di Secop GmbH. Tutti i diritti sono riservati.

BD50K Direct Current Compressor R600a 12/24V DC



General

Code number (without electronic units)	101Z0213
Electronic unit 12/24V DC - High Speed	101N0390, 30 pcs: 101N0391
Compressors on pallet	150

Application

Application	LBP/MBP/HBP	
Evaporating temperature	°C	-30 to 10
Voltage range DC	VDC	9.6 - 17 / 21.3 - 31.5
Max. condensing temperature continuous (short)	°C	60 (70)
Max. winding temperature continuous (short)	°C	125 (135)

Cooling requirements

Application	LBP	MBP	HBP
32°C	S	S	S
38°C	S	S	S
43°C	S	S	S
Remarks on application:			

Motor

Motor type	variable speed	
Resistance, all 3 windings (25°C)	Ω	1.8

Design

Displacement	cm ³	3.00
Oil quantity (type)	cm ³	150 (polyolester)
Maximum refrigerant charge	g	120
Free gas volume in compressor	cm ³	870
Weight - Compressor/Electronic unit	kg	4.4 / 0.32

Standard battery protection settings (refer to electronic unit *Instructions* for optional settings)

Voltage		12V	24V
Cut out	VDC	10.4	22.8
Cut in	VDC	11.7	24.2

Dimensions

Height	mm	A	137
		B	135
		B1	128
		B2	73
Suction connector	location/I.D. mm angle	C	6.2 40°
	material comment	Cu-plated steel Al cap	
Process connector	location/I.D. mm angle	D	6.2 45°
	material comment	Cu-plated steel Al cap	
Discharge connector	location/I.D. mm angle	E	5.0 21°
	material comment	Cu-plated steel Al cap	
Connector tolerance	I.D. mm	±0.09, on 5.0 +0.12/+0.20	
Remarks:			

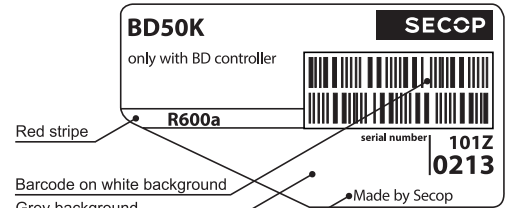

Red stripe
Barcode on white background
Grey background
Country of origin or manufacturer
Made by Secop



- S = Static cooling normally sufficient
- O = Oil cooling
- F₁ = Fan cooling 1.5 m/s
(compressor compartment temperature equal to ambient temperature)
- F₂ = Fan cooling 3.0 m/s necessary
- SG = Suction gas cooling normally sufficient
- = not applicable in this area

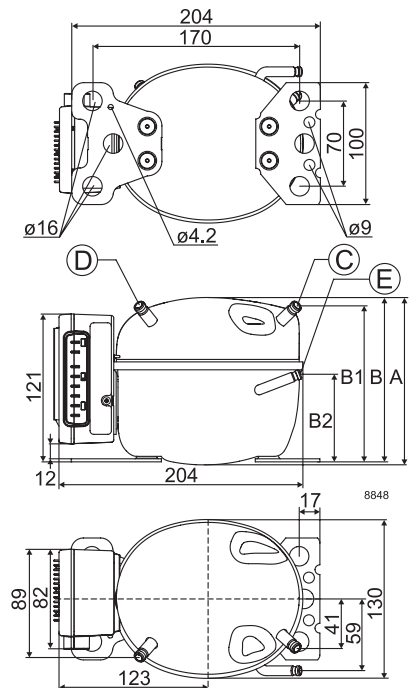

Capacity (EN 12900 Household/CECOMAF) 24V DC, static cooling watt												
rpm \ °C	-30	-25	-23.3	-20	-15	-10	-5	0	5	7.2	10	15
2,500	16.9	23.8	26.6	32.7	43.8	57.2	73.1	91.7	113	123	137	
3,100	21.3	29.9	33.4	41.1	55.0	71.9	91.9	115	142	155	173	
3,800	25.9	36.4	40.7	50.1	67.0	87.6	112	140	173	189	210	
4,400	29.9	42.0	46.9	57.7	77.3	101	129	162	199	218	242	

Capacity (ASHRAE LBP) 24V DC, static cooling watt												
rpm \ °C	-30	-25	-23.3	-20	-15	-10	-5	0	5	7.2	10	15
2,500	20.6	29.0	32.4	39.9	53.4	69.8	89.3	112	138	151	168	
3,100	25.9	36.4	40.7	50.1	67.1	87.7	112	141	174	189	211	
3,800	31.5	44.4	49.6	61.1	81.8	107	137	171	211	231	257	
4,400	36.4	51.2	57.2	70.4	94.3	123	158	198	244	266	296	

Power consumption 24V DC, static cooling watt												
rpm \ °C	-30	-25	-23.3	-20	-15	-10	-5	0	5	7.2	10	15
2,500	24.9	26.8	27.6	29.3	32.4	35.8	39.6	43.6	47.6	49.4	51.7	
3,100	32.4	35.5	36.8	39.6	44.4	49.8	55.6	61.6	67.6	70.2	73.5	
3,800	37.4	43.1	45.2	49.5	56.6	64.1	71.9	79.6	87.3	90.5	94.6	
4,400	41.6	50.0	53.0	58.8	67.7	76.7	85.7	94.4	103	107	111	

Current consumption (for 12V applications the following must be doubled) A												
rpm \ °C	-30	-25	-23.3	-20	-15	-10	-5	0	5	7.2	10	15
2,500	0.6	0.8	0.8	1.0	1.2	1.4	1.7	1.9	2.2	2.2	2.4	
3,100	0.8	1.0	1.1	1.3	1.6	1.9	2.3	2.7	3.0	3.1	3.3	
3,800	1.1	1.4	1.5	1.7	2.1	2.5	2.9	3.3	3.7	3.8	4.0	
4,400	1.6	1.9	2.0	2.3	2.6	3.0	3.4	3.8	4.1	4.2	4.4	

COP (EN 12900 Household/CECOMAF) 24V DC, static cooling W/W												
rpm \ °C	-30	-25	-23.3	-20	-15	-10	-5	0	5	7.2	10	15
2,500	0.68	0.89	0.96	1.11	1.35	1.60	1.85	2.10	2.37	2.50	2.66	
3,100	0.66	0.84	0.91	1.04	1.24	1.44	1.65	1.87	2.10	2.21	2.35	
3,800	0.69	0.85	0.90	1.01	1.18	1.37	1.56	1.76	1.98	2.09	2.22	
4,400	0.72	0.84	0.89	0.98	1.14	1.32	1.51	1.71	1.94	2.04	2.18	

COP (ASHRAE LBP) 24V DC, static cooling W/W												
rpm \ °C	-30	-25	-23.3	-20	-15	-10	-5	0	5	7.2	10	15
2,500	0.83	1.08	1.17	1.36	1.65	1.95	2.26	2.58	2.91	3.07	3.27	
3,100	0.80	1.02	1.10	1.26	1.51	1.76	2.02	2.29	2.58	2.71	2.89	
3,800	0.84	1.03	1.10	1.23	1.45	1.67	1.91	2.16	2.43	2.56	2.73	
4,400	0.87	1.02	1.08	1.20	1.39	1.61	1.84	2.10	2.38	2.51	2.68	

Test conditions	EN 12900/CECOMAF	ASHRAE LBP
Condensing temperature	55°C	54.4°C
Ambient temperature	32°C	32°C
Suction gas temperature	32°C	32°C
Liquid temperature	no subcooling	32°C

Accessories for BD50K	Code number
Bolt joint for one comp.	Ø:16 mm 118-1917
Bolt joint in quantities	Ø:16 mm 118-1918
Snap-on in quantities	Ø:16 mm 118-1919
Remote kit (without cable)	105N9210
Secop Gateway	105N9518
Automobile fuse, DIN 7258	12V: 30A 24V: 15 A
Main switch	min. 30A Not deliverable from Secop

Compressor speed	Resistor (R1) [Ω]	Motor speed
Code number	calculated values	[rpm]
101N0390 with AEO	0	AEO
	203	2,500
	451	3,100
	867	3,800
	1700	4,400

In AEO (Adaptive Energy Optimizing) speed mode the BD compressor will always adapt its speed to the actual cooling demand.

Size		Max. length* 12V operation		Max. length* 24V operation	
Cross section	AWG	[m]	[ft.]	[m]	[ft.]
[mm²]	[Gauge]				
6	10	2.5	8	5	16

*Length between battery and electronic unit

Operational errors	Error type
	Can be read out in the software TOOL4COOL®
6	Thermostat failure (If the NTC thermistor is short-circuit or has no connection).
5	Thermal cut-out of electronic unit (If the refrigeration system has been too heavily loaded, or if the ambient temperature is high, the electronic unit will run too hot).
4	Minimum motor speed error (If the refrigeration system is too heavily loaded, the motor cannot maintain minimum speed at approximately 1,850 rpm).
3	Motor start error (The rotor is blocked or the differential pressure in the refrigeration system is too high (>5 bar)).
2	Too many start attempts or fan over current (Too many compressor or fan starts in short time or fan current higher than 0.5A _{avg}).
1	Battery protection cut-out (The voltage is outside the cut-out setting).

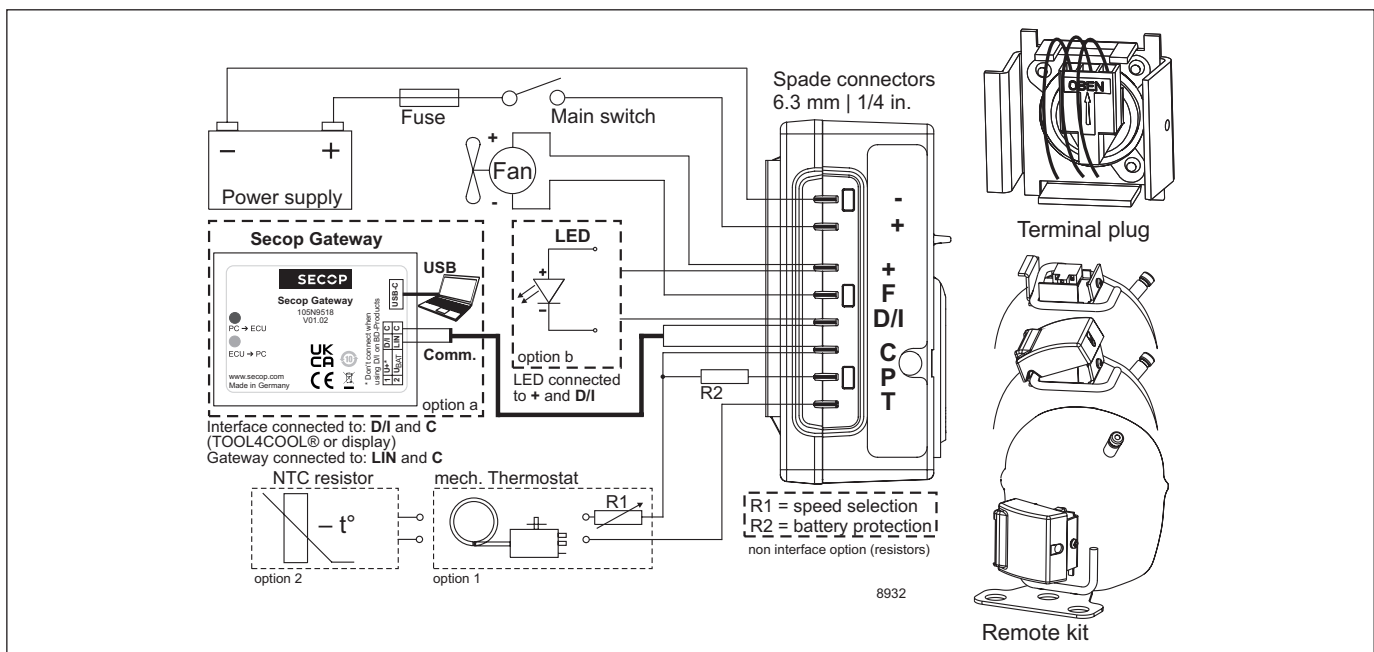

Secop accepts no responsibility for possible errors in catalogs, brochures, and other printed material. Secop reserves the right to alter its products without notice. This also applies to products already on order provided that such alterations can be made without consequential changes being necessary to specifications already agreed. All trademarks in this material are the property of the respective companies. Secop and the Secop logotype are trademarks of Secop GmbH. All rights reserved. www.secop.com



Instructions for Electronic Units
are available for download on
www.secop.com



BD Compressors



Service/Repair

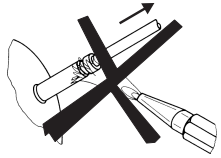

BD Nano



**! max. 150°C/302°F !
at socket**
brazing solder: silver with flux

Do not heat up the bottom of the discharge connector directly.
Do not braze longer than 10 seconds and wait for 5 minutes for the next soldering attempt (Product Bulletin DES.N.101.M1).

BD Micro

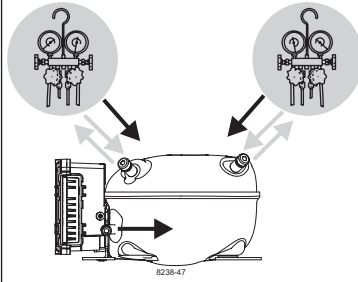

BD P-Housing

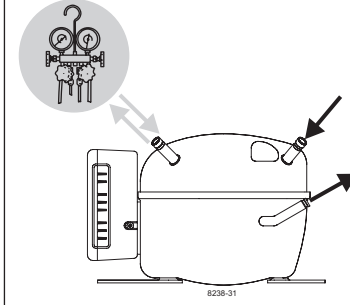

BD T-Housing

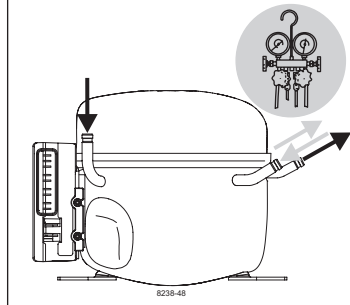

Secop accepts no responsibility for possible errors in catalogs, brochures, and other printed material. Secop reserves the right to alter its products without notice. This also applies to products already on order provided that such alterations can be made without subsequential changes being necessary to specifications already agreed. All trademarks in this material are the property of the respective companies. Secop and the Secop logotype are trademarks of Secop GmbH. All rights reserved. www.secop.com