

Single Pack SC15CLX.2 115V 60Hz CSCR

Codice Imballo Singolo: **195B4670**

Posizione	Titolo	Codice	Quantità
1	Compressor SC15CLX.2	104L1853	1
2	SC starting device (600mm)	117-7045	1
3	Bolt joint for one compressor M6 ø16mm	118-1917	1

Secop GmbH • Lise-Meitner-Straße 29 • 24941 Flensburg, Germany • Tel: +49 46149410 • www.secop.com

Secop non si assume alcuna responsabilità per eventuali errori presenti in cataloghi, brochure e altro materiale stampato. Secop si riserva il diritto di modificare i propri prodotti senza preavviso. Ciò vale anche per i prodotti già ordinati, a condizione che tali modifiche possano essere apportate senza che siano necessarie modifiche successive alle specifiche già concordate. Tutti i marchi presenti in questo materiale sono di proprietà delle rispettive aziende. Secop e il logo Secop sono marchi di Secop GmbH. Tutti i diritti sono riservati.

Model

Designation	SC15CLX.2	115V/60Hz 1~	Sales code:	104L1853
-------------	------------------	--------------	-------------	-----------------

Compressor design

Oil type	Polyolester	Refrigerant(s)	R404A, R452A, R507
Oil viscosity	32cST	Displacement	15,28cm ³ / 0,93cu.in
Oil quantity	500cm ³ / 16,9fl.oz	Compressors on pallet	80
Refr. charge - tech. limit	1300g / 45,9oz		
Free gas volume comp.	1460cm ³ / 49,4fl.oz		
Weight	13,7kg / 30,2lbs		
Motor protection	external		
Winding resistance main	0,66Ω (at 25°C)		
Winding resistance aux	2,7Ω (at 25°C)		
Max. winding temp.	125°C / 257°F		
Max. discharge temp.	130°C / 266°F		



General - Configurations with SC15CLX.2

	Conf. 1	Conf. 2	Conf. 3	Conf. 4
Motorconfiguration	CSIR	CSCR	CSIR	CSCR
Power supply (nominal)	115V/60Hz	115V/60Hz	115V/60Hz	115V/60Hz
Number of phases	1	1	1	1
Voltage range	103-127V	103-127V	103-127V	103-127V
Approvals	UL	UL	UL	UL
Starting torque	HST	HST	HST	HST
Note	Protector and cover are included and pre-assembled to compressor.			

Applications with SC15CLX.2

	Conf. 1	Conf. 2	Conf. 3	Conf. 4
Refrigerant	R404A	R404A	R452A	R452A
Application	LBP	LBP	LBP	LBP
System cooling	fan 3m/s	fan 3m/s	fan 3m/s	fan 3m/s
Hot gas defrost	OK	OK	OK	OK
Long interval pull down	-/-	-/-	-/-	-/-

Electrical data - Configurations with SC15CLX.2

	Conf. 1	Conf. 2	Conf. 3	Conf. 4
Starting device type	relay	relay	relay	relay
Run capacitor	-/-	23,5μF	-/-	23,5μF
Start capacitor	410μF	410μF	410μF	410μF
LRA (locked rotor amps / 4s)	56,8A	54,2A	56,8A	54,2A
RLA (rated load amps / 1s)	9,8A	8,8A	9,8A	8,8A
Cut in current	56,8A	54,2A	56,8A	54,2A
IP class	21	21	21	21

Model

Designation	SC15CLX.2	115V/60Hz 1~	Sales code:	104L1853
-------------	------------------	--------------	-------------	-----------------

Compressor dimensions

Housing	A Height	219mm / 8,62in
	B Height	213mm / 8,39in
	C Length shell	218mm / 8,58in
	D Length w. cover	255mm / 10,04in
	E Width	151mm / 5,94in

Connectors		Suction	Discharge	Process
		X	Y	Z
Diameter	[mm]	øi 9,54-9,72	øi 6,41-6,59	øi 6,41-6,59
(i:inside, o:outside)	[in]	øi 0,38-0,38	øi 0,25-0,26	øi 0,25-0,26
Material		copper	copper	copper
Horizontal angle	±2°	37°	37°	143°
Vertical angle	±2°	30°	0°	150°
Position l/h/w	[mm]	107/193/55	115/110/63	-107/193/55
	[in]	4,2/7,6/2,2	4,5/4,3/2,5	-4,2/7,6/2,2
Straight tube l.	[mm]	12	12	12
	[in]	0,5	0,5	0,5



Compressor fixation



Baseplate	[mm]	[inch]
BI	204	8.03
BW	150	5.9
øE	ø 9.7	ø 0.38
Large holes	[mm]	[inch]
LI	165	6.5
LW	101.6	4
øL	ø 19	ø 0.75
Small holes	[mm]	[inch]
SI	170	6.7
SW	70	2.76
øS	ø 16	ø 0.63
QI	127	5
Qw	127	5

Bolt joint

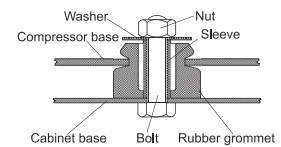

Snap-on



Mounting accessories

	one comp.	multi pack
Bolt joint M6 ø16mm	118-1917	118-1918
Bolt joint ø1/4" ø16mm	118-1946	
Bolt joint ø1/4" ø19mm	118-1949	
Snap-on ø7,3 ø16mm	118-1947	118-1919

Application notes

LRA value on compressor label and datasheet may differ due to different test conditions for UL approval.

Model

Designation **SC15CLX.2 115V/60Hz** Conf. 1 Sales code: **104L1853**

Configuration

Motorconfiguration CSIR
 Power supply (nominal) 115V/60Hz 1~
 Refrigerant R404A
 Application LBP
 Voltage range 103-127V
 Starting torque HST
 Approvals UL

Electrical accessories / wiring diagram

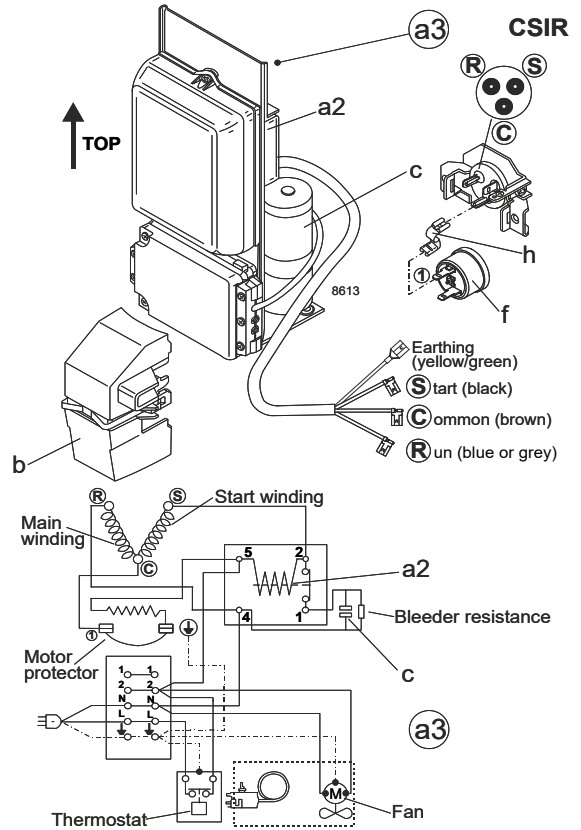

Ambient temperatures / system cooling

Ambient temperature min.: 10°C / 50°F
 Ambient temperature max.: 43°C / 110°F

System cooling (n/a: outside limits)			
T ambient	LBP	MBP	HBP
32°C / 90°F	fan 3m/s	n/a	n/a
38°C / 100°F	fan 3m/s	n/a	n/a
43°C / 110°F	fan 3m/s	n/a	n/a

Operation pressure range

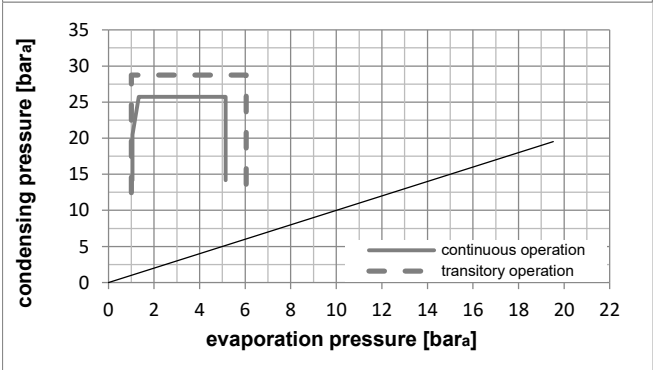
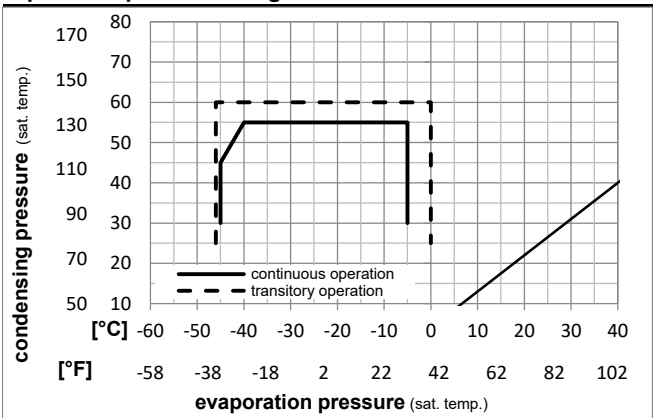

Components (protector + ~holder + cover: pre assembled)

- a3 SC starter kit 117-7053
- f ext. protector (T0761/46) 117U3212
- h protector holder 117U0439
- b plastic cover 117U1021

Alternative comp. (protector + ~holder + cover: pre assemb.)

- a2 potential relay (RVA 7AA3R) 117-7441
- c start capacitor 117U5042
- f ext. protector (T0761/46) 117U3212
- h protector holder 117U0439
- b plastic cover 117U1021

Model

Designation **SC15CLX.2 115V/60Hz** Conf. 1 Sales code: **104L1853**

Optimization + standard conditions

115V/60Hz, CSIR, fan 3m/s, UL

Evaporating pressure (saturation temperature)														
Condensing pressure (saturation temperature)														
Return gas temp.														
Liquid temp.														
Cooling capacity														
COP														
EER														
Power consumption														
Current consumption														
Ref. mass flow														
	pe	pc	RGT	Tliq	[W]	[Btu/h]	[kcal/h]	[W/W]	[Btu/Wh]	[kcal/Wh]	P1	I	m	
[°C]	[°C]	[°C]	[°C]	[°C]							[W]	[A]	[kg/h]	
[°F]	-23,3	54,4	32,2	32,2	880,0	3005	757,4	1,21	4,12	1,04	729,0	9,23	20,51	ASHRAE LBP
[°F]	-10	130	90	90										
[°C]	-25	55	32	55	592,4	2023	509,8	0,85	2,89	0,73	699,9	9,05	18,51	cecomaf LBP
[°F]	-13	131	89,6	131										
[°C]	-35	40	20	40	478,1	1633	411,4	0,93	3,18	0,80	512,7	7,99	12,99	EN12900 LBP
[°F]	-31	104	68	104										
[°C]	-23,3	48,9	4,44	48,9	664,9	2271	572,2	0,93	3,19	0,80	711,1	9,17	23,54	ARI540 LBP
[°F]	-10	120	40	120										
[°C]	-23,3	40,6	32,2	32,2	1017,4	3475	875,6	1,48	5,06	1,28	686,5	9,04	23,71	AHAM LBP
[°F]	-10	105	90	90										
[°C]	-35	45	32	45	436,6	1491	375,8	0,85	2,89	0,73	515,4	7,99	11,67	opt
[°F]	-31	113	89,6	113										

Performance tables

115V/60Hz, CSIR, fan 3m/s, UL

	pe		Cooling capacity			COP		EER		P1	I	m
	[°C]	[°F]	[W]	[Btu/h]	[kcal/h]	[W/W]	[Btu/Wh]	[kcal/Wh]	[W]	[A]	[kg/h]	
[°C / °F]	-45	-49	193,6	661	166,6	0,54	1,85	0,47	358,1	7,09	5,14	
cond. pressure	-34,4	-30	452,7	1546	389,6	0,86	2,95	0,74	524,0	8,04	12,11	
pc= 45/113	-28,9	-20	631,1	2155	543,1	1,03	3,53	0,89	610,6	8,57	16,96	
return gas temp.	-23,3	-10	844,2	2883	726,5	1,21	4,12	1,04	699,2	9,12	22,81	
RGT= 32/90	-20,6	-5	965,3	3297	830,7	1,30	4,43	1,12	744,9	9,40	26,17	
liquid temp	-15	5	1239,2	4232	1066,5	1,47	5,04	1,27	840,4	9,98	33,85	
Tliq= 45/113	-5	23	1851,8	6324	1593,7	1,80	6,13	1,55	1031,5	11,07	51,48	
[°C / °F]	-45	-49	92,8	317	79,8	0,28	0,97	0,25	325,6	6,90	2,85	
cond. pressure	-34,4	-30	317,1	1083	272,9	0,60	2,06	0,52	526,2	8,00	9,81	
pc= 55/131	-28,9	-20	469,0	1602	403,6	0,75	2,55	0,64	628,3	8,61	14,59	
return gas temp	-23,3	-10	650,0	2220	559,4	0,89	3,04	0,77	730,8	9,24	20,36	
RGT= 32/90	-20,6	-5	752,9	2571	648,0	0,96	3,29	0,83	782,8	9,56	23,67	
liquid temp	-15	5	986,3	3369	848,9	1,11	3,79	0,95	889,4	10,22	31,28	
Tliq= 55/131	-5	23	1511,8	5163	1301,1	1,38	4,71	1,19	1096,2	11,46	48,93	

Model

Designation	SC15CLX.2	115V/60Hz	Conf. 2	Sales code:	104L1853
-------------	------------------	------------------	----------------	-------------	-----------------

Configuration

Motorconfiguration	CSCR
Power supply (nominal)	115V/60Hz 1~
Refrigerant	R404A
Application	LBP
Voltage range	103-127V
Starting torque	HST
Approvals	UL

Electrical accessories / wiring diagram

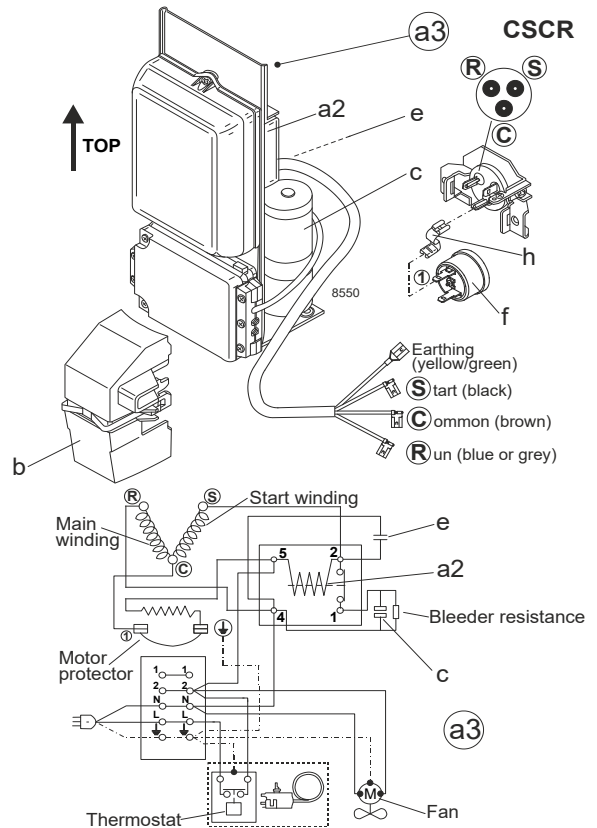

Ambient temperatures / system cooling

Ambient temperature min.:	10°C / 50°F
Ambient temperature max.:	43°C / 110°F

System cooling (n/a: outside limits)			
T ambient	LBP	MBP	HBP
32°C / 90°F	fan 3m/s	n/a	n/a
38°C / 100°F	fan 3m/s	n/a	n/a
43°C / 110°F	fan 3m/s	n/a	n/a

Operation pressure range

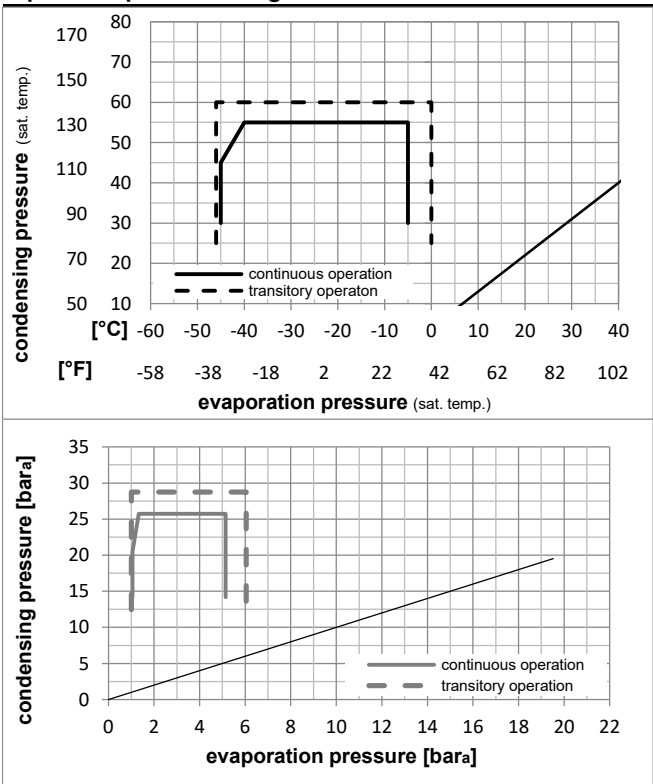

Components (protector + ~holder + cover: pre assembled)

a3	SC starter kit	117-7045
f	ext. protector (T0761/46)	117U3212
b	plastic cover	117U1021

Alternative comp. (protector + ~holder + cover: pre assemb.)

a2	potential relay (RVA 7AA3R)	117-7441
e	run capacitor (23,5µF, 6.3mm)	117-7114
c	start capacitor (410µF, 6.3mm)	117U5043
f	ext. protector (T0761/46)	117U3212
b	plastic cover	117U1021

Model

Designation **SC15CLX.2 115V/60Hz** Conf. **2** Sales code: **104L1853**

Optimization + standard conditions

115V/60Hz, CSCR, fan 3m/s, UL

Evaporating pressure (saturation temperature)														
Condensing pressure (saturation temperature)														
Return gas temp.														
Liquid temp.														
Cooling capacity														
COP														
EER														
Power consumption														
Current consumption														
Ref. mass flow														
	pe	pc	RGT	Tliq	[W]	[Btu/h]	[kcal/h]	[W/W]	[Btu/Wh]	[kcal/Wh]	P1	I	m	
[°C]	[°C]	[°C]	[°C]	[W]	[Btu/h]	[kcal/h]	[W/W]	[Btu/Wh]	[kcal/Wh]	[W]	[A]	[kg/h]		
[°C]	-23,3	54,4	32,2	32,2	873,9	2984	752,1	1,27	4,32	1,09	690,2	7,23	20,36	ASHRAE LBP
[°F]	-10	130	90	90										
[°C]	-25	55	32	55	588,2	2009	506,2	0,89	3,03	0,76	662,5	7,02	18,38	cecomaf LBP
[°F]	-13	131	89,6	131										
[°C]	-35	40	20	40	475,2	1623	409,0	0,98	3,36	0,85	482,6	5,65	12,91	EN12900 LBP
[°F]	-31	104	68	104										
[°C]	-23,3	48,9	4,44	48,9	660,1	2254	568,1	0,98	3,34	0,84	675,8	7,09	23,37	ARI540 LBP
[°F]	-10	120	40	120										
[°C]	-23,3	40,6	32,2	32,2	1010,2	3450	869,4	1,55	5,28	1,33	653,7	6,83	23,54	AHAM LBP
[°F]	-10	105	90	90										
[°C]	-35	45	32	45	433,9	1482	373,4	0,89	3,04	0,77	487,3	5,73	11,60	opt
[°F]	-31	113	89,6	113										

Performance tables

115V/60Hz, CSCR, fan 3m/s, UL

	pe		Cooling capacity			COP		EER		P1	I	m
	[°C]	[°F]	[W]	[Btu/h]	[kcal/h]	[W/W]	[Btu/Wh]	[kcal/Wh]	[W]	[A]	[kg/h]	
[°C / °F]	-45	-49	191,5	654	164,8	0,60	2,03	0,51	321,3	4,88	5,09	
cond. pressure	-34,4	-30	449,9	1536	387,2	0,91	3,10	0,78	496,0	5,78	12,03	
pc= 45/113	-28,9	-20	626,7	2140	539,4	1,08	3,68	0,93	581,4	6,34	16,84	
return gas temp.	-23,3	-10	838,1	2862	721,3	1,26	4,30	1,08	665,7	6,96	22,65	
RGT= 32/90	-20,6	-5	958,3	3273	824,8	1,35	4,62	1,16	708,3	7,30	25,98	
liquid temp	-15	5	1230,8	4203	1059,2	1,55	5,28	1,33	795,9	8,03	33,62	
Tliq= 45/113	-5	23	1842,5	6293	1585,7	1,90	6,49	1,64	969,1	9,54	51,22	
[°C / °F]	-45	-49	91,2	312	78,5	0,32	1,08	0,27	287,7	4,88	2,80	
cond. pressure	-34,4	-30	315,2	1076	271,2	0,64	2,18	0,55	494,0	5,92	9,75	
pc= 55/131	-28,9	-20	465,8	1591	400,9	0,78	2,68	0,67	594,1	6,55	14,49	
return gas temp	-23,3	-10	645,5	2204	555,5	0,93	3,19	0,80	691,6	7,24	20,22	
RGT= 32/90	-20,6	-5	747,7	2554	643,5	1,01	3,45	0,87	740,3	7,60	23,51	
liquid temp	-15	5	980,1	3347	843,4	1,17	3,99	1,01	839,1	8,38	31,08	
Tliq= 55/131	-5	23	1505,6	5142	1295,7	1,46	5,00	1,26	1028,8	9,97	48,73	

Model

Designation	SC15CLX.2	115V/60Hz	Conf. 3	Sales code:	104L1853
-------------	------------------	------------------	----------------	-------------	-----------------

Configuration

Motorconfiguration	CSIR
Power supply (nominal)	115V/60Hz 1~
Refrigerant	R452A
Application	LBP
Voltage range	103-127V
Starting torque	HST
Approvals	UL

Electrical accessories / wiring diagram

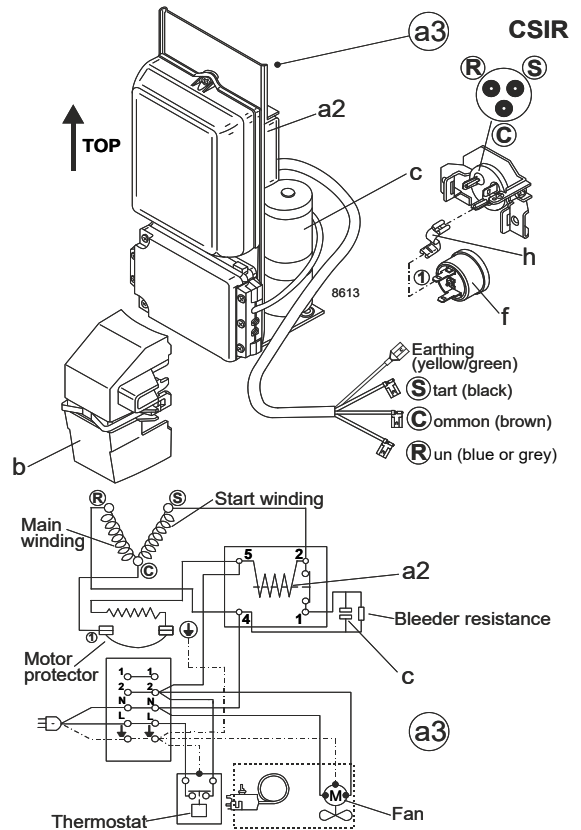

Ambient temperatures / system cooling

Ambient temperature min.:	10°C / 50°F
Ambient temperature max.:	43°C / 110°F

System cooling (n/a: outside limits)			
T ambient	LBP	MBP	HBP
32°C / 90°F	fan 3m/s	n/a	n/a
38°C / 100°F	fan 3m/s	n/a	n/a
43°C / 110°F	fan 3m/s	n/a	n/a

Operation pressure range

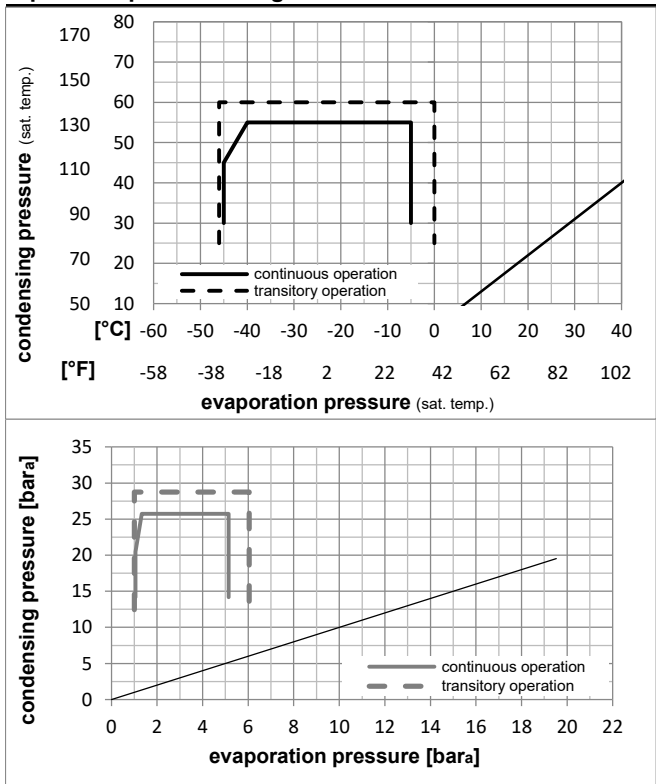

Components (protector + ~holder + cover: pre assembled)

a3	SC starter kit	117-7053
f	ext. protector (T0761/46)	117U3212
h	protector holder	117U0439
b	plastic cover	117U1021

Alternative comp. (protector + ~holder + cover: pre assemb.)

a2	potential relay (RVA 7AA3R)	117-7441
c	start capacitor	117U5042
f	ext. protector (T0761/46)	117U3212
h	protector holder	117U0439
b	plastic cover	117U1021

Model

Designation **SC15CLX.2 115V/60Hz** Conf. **3** Sales code: **104L1853**

Optimization + standard conditions

115V/60Hz, CSIR, fan 3m/s, UL

Evaporating pressure (saturation temperature)														
Condensing pressure (saturation temperature)														
Return gas temp.														
Liquid temp.														
Cooling capacity														
COP														
EER														
Power consumption														
Current consumption														
Ref. mass flow														
	pe	pc	RGT	Tliq	[W]	[Btu/h]	[kcal/h]	[W/W]	[Btu/Wh]	[kcal/Wh]	P1	I	m	
[°C]	[°C]	[°C]	[°C]	[°C]							[W]	[A]	[kg/h]	
[°F]	-23,3	54,4	32,2	32,2	803,7	2745	691,6	1,18	4,05	1,02	678,4	8,93	19,32	ASHRAE LBP
[°F]	-10	130	90	90										
[°C]	-25	55	32	55	545,4	1863	469,3	0,84	2,87	0,72	649,8	8,77	17,35	cecomaf LBP
[°F]	-13	131	89,6	131										
[°C]	-35	40	20	40	430,7	1471	370,7	0,90	3,07	0,77	478,9	7,80	12,03	EN12900 LBP
[°F]	-31	104	68	104										
[°C]	-23,3	48,9	4,44	48,9	617,0	2107	531,0	0,93	3,17	0,80	663,6	8,85	22,18	ARI540 LBP
[°F]	-10	120	40	120										
[°C]	-23,3	40,6	32,2	32,2	935,4	3194	805,0	1,46	4,98	1,25	641,8	8,73	22,48	AHAM LBP
[°F]	-10	105	90	90										
[°C]	-35	45	32	45	392,1	1339	337,4	0,81	2,78	0,70	481,2	7,81	10,76	opt
[°F]	-31	113	89,6	113										

Performance tables

115V/60Hz, CSIR, fan 3m/s, UL

	pe	Cooling capacity			COP	EER	P1	I	m			
		[°C]	[°F]	[W]						[Btu/h]	[kcal/h]	[W/W]
[°C / °F]	-45	-49		164,3	561	141,4	0,47	1,61	0,41	348,3	7,05	4,48
cond. pressure	-34,4	-30		407,2	1391	350,5	0,83	2,84	0,72	488,9	7,85	11,18
pc= 45/113	-28,9	-20		575,9	1967	495,6	1,01	3,46	0,87	568,4	8,31	15,88
return gas temp.	-23,3	-10		779,1	2661	670,5	1,19	4,07	1,03	653,2	8,79	21,59
RGT= 32/90	-20,6	-5		895,1	3057	770,4	1,28	4,38	1,10	698,0	9,05	24,87
liquid temp	-15	5		1159,1	3958	997,5	1,46	4,99	1,26	793,0	9,59	32,42
Tliq= 45/113	-5	23		1754,8	5993	1510,2	1,78	6,08	1,53	985,8	10,69	49,86
[°C / °F]	-45	-49		73,2	250	63,0	0,23	0,79	0,20	315,1	6,86	2,29
cond. pressure	-34,4	-30		283,4	968	243,9	0,58	1,99	0,50	487,2	7,84	8,94
pc= 55/131	-28,9	-20		427,4	1460	367,8	0,74	2,51	0,63	581,5	8,38	13,55
return gas temp	-23,3	-10		600,7	2052	517,0	0,88	3,02	0,76	679,8	8,94	19,15
RGT= 32/90	-20,6	-5		699,9	2390	602,3	0,96	3,27	0,82	730,8	9,23	22,39
liquid temp	-15	5		926,2	3163	797,1	1,11	3,78	0,95	837,5	9,84	29,85
Tliq= 55/131	-5	23		1441,1	4922	1240,2	1,38	4,70	1,18	1047,9	11,04	47,30

Model

Designation	SC15CLX.2	115V/60Hz	Conf. 4	Sales code:	104L1853
-------------	------------------	------------------	----------------	-------------	-----------------

Configuration

Motorconfiguration	CSCR
Power supply (nominal)	115V/60Hz 1~
Refrigerant	R452A
Application	LBP
Voltage range	103-127V
Starting torque	HST
Approvals	UL

Electrical accessories / wiring diagram

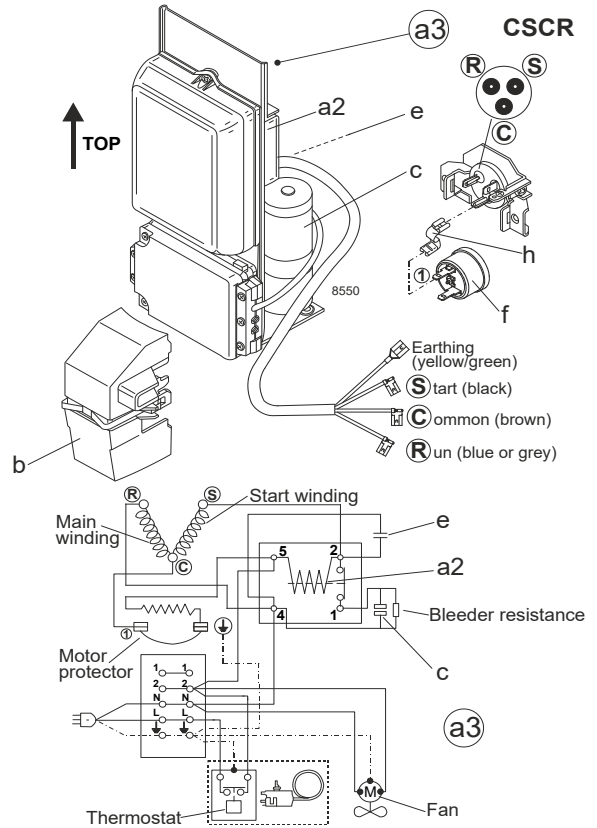

Ambient temperatures / system cooling

Ambient temperature min.:	10°C / 50°F
Ambient temperature max.:	43°C / 110°F

System cooling (n/a: outside limits)			
T ambient	LBP	MBP	HBP
32°C / 90°F	fan 3m/s	n/a	n/a
38°C / 100°F	fan 3m/s	n/a	n/a
43°C / 110°F	fan 3m/s	n/a	n/a

Operation pressure range

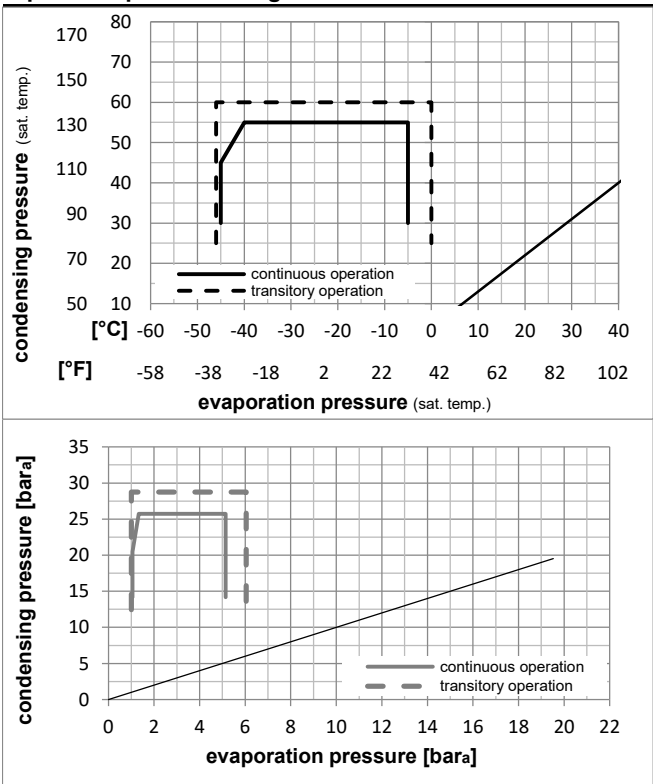

Components (protector + ~holder + cover: pre assembled)

a3	SC starter kit	117-7045
f	ext. protector (T0761/46)	117U3212
b	plastic cover	117U1021

Alternative comp. (protector + ~holder + cover: pre assemb.)

a2	potential relay (RVA 7AA3R)	117-7441
e	run capacitor (23,5µF, 6.3mm)	117-7114
c	start capacitor (410µF, 6.3mm)	117U5043
f	ext. protector (T0761/46)	117U3212
b	plastic cover	117U1021

Model

Designation **SC15CLX.2 115V/60Hz** Conf. **4** Sales code: **104L1853**

Optimization + standard conditions

115V/60Hz, CSCR, fan 3m/s, UL

Evaporating pressure (saturation temperature)														
Condensing pressure (saturation temperature)														
Return gas temp.														
Liquid temp.														
Cooling capacity														
COP														
EER														
Power consumption														
Current consumption														
Ref. mass flow														
	pe	pc	RGT	Tliq	[W]	[Btu/h]	[kcal/h]	[W/W]	[Btu/Wh]	[kcal/Wh]	P1	I	m	
[°C]	[°C]	[°C]	[°C]	[°C]							[W]	[A]	[kg/h]	
[°F]	-23,3	54,4	32,2	32,2	797,9	2725	686,7	1,24	4,24	1,07	643,1	6,90	19,18	ASHRAE LBP
[°F]	-10	130	90	90										
[°C]	-25	55	32	55	541,5	1849	466,0	0,88	3,01	0,76	615,3	6,70	17,23	cecomaf LBP
[°F]	-13	131	89,6	131										
[°C]	-35	40	20	40	428,2	1462	368,5	0,96	3,29	0,83	444,5	5,42	11,96	EN12900 LBP
[°F]	-31	104	68	104										
[°C]	-23,3	48,9	4,44	48,9	612,5	2092	527,1	0,97	3,31	0,84	631,1	6,77	22,02	ARI540 LBP
[°F]	-10	120	40	120										
[°C]	-23,3	40,6	32,2	32,2	928,6	3171	799,2	1,52	5,18	1,31	611,7	6,52	22,32	AHAM LBP
[°F]	-10	105	90	90										
[°C]	-35	45	32	45	389,6	1331	335,3	0,87	2,98	0,75	447,1	5,48	10,69	opt
[°F]	-31	113	89,6	113										

Performance tables

115V/60Hz, CSCR, fan 3m/s, UL

	pe	Cooling capacity			COP	EER	P1	I	m			
		[°C]	[°F]	[W]						[Btu/h]	[kcal/h]	[W/W]
[°C / °F]	-45	-49		162,9	556	140,2	0,57	1,93	0,49	287,5	4,73	4,45
cond. pressure	-34,4	-30		404,7	1382	348,3	0,89	3,03	0,76	455,6	5,53	11,11
pc= 45/113	-28,9	-20		571,9	1953	492,2	1,06	3,62	0,91	539,1	6,05	15,77
return gas temp.	-23,3	-10		773,4	2641	665,6	1,24	4,24	1,07	622,3	6,65	21,43
RGT= 32/90	-20,6	-5		888,6	3035	764,7	1,34	4,57	1,15	664,6	6,97	24,69
liquid temp	-15	5		1151,0	3931	990,6	1,53	5,23	1,32	752,2	7,68	32,20
Tliq= 45/113	-5	23		1745,3	5961	1502,0	1,88	6,43	1,62	926,5	9,14	49,59
[°C / °F]	-45	-49		72,3	247	62,2	0,29	0,99	0,25	249,9	4,73	2,27
cond. pressure	-34,4	-30		281,7	962	242,4	0,63	2,14	0,54	449,5	5,67	8,89
pc= 55/131	-28,9	-20		424,5	1450	365,3	0,78	2,65	0,67	547,6	6,25	13,46
return gas temp	-23,3	-10		596,4	2037	513,3	0,93	3,16	0,80	644,3	6,90	19,01
RGT= 32/90	-20,6	-5		694,9	2373	598,0	1,00	3,43	0,86	692,8	7,26	22,23
liquid temp	-15	5		920,0	3142	791,8	1,16	3,97	1,00	791,9	8,01	29,66
Tliq= 55/131	-5	23		1434,4	4899	1234,4	1,46	4,98	1,25	983,8	9,55	47,08



SC Compressors (External Protector)

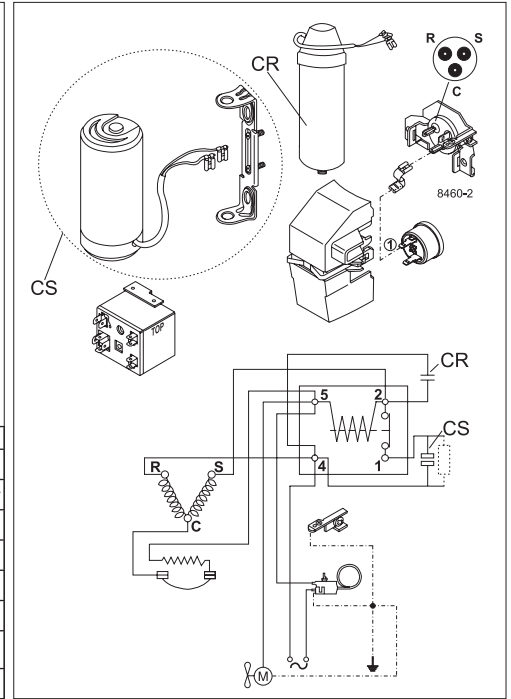
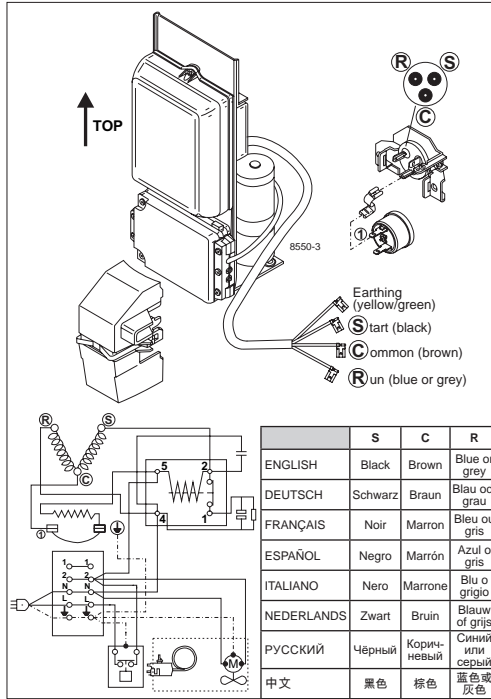
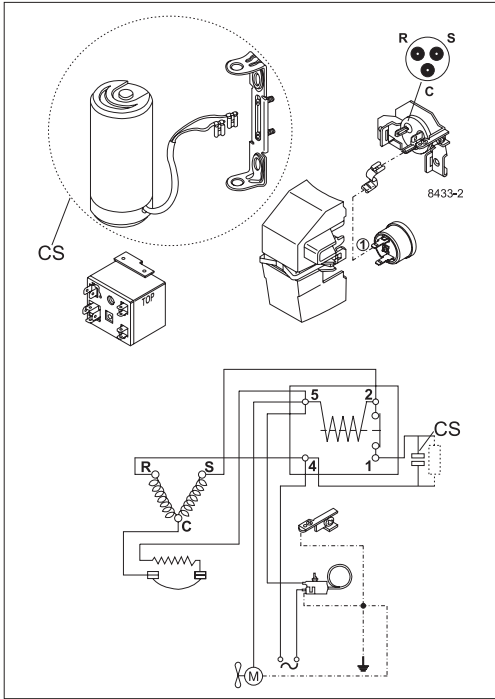



SC Compressors (External Protector)



Service/Repair – R290



8545



Secop accepts no responsibility for possible errors in catalogs, brochures, and other printed material. Secop reserves the right to alter its products without notice. This also applies to products already on order provided that such alterations can be made without subsequent changes being necessary to specifications already agreed. All trademarks in this material are the property of the respective companies. Secop and the Secop logotype are trademarks of Secop GmbH. All rights reserved. www.secop.com