

Single Pack MS21UDULTM 220-240V 50Hz CSCR

Codice Imballo Singolo: **195B4691**

Posizione	Titolo	Codice	Quantità
1	Compressor MS21UDULTM	104M0811	1
2	SC starting device (550mm)	117-7816	1
3	Bolt joint for one compressor M6 ø16mm	118-1917	1

Secop GmbH • Lise-Meitner-Straße 29 • 24941 Flensburg, Germany • Tel: +49 46149410 • www.secop.com

Secop non si assume alcuna responsabilità per eventuali errori presenti in cataloghi, brochure e altro materiale stampato. Secop si riserva il diritto di modificare i propri prodotti senza preavviso. Ciò vale anche per i prodotti già ordinati, a condizione che tali modifiche possano essere apportate senza che siano necessarie modifiche successive alle specifiche già concordate. Tutti i marchi presenti in questo materiale sono di proprietà delle rispettive aziende. Secop e il logo Secop sono marchi di Secop GmbH. Tutti i diritti sono riservati.

ULT - ready

Model

Designation	MS21UDULTM	220-240V/50Hz 1~	Sales code:	104M0811
-------------	-------------------	------------------	-------------	-----------------

Compressor design

Oil type	Polyolester	Refrigerant(s)	R170, R508B
Oil viscosity	32cST	Displacement	20,95cm ³ / 1,28cu.in
Oil quantity	620cm ³ / 21fl.oz	Compressors on pallet	80
Refr. charge - tech. limit	500g / 17,6oz		
Free gas volume comp.	1460cm ³ / 49,4fl.oz		
Weight	14,2kg / 31,3lbs		
Motor protection	external		
Winding resistance main	4,09Ω (at 25°C)		
Winding resistance aux	13,46Ω (at 25°C)		
Max. winding temp.	135°C / 275°F		
Max. discharge temp.	140°C / 284°F		



General - Configurations with MS21UDULTM

	Conf. 1
Motorconfiguration	CSCR
Power supply (nominal)	220-240V/50Hz
Number of phases	1
Voltage range	198-254V
Approvals	Chem.-comp.
Starting torque	HST
Note	ULT-ready. Compressor for low-temp-stage of cascade refrigeration systems.

Applications with MS21UDULTM

	Conf. 1
Refrigerant	R170
Application	LBP
System cooling	fan 3m/s
Hot gas defrost	-/-
Long interval pull down	-/-

Electrical data - Configurations with MS21UDULTM

	Conf. 1
Starting device type	relay
Run capacitor	10μF
Start capacitor	60μF
LRA (locked rotor amps / 4s)	18,16A
RLA (rated load amps / 1s)	2,95A
Cut in current	18,16A

ULT - ready

Model

Designation **MS21UDULTM** 220-240V/50Hz 1~

Sales code: **104M0811**

Compressor dimensions

Housing	A Height	219mm / 8,62in
	B Height	213mm / 8,39in
	C Length shell	218mm / 8,58in
	D Length w. cover	255mm / 10,04in
	E Width	151mm / 5,94in

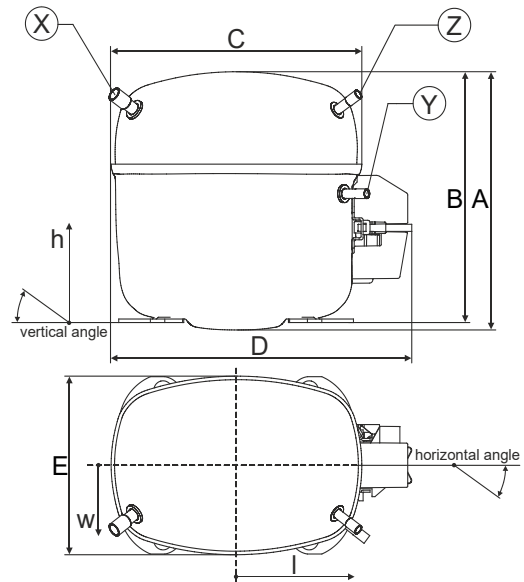

Connectors		Suction	Discharge	Process
		X	Y	Z
Diameter	[mm]	øi 10,11-10,29	øi 6,11-6,29	øi 6,11-6,29
(i:inside, o:outside)	[in]	øi 0,4-0,41	øi 0,24-0,25	øi 0,24-0,25
Material		copper	copper	copper
Horizontal angle	±2°	37°	37°	143°
Vertical angle	±2°	30°	0°	150°
Position l/h/w	[mm]	107/193/55	115/110/63	-107/193/55
	[in]	4,2/7,6/2,2	4,5/4,3/2,5	-4,2/7,6/2,2
Straight tube l.	[mm]	12	12	12
	[in]	0,5	0,5	0,5

Compressor fixation

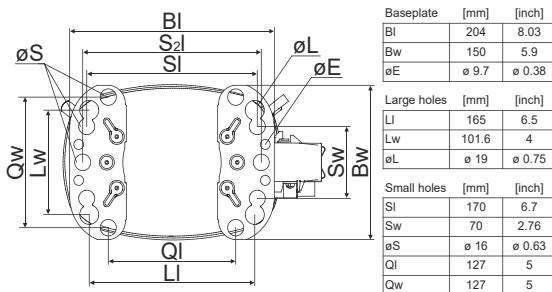

Bolt joint

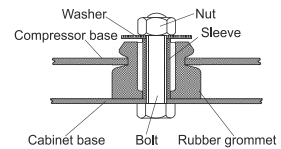

Snap-on

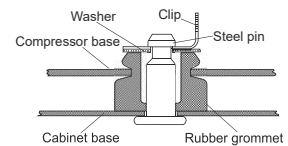

Mounting accessories

	one comp.	multi pack
Bolt joint M6 ø16mm	118-1917	118-1918
Bolt joint ø1/4" ø16mm	118-1946	
Bolt joint ø1/4" ø19mm	118-1949	
Snap-on ø7,3 ø16mm	118-1947	118-1919

Application notes

ULT-ready. Compressor for low-temp-stage of cascade refrigeration systems.

No warranty if compressor operated relevant time outside of published operation limits.

Contact SECOP-Sales to agree on warranty limits (depends on kind of application).

ULT - ready

Model

Designation

MS21UDULTM 220-240V/50Hz

Conf. 1

Sales code:

104M0811

Configuration

Motorconfiguration	CSCR
Power supply (nominal)	220-240V/50Hz 1~
Refrigerant	R170
Application	LBP
Voltage range	198-254V
Starting torque	HST
Approvals	Chem.-comp.

Electrical accessories / wiring diagram

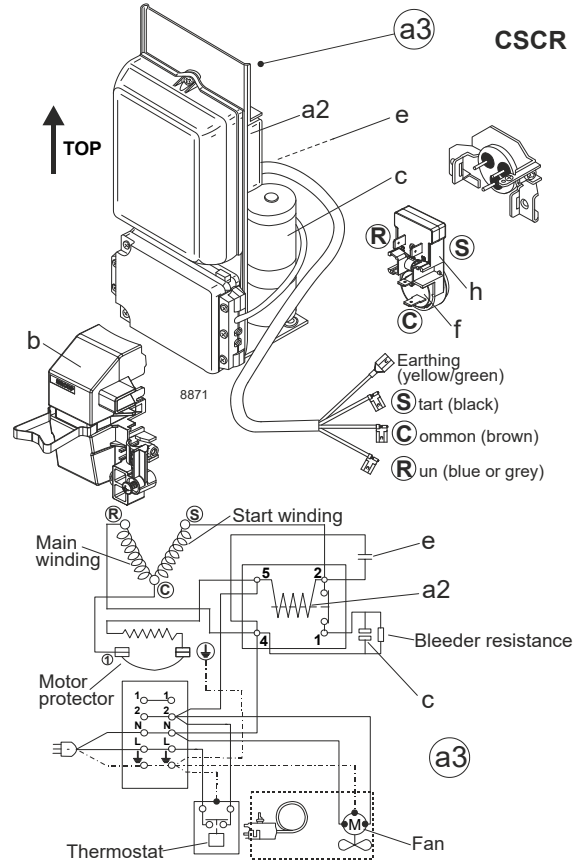

Ambient temperatures / system cooling

Ambient temperature min.:	10°C / 50°F
Ambient temperature max.:	38°C / 101°F

System cooling (n/a: outside limits)			
T ambient	LBP	MBP	HBP
32°C / 90°F	fan 3m/s	n/a	n/a
38°C / 100°F	fan 3m/s	n/a	n/a
43°C / 110°F	n/a	n/a	n/a

Operation pressure range

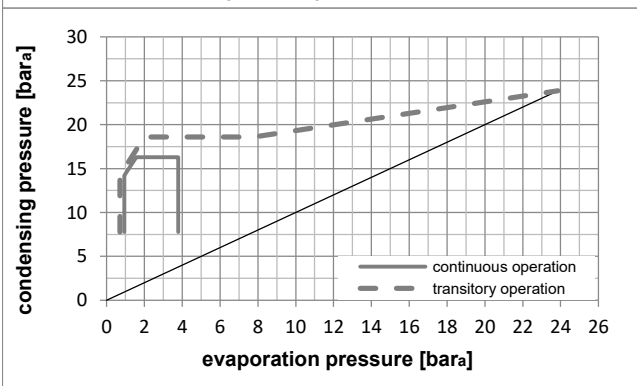
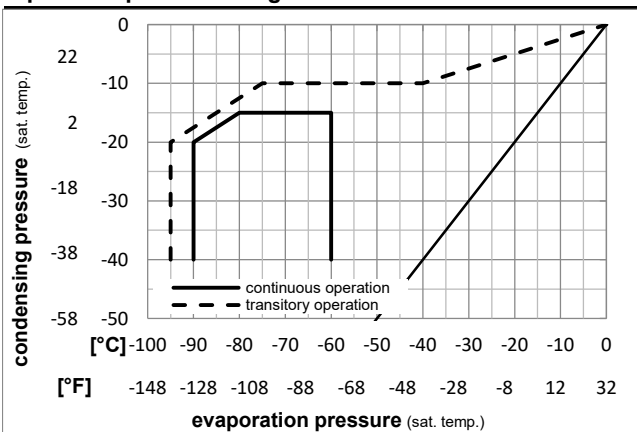

Components (protector + ~holder + cover: pre assembled)

a3	SC starter kit (550mm)	117-7816
f / h	motor protector assy. (T1102)	117U8001
b	plastic cover	117U1028

Alternative comp. (protector + ~holder + cover: pre assemb.)

a2	potential relay (RVA 4I3R A57)	117-7600
e	run capacitor (10µF, 6.3mm)	117-7112
c	start capacitor (60µF, 6.3mm)	117U5389
f / h	motor protector assy. (T1102)	117U8001
b	plastic cover	117U1028

ULT - ready

Model

Designation	MS21UDULTM 220-240V/50Hz	Conf. 1	Sales code: 104M0811
-------------	---------------------------------	---------	-----------------------------

Optimization + standard conditions

R170, 220V/50Hz, CSCR, fan 3m/s, Chem.-comp.

Evaporating pressure (saturation temperature)					Condensing pressure (saturation temperature)					Power consumption				
					Return gas temp.					Current consumption				
					Liquid temp.					Ref. mass flow				
					Cooling capacity					COP EER				
pe	pc	RGT	Tliq		[W]	[Btu/h]	[kcal/h]	[W/W]	[Btu/Wh]	[kcal/Wh]	P1	I	m	
[°C]	[°C]		[°C]	[°C]							[W]	[A]	[kg/h]	
-90	-15	-20	-15		226,2	773	194,7	0,83	2,83	0,71	273,1	1,51	2,07	1
-130	5	-4	5											
[°F]														
-90	-20	-20	-20		256,6	876	220,8	0,93	3,17	0,80	276,8	1,52	2,26	2
-130	-4	-4	-4											
[°F]														
-90	-25	-20	-25		288,8	986	248,5	1,05	3,58	0,90	275,6	1,52	2,45	3
-130	-13	-4	-13											
[°F]														
-90	-30	-20	-30		322,3	1101	277,4	1,19	4,08	1,03	269,8	1,49	2,65	4
-130	-22	-4	-22											
[°F]														
-90	-35	-20	-35		356,4	1217	306,7	1,37	4,69	1,18	259,5	1,45	2,83	5
-130	-31	-4	-31											
[°F]														
-90	-40	-20	-40		390,6	1334	336,2	1,60	5,45	1,37	244,9	1,40	3,01	6
-130	-40	-4	-40											
[°F]														

Performance tables

R170, 220V/50Hz, CSCR, fan 3m/s, Chem.-comp.

	pe	Cooling capacity			COP			EER			P1	I	m
	[°C]	[°F]	[W]	[Btu/h]	[kcal/h]	[W/W]	[Btu/Wh]	[kcal/Wh]	[W]	[A]	[kg/h]		
[°C / °F]	-90	-130	288,8	986	248,5	1,05	3,58	0,90	275,6	1,52	2,45		
cond. pressure	-85	-121	426,1	1455	366,7	1,29	4,40	1,11	331,1	1,73	3,62		
pc= -25/-13	-80	-112	596,0	2036	512,9	1,54	5,26	1,33	386,7	1,96	5,08		
return gas temp.	-75	-103	802,4	2740	690,5	1,82	6,22	1,57	440,5	2,19	6,86		
RGT= -20/-4	-70	-94	1048,7	3582	902,5	2,14	7,30	1,84	490,6	2,41	9,00		
liquid temp	-65	-85	1338,6	4571	1152,0	2,50	8,54	2,15	535,1	2,61	11,53		
Tliq= -25/-13	-60	-76	1675,2	5721	1441,7	2,93	10,00	2,52	572,1	2,77	14,49		
[°C / °F]	-90	-130	356,4	1217	306,7	1,37	4,69	1,18	259,5	1,45	2,83		
cond. pressure	-85	-121	502,8	1717	432,8	1,65	5,63	1,42	305,1	1,63	4,00		
pc= -35/-31	-80	-112	684,4	2337	589,0	1,97	6,72	1,69	348,1	1,80	5,46		
return gas temp	-75	-103	904,9	3090	778,8	2,34	8,00	2,02	386,4	1,96	7,24		
RGT= -20/-4	-70	-94	1168,0	3989	1005,2	2,79	9,54	2,40	418,2	2,10	9,37		
liquid temp	-65	-85	1477,2	5045	1271,3	3,34	11,42	2,88	441,6	2,20	11,89		
Tliq= -35/-31	-60	-76	1835,9	6270	1580,0	4,04	13,79	3,47	454,7	2,25	14,85		

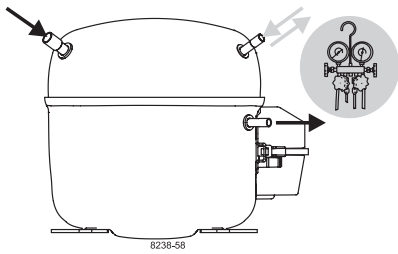

SCE Compressors

(External Protector)

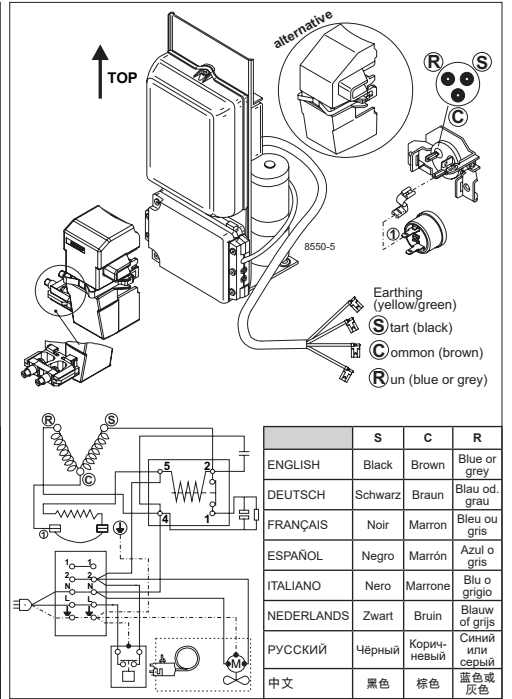
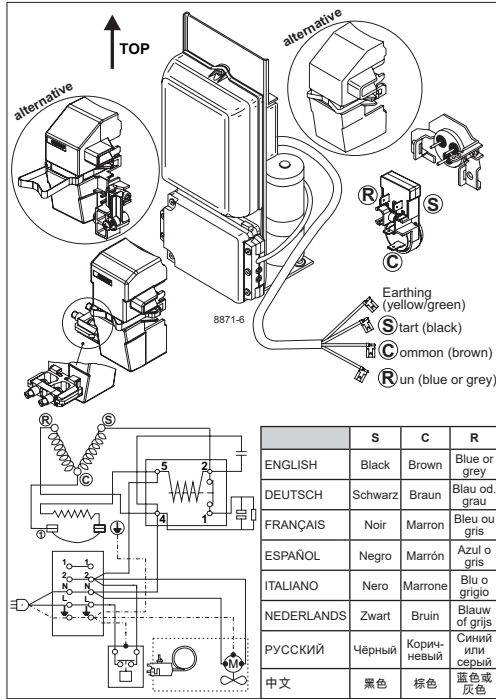
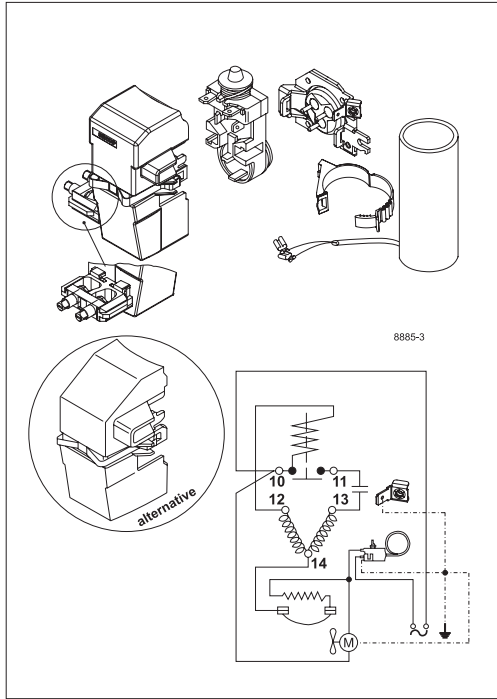

	S	C	R
ENGLISH	Black	Brown	Blue or grey
DEUTSCH	Schwarz	Braun	Blau od. grau
FRANÇAIS	Noir	Marron	Bleu ou gris
ESPAÑOL	Negro	Marrón	Azul o gris
ITALIANO	Nero	Marrone	Blu o grigio
NEDERLANDS	Zwart	Bruin	Blauw of grijs
РУССКИЙ	Чёрный	Коричневый	Синий или серый
中文	黑色	棕色	蓝色或灰色

	S	C	R
ENGLISH	Black	Brown	Blue or grey
DEUTSCH	Schwarz	Braun	Blau od. grau
FRANÇAIS	Noir	Marron	Bleu ou gris
ESPAÑOL	Negro	Marrón	Azul o gris
ITALIANO	Nero	Marrone	Blu o grigio
NEDERLANDS	Zwart	Bruin	Blauw of grijs
РУССКИЙ	Чёрный	Коричневый	Синий или серый
中文	黑色	棕色	蓝色或灰色

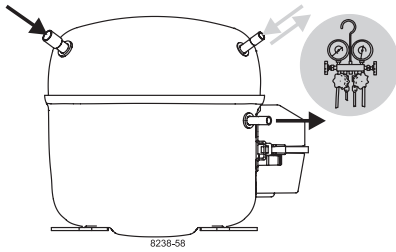

SCE Compressors (External Protector)



Service/Repair – R290

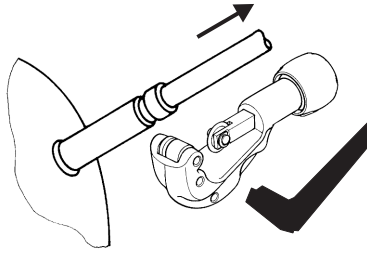
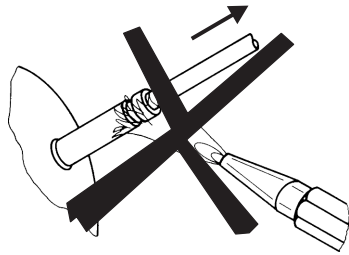

8545

Brazing on Suction Connectors (Direct Intake)

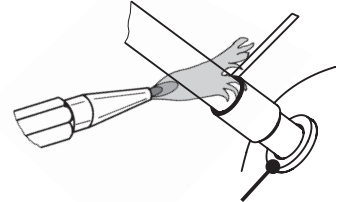

**! max. 350°C/662°F !
at socket**
brazing solder: phosphor (LP7) or silver

8682

Refer to Product Bulletin:
Brazing on Suction Connectors
(SCE Compressors with Direct Suction Intake)

Secop accepts no responsibility for possible errors in catalogs, brochures, and other printed material. Secop reserves the right to alter its products without notice. This also applies to products already on order provided that such alterations can be made without subsequential changes being necessary to specifications already agreed. All trademarks in this material are the property of the respective companies. Secop and the Secop logotype are trademarks of Secop GmbH. All rights reserved. www.secop.com