

Single Pack KLF6.6CNH 115-127V 60Hz CSIR

Codice Imballo Singolo: **195B4701**

Posizione	Titolo	Codice	Quantità
1	Compressor KLF6.6CNH	106H3710	1
2	Bolt joint for one compressor M6 ø16mm	118-1917	1

Secop GmbH • Lise-Meitner-Straße 29 • 24941 Flensburg, Germany • Tel: +49 46149410 • www.secop.com

Secop non si assume alcuna responsabilità per eventuali errori presenti in cataloghi, brochure e altro materiale stampato. Secop si riserva il diritto di modificare i propri prodotti senza preavviso. Ciò vale anche per i prodotti già ordinati, a condizione che tali modifiche possano essere apportate senza che siano necessarie modifiche successive alle specifiche già concordate. Tutti i marchi presenti in questo materiale sono di proprietà delle rispettive aziende. Secop e il logo Secop sono marchi di Secop GmbH. Tutti i diritti sono riservati.

Model

Designation	KLF6.6CNH	115-127V/60Hz 1~	Sales code:	106H3710
-------------	------------------	------------------	-------------	-----------------

Compressor design

Oil type	Polyolester	Refrigerant(s)	R290
Oil viscosity	10,4cSt	Displacement	6,6cm ³ / 0,4cu.in
Oil quantity	174cm ³ / 5,9fl.oz	Compressors on pallet	100
Refr. charge - tech. limit	200g / 7,1oz		
Free gas volume comp.	1580cm ³ / 53,4fl.oz		
Weight	9,5kg / 20,9lbs		
Motor protection	external		
Winding resistance main	2Ω (at 25°C)		
Winding resistance aux	5,3Ω (at 25°C)		
Max. winding temp.	125°C / 257°F		
Max. discharge temp.	130°C / 266°F		



General - Configurations with KLF6.6CNH

	Conf. 1
Motorconfiguration	CSIR
Power supply (nominal)	115-127V/60Hz
Number of phases	1
Voltage range	95-140V
Approvals	UL, CCC
Starting torque	HST
Note	Electrical equipment is included and pre-assembled to compressor.

Applications with KLF6.6CNH

	Conf. 1
Refrigerant	R290
Application	LBP+MBP
System cooling	fan 3m/s
Hot gas defrost	OK
Long interval pull down	OK

Electrical data - Configurations with KLF6.6CNH

	Conf. 1
Starting device type	relay
Run capacitor	-/-
Start capacitor	240μF
LRA (locked rotor amps / 4s/ U(N))	31,1A
RLA (rated load amps / 1s/ U(N))	4,3A
Cut in current (U(N))	27,8A

Model

Designation	KLF6.6CNH	115-127V/60Hz 1~	Sales code:	106H3710
-------------	------------------	------------------	-------------	-----------------

Compressor dimensions

Housing	A Height	182mm / 7,17in
	B Height	175mm / 6,89in
	C Length shell	198mm / 7,8in
	D Length w. cover	238mm / 9,37in
	E Width	160mm / 6,3in

Connectors		Suction	Discharge	Process
		X	Y	Z
Diameter	[mm]	øi 8,11-8,29	øi 6,41-6,59	øi 6,41-6,59
(i:inside, o:outside)	[in]	øi 0,32-0,33	øi 0,25-0,26	øi 0,25-0,26
Material		copper	copper	copper
Horizontal angle	±2°	35°	13°	0°
Vertical angle	±2°	30°	40°	145°
Position l/h/w	[mm]	119/73/59	117/107/66	-88/101/71
	[in]	4,7/2,9/2,3	4,6/4,2/2,6	-3,5/4/2,8
Straight tube l.	[mm]	14	14	14
	[in]	0,5	0,5	0,5

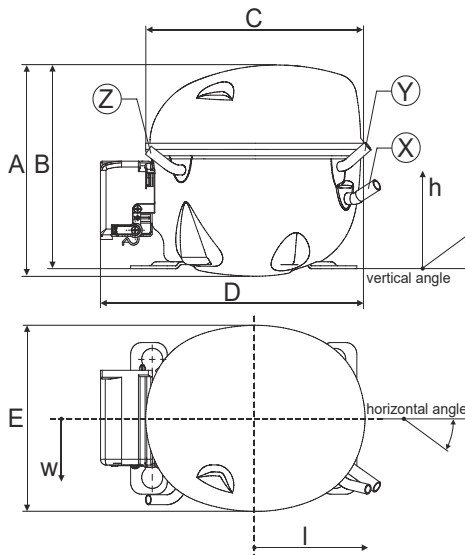

Compressor fixation

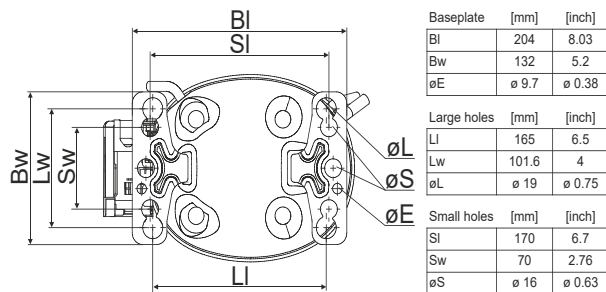

Bolt joint



Snap-on

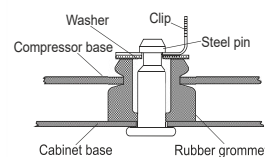

Mounting accessories	one comp.	multi pack
Bolt joint M6 ø16mm	118-1917	118-1918
Bolt joint ø1/4" ø16mm	118-1946	
Bolt joint ø1/4" ø19mm	118-1949	
Snap-on ø7,3 ø16mm	118-1947	118-1919

Application notes

Operation possible until tilted up to 3 degrees

Provision for PE Grounding is located at the PE Stamp on the compressor

Model

Designation	KLF6.6CNH	115-127V/60Hz	Conf. 1	Sales code:	106H3710
-------------	------------------	----------------------	----------------	-------------	-----------------

Configuration

Motorconfiguration	CSIR
Power supply (nominal)	115-127V/60Hz 1~
Refrigerant	R290
Application	LBP+MBP
Voltage range	95-140V
Starting torque	HST
Approvals	UL CCC

Electrical accessories / wiring diagram

CSIR



Ambient/ machine room temperatures minimum /maximum

Ambient temperature range:	10 - 43°C / 50 - 110°F
Machine room temperature range:	10 - 48°C / 50 - 119°F
Compressor cooling:	fan 3m/s

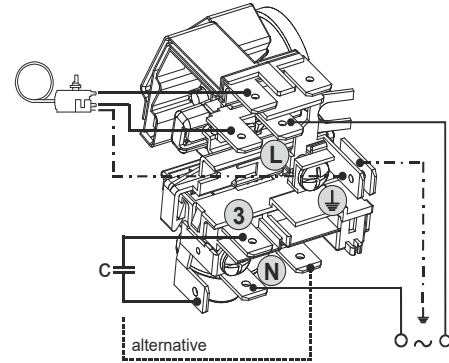

Operation pressure range

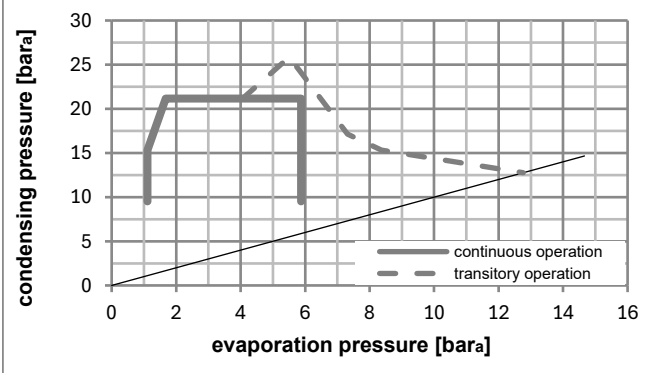
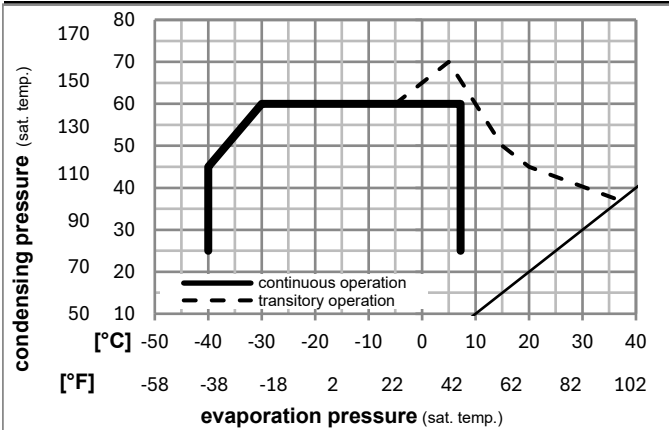

Components (already pre-assembled)

a5	current relay (T1141/L6-S6)	117U7076
c	start capacitor (240µF)	117U5002
.	cable clamp	16058100
b	cover terminal board	10636401
.	screw uni en iso 4757	10641201
.	screw - uni6954	10636000

Alternative comp. (already pre-assembled)

.	screw - uni6954	10636200
---	-----------------	----------

Model

Designation **KLF6.6CNH** **115-127V/60Hz** Conf. 1 Sales code: **106H3710**

Optimization + standard conditions

R290, 115V/60Hz, CSIR, fan 3m/s, UL, CCC

	Evaporating pressure (saturation temperature)				Cooling capacity			COP	EER	Power consumption			ASHRAE	
	pe	pc	RGT	Tliq	[W]	[Btu/h]	[kcal/h]			P1	I	m		
	[°C]	[°C]	[°C]	[°C]				[W/W]	[Btu/Wh]	[kcal/Wh]	[W]	[A]	[kg/h]	
	-23	54	32	32	396,9	1355	341,6	1,61	5,51	1,39	246,0	3,18	4,02	ASHRAE LBP
	[°F]													
	-10	130	90	90										
	-25	55	32	55	297,2	1015	255,8	1,26	4,30	1,08	236,1	3,13	3,70	cecomaf LBP
	[°F]													
	-13	131	90	131										
	-35	40	20	40	224,4	766	193,1	1,20	4,11	1,04	186,5	2,89	2,56	EN12900 LBP
	[°F]													
	-31	104	68	104										
	-7	54	35	46	717,6	2451	617,6	2,08	7,09	1,79	345,8	3,84	8,19	ASHRAE MBP
	[°F]													
	20	130	95	115										
	-10	55	32	55	567,9	1940	488,8	1,73	5,90	1,49	328,5	3,72	7,18	cecomaf MBP
	[°F]													
	14	131	90	131										
	-10	45	20	45	639,3	2183	550,2	2,06	7,02	1,77	311,0	3,60	7,85	EN12900 MBP
	[°F]													
	14	113	68	113										

Performance tables

R290, 115V/60Hz, CSIR, fan 3m/s, UL, CCC

	pe		Cooling capacity			COP	EER	P1	I	m	
	[°C]	[°F]	[W]	[Btu/h]	[kcal/h]						
[°C / °F]	-40	-40	161,8	553	139,2	0,99	3,37	0,85	163,8	2,80	1,81
cond. pressure	-34	-30	220,5	753	189,8	1,17	4,00	1,01	188,3	2,89	2,47
pc= 45/113	-23	-10	381,3	1302	328,2	1,56	5,33	1,34	244,5	3,18	4,31
return gas temp.	-15	5	546,0	1865	469,9	1,90	6,49	1,64	287,3	3,44	6,21
RGT= 32/90	-4	25	834,7	2851	718,3	2,48	8,48	2,14	336,2	3,77	9,62
liquid temp	0	32	956,4	3266	823,1	2,74	9,35	2,36	349,3	3,87	11,09
Tliq= 45/113	7,2	45	1213,8	4145	1044,6	3,32	11,34	2,86	365,7	3,99	14,26
[°C / °F]	-40	-40	139,9	478	120,4	0,92	3,14	0,79	152,3	2,74	1,73
cond. pressure	-34	-30	186,9	638	160,9	1,04	3,54	0,89	180,6	2,84	2,31
pc= 55/131	-23	-10	321,1	1097	276,3	1,30	4,45	1,12	246,4	3,19	4,00
return gas temp	-15	5	463,1	1582	398,6	1,55	5,30	1,34	298,4	3,52	5,82
RGT= 32/90	-4	25	717,9	2452	617,9	1,98	6,77	1,71	362,3	3,97	9,16
liquid temp	0	32	826,9	2824	711,6	2,17	7,40	1,87	381,3	4,11	10,62
Tliq= 55/131	7,2	45	1059,1	3617	911,5	2,58	8,83	2,22	409,7	4,33	13,80

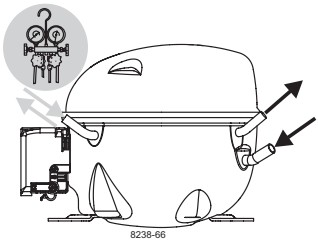

KL Compressors

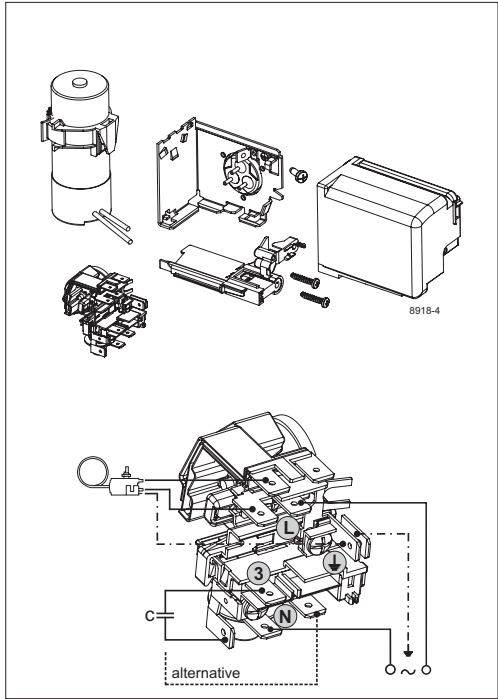
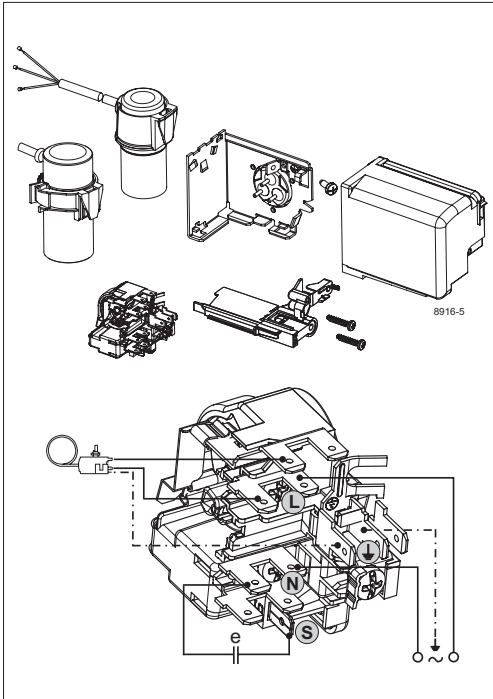
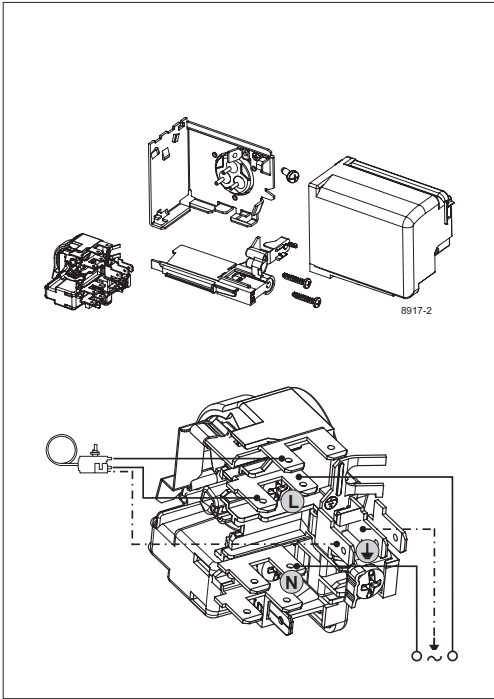

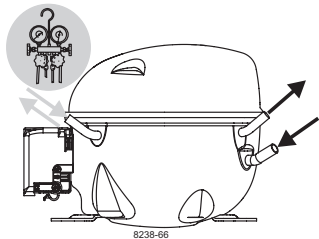

KL Compressors



Service/Repair – R290

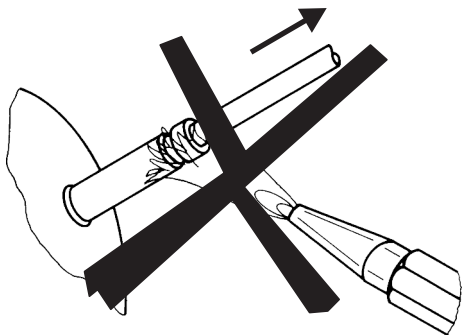

8545

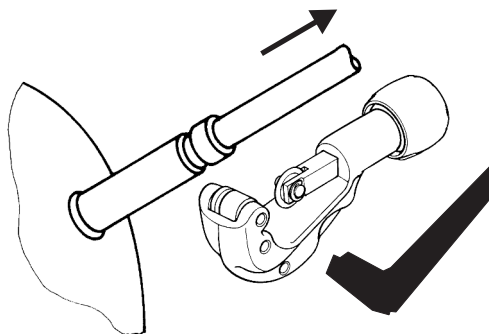

Secop accepts no responsibility for possible errors in catalogs, brochures, and other printed material. Secop reserves the right to alter its products without notice. This also applies to products already on order provided that such alterations can be made without subsequent changes being necessary to specifications already agreed. All trademarks in this material are the property of the respective companies. Secop and the Secop logotype are trademarks of Secop GmbH. All rights reserved. www.secop.com