

## Single Pack KLE4.8GFTX 220-240V 50Hz / 208-230V 60Hz CSIR

Codice Imballo Singolo: **195B4759**

Posizione	Titolo	Codice	Quantità
1	Compressor KLE4.8GFTX	106G5503	1
2	Starting capacitor (80 $\mu$ F 220V, 6.3mm)	117U5001	1
3	Starting relay (QLZ-4.6A, overload protector T1189/L6)	117U7073	1
4	KL accessories	103N1060	1
5	Bolt joint for one compressor   M6   $\varnothing$ 16mm	118-1917	1

**Secop GmbH** • Lise-Meitner-Straße 29 • 24941 Flensburg, Germany • Tel: +49 46149410 • [www.secop.com](http://www.secop.com)

Secop non si assume alcuna responsabilità per eventuali errori presenti in cataloghi, brochure e altro materiale stampato. Secop si riserva il diritto di modificare i propri prodotti senza preavviso. Ciò vale anche per i prodotti già ordinati, a condizione che tali modifiche possano essere apportate senza che siano necessarie modifiche successive alle specifiche già concordate. Tutti i marchi presenti in questo materiale sono di proprietà delle rispettive aziende. Secop e il logo Secop sono marchi di Secop GmbH. Tutti i diritti sono riservati.

## Model

Designation	<b>KLE4.8GFTX</b>	220-240V/50Hz 1~ 208-230V/60Hz 1~	Sales code:	<b>106G5503</b>
-------------	-------------------	-----------------------------------	-------------	-----------------

## Compressor design

Oil type	Polyolester	Refrigerant(s)	<b>R134a, R513A</b>
Oil viscosity	19,2cSt	Displacement	4,8cm <sup>3</sup> / 0,29cu.in
Oil quantity	240cm <sup>3</sup> / 8,1fl.oz	Compressors on pallet	100
Refr. charge - tech. limit	250g / 8,8oz		
Free gas volume comp.	1545cm <sup>3</sup> / 52,2fl.oz		
Weight	9,3kg / 20,5lbs		
Motor protection	external		
Winding resistance main	13,1Ω (at 25°C)		
Winding resistance aux	25,3Ω (at 25°C)		
Max. winding temp.	125°C / 257°F		
Max. discharge temp.	130°C / 266°F		
Additional note	Good robustness against liquid intake. Ice-cube maker optimization - indirect suction intake.		



## General - Configurations with KLE4.8GFTX

	<b>Conf. 1</b>	<b>Conf. 2</b>
Motorconfiguration	CSIR	CSIR
Power supply (nominal)	220-240V/50Hz	208-230V/60Hz
Number of phases	1	1
Voltage range	187-254V	198-253V
Approvals	VDE, (UL,CB) in progress	VDE, (UL,CB) in progress
Starting torque	HST	HST
Note	- / -	

## Applications with KLE4.8GFTX

	<b>Conf. 1</b>	<b>Conf. 2</b>
Refrigerant	R134a	R134a
Application	LBP+MBP+HBP	LBP+MBP
System cooling	fan 3m/s	fan 3m/s
Hot gas defrost	OK	OK
Long interval pull down	OK	OK

## Electrical data - Configurations with KLE4.8GFTX

	<b>Conf. 1</b>	<b>Conf. 2</b>
Starting device type	relay	relay
Run capacitor	-/-	-/-
Start capacitor	80μF	80μF
LRA (locked rotor amps / 4s/ U(N))	10,2A	
RLA (rated load amps / 1s/ U(N))	1,4A	
Cut in current (U(N))	10,2A	

## Model

Designation	<b>KLE4.8GFTX</b>	220-240V/50Hz 1~ 208-230V/60Hz 1~	Sales code:	<b>106G5503</b>
-------------	-------------------	-----------------------------------	-------------	-----------------

## Compressor dimensions

<b>Housing</b>	A Height	182mm / 7,17in
	B Height	175mm / 6,89in
	C Length shell	198mm / 7,8in
	D Length w. cover	238mm / 9,37in
	E Width	160mm / 6,3in

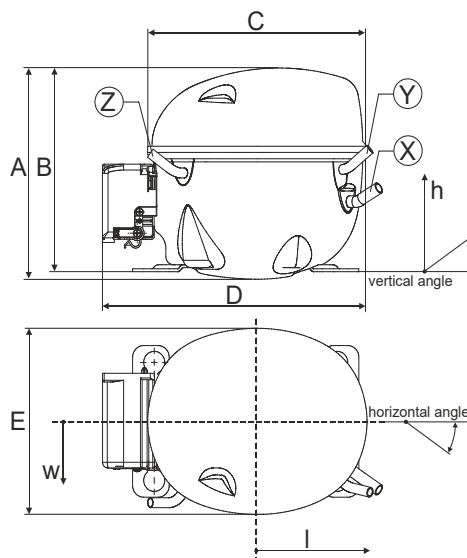

Connectors		Suction	Discharge	Process
		X	Y	Z
Diameter	[mm]	øi 8,11-8,29	øi 6,41-6,59	øi 6,41-6,59
(i:inside, o:outside)	[in]	øi 0,32-0,33	øi 0,25-0,26	øi 0,25-0,26
Material		copper	copper	copper
Horizontal angle	±2°	35°	13°	0°
Vertical angle	±2°	30°	40°	145°
Position l/h/w	[mm]	119/73/59	117/107/66	-88/101/71
	[in]	4,7/2,9/2,3	4,6/4,2/2,6	-3,5/4/2,8
Straight tube l.	[mm]	14	14	14
	[in]	0,5	0,5	0,5

## Compressor fixation

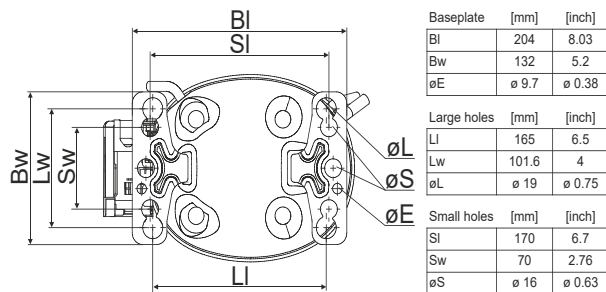

### Bolt joint



### Snap-on

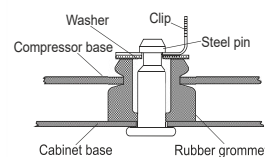

Mounting accessories	one comp.	multi pack
Bolt joint   M6   ø16mm	118-1917	118-1918
Bolt joint   ø1/4"   ø16mm	118-1946	
Bolt joint   ø1/4"   ø19mm	118-1949	
Snap-on   ø7,3   ø16mm	118-1947	118-1919

## Application notes

Provision for PE Grounding is located at the PE Stamp on the compressor

Suctiongas connector and Process connector can be switched (minor loss of cooling capacity)

## Model

Designation	<b>KLE4.8GFTX</b>	<b>220-240V/50Hz</b>	<b>Conf. 1</b>	Sales code:	<b>106G5503</b>
-------------	-------------------	----------------------	----------------	-------------	-----------------

## Configuration

Motorconfiguration	CSIR
Power supply (nominal)	220-240V/50Hz 1~
Refrigerant	R134a
Application	LBP+MBP+HBP
Voltage range	187-254V
Starting torque	HST
Approvals	VDE (UL,CB) in progress

## Electrical accessories / wiring diagram

**CSIR**

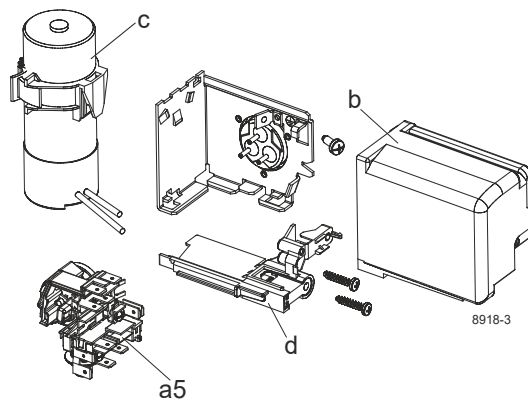

## Ambient/ machine room temperatures minimum /maximum

Ambient temperature range: 10 - 43°C / 50 - 110°F

Machine room temperature range: 10 - 48°C / 50 - 119°F

Compressor cooling: fan 3m/s

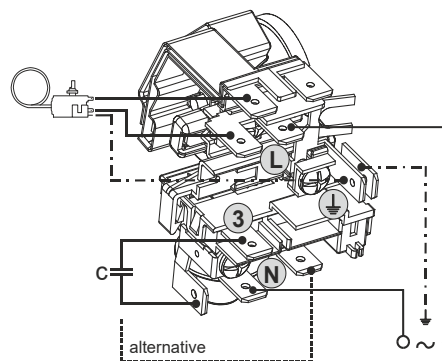

## Operation pressure range

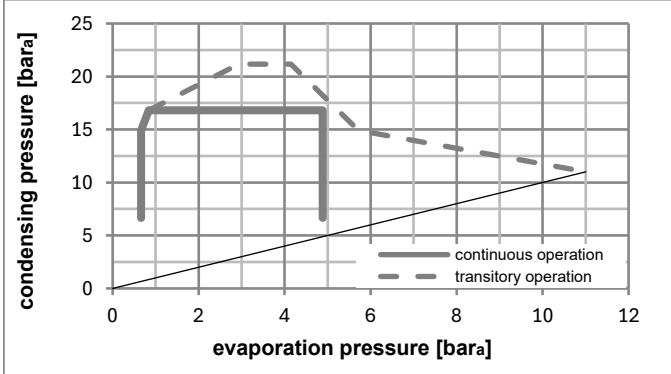
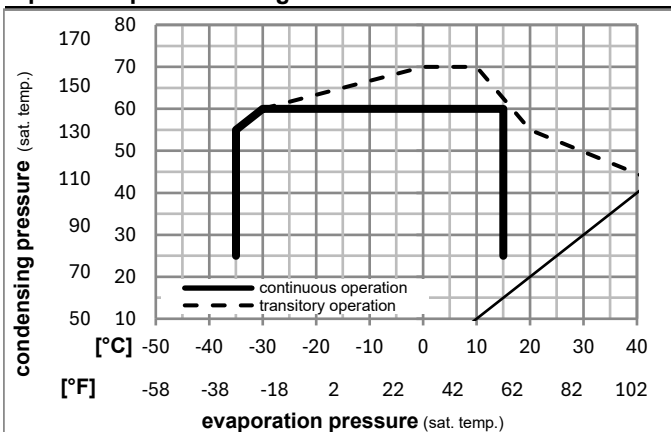

## Components

a5	current relay (T1189/L6-S3)	117U7073
c	start capacitor (80µF, 6.3mm)	117U5001
b, d	cover + clamp + screws(5VA) in bag	103N1060

## Alternative components

b, d	100x cover + clamp + screws(5VA)	103N2060
b, d	cover + clamp + screws(5VA-compl.)	103N0600

## Model

Designation **KLE4.8GFTX 220-240V/50Hz** Conf. 1 Sales code: **106G5503**

## Optimization + standard conditions

R134a, 220V/50Hz, CSIR, fan 3m/s, VDE, (UL,CB) in progress

	Evaporating pressure (saturation temperature)				Condensing pressure (saturation temperature)			Return gas temp.			Liquid temp.			Cooling capacity			COP	EER	Power consumption		
	pe	pc	RGT	Tliq	[W]	[Btu/h]	[kcal/h]	[W/W]	[Btu/Wh]	[kcal/Wh]	P1	I	m	[W]	[A]	[kg/h]					
[°C]	-23	54	32	32	129,7	443	111,6	1,26	4,31	1,09	102,8	1,18	2,52								
[°F]	-10	130	90	90																	ASHRAE LBP
[°C]	-7	54	35	46	279,9	956	240,9	1,88	6,42	1,62	148,9	1,29	6,11								ASHRAE MBP
[°F]	20	130	95	115																	
[°C]	7,2	54	35	46	502,3	1715	432,3	2,71	9,26	2,33	185,2	1,41	11,14								ASHRAE HBP
[°F]	45	130	95	115																	
[°C]	-35	40	20	40	64,4	220	55,4	0,88	3,01	0,76	73,0	1,12	1,41								EN12900 LBP
[°F]	-31	104	68	104																	
[°C]	-10	45	20	45	241,7	825	208,0	1,87	6,38	1,61	129,3	1,24	5,66								EN12900 MBP
[°F]	14	113	68	113																	
[°C]	5	50	20	50	428,2	1462	368,5	2,49	8,51	2,15	171,8	1,36	10,79								EN12900 HBP
[°F]	41	122	68	122																	

## Performance tables

R134a, 220V/50Hz, CSIR, fan 3m/s, VDE, (UL,CB) in progress

	pe		Cooling capacity			COP	EER	P1	I	m	
	[°C]	[°F]	[W]	[Btu/h]	[kcal/h]	[W/W]	[Btu/Wh]	[kcal/Wh]	[W]	[A]	[kg/h]
[°C / °F]	-35	-31	60,4	206	52,0	0,83	2,85	0,72	72,4	1,12	1,30
cond. pressure	-25	-13	111,8	382	96,2	1,17	4,00	1,01	95,5	1,17	2,42
pc= 45/113	-15	5	195,3	667	168,1	1,65	5,65	1,42	118,1	1,22	4,26
return gas temp.	-10	14	250,7	856	215,8	1,94	6,62	1,67	129,3	1,24	5,49
RGT= 32/90	0	32	392,4	1340	337,7	2,59	8,83	2,23	151,7	1,30	8,68
liquid temp	5	41	479,9	1639	413,0	2,95	10,06	2,53	163,0	1,33	10,69
Tliq= 45/113	15	59	691,7	2362	595,3	3,72	12,72	3,20	185,8	1,41	15,67
[°C / °F]	-35	-31	48,8	167	42,0	0,72	2,46	0,62	67,8	1,11	1,16
cond. pressure	-25	-13	94,7	324	81,5	0,97	3,30	0,83	97,9	1,17	2,27
pc= 55/131	-15	5	167,6	572	144,3	1,32	4,52	1,14	126,6	1,24	4,04
return gas temp	-10	14	215,8	737	185,7	1,54	5,25	1,32	140,4	1,27	5,22
RGT= 32/90	0	32	339,1	1158	291,8	2,03	6,92	1,74	167,3	1,35	8,29
liquid temp	5	41	415,5	1419	357,6	2,30	7,87	1,98	180,4	1,39	10,24
Tliq= 55/131	15	59	601,1	2053	517,3	2,92	9,96	2,51	206,1	1,49	15,10

## Model

Designation	<b>KLE4.8GFTX</b>	<b>208-230V/60Hz</b>	<b>Conf. 2</b>	Sales code:	<b>106G5503</b>
-------------	-------------------	----------------------	----------------	-------------	-----------------

## Configuration

Motorconfiguration	CSIR
Power supply (nominal)	208-230V/60Hz 1~
Refrigerant	R134a
Application	LBP+MBP
Voltage range	198-253V
Starting torque	HST
Approvals	VDE (UL,CB) in progress

## Electrical accessories / wiring diagram

CSIR

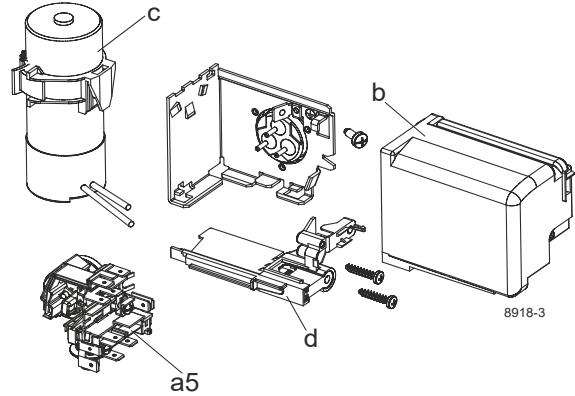

## Ambient/ machine room temperatures minimum /maximum

Ambient temperature range:	10 - 43°C / 50 - 110°F
Machine room temperature range:	10 - 48°C / 50 - 119°F
Compressor cooling:	fan 3m/s

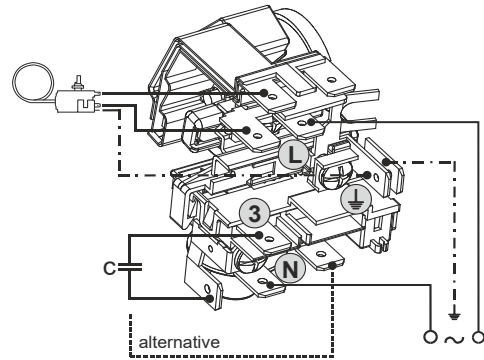

## Operation pressure range

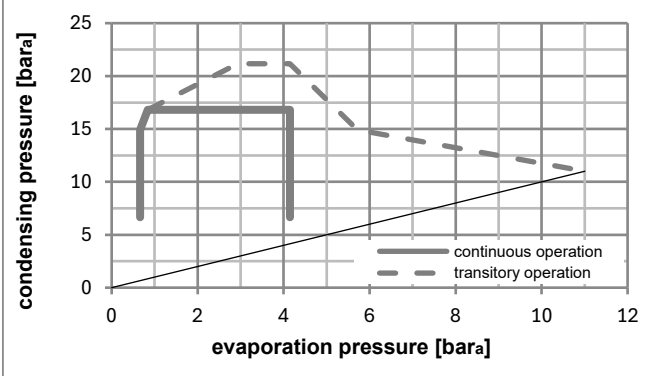
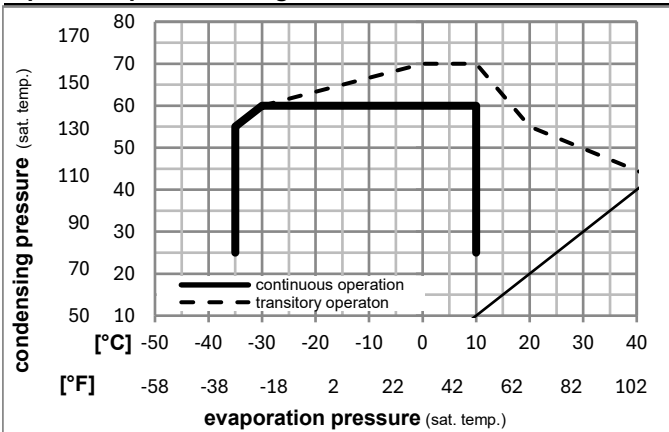

## Components

a5	current relay (T1189/L6-S3)	117U7073
c	start capacitor (80µF, 6.3mm)	117U5001
b, d	cover + clamp + screws(5VA) in bag	103N1060

## Alternative components

b, d	100x cover + clamp + screws(5VA)	103N2060
b, d	cover + clamp + screws(5VA-compl.)	103N0600

### Model

Designation **KLE4.8GFTX** **208-230V/60Hz** Conf. 2 Sales code: **106G5503**

### Optimization + standard conditions

R134a, 230V/60Hz, CSIR, fan 3m/s, VDE, (UL,CB) in progress

	Evaporating pressure (saturation temperature)				Cooling capacity			COP	EER	P1	Power consumption		Ref. mass flow	
	pe	pc	RGT	Tliq	[W]	[Btu/h]	[kcal/h]				I	m		
	[°C]	[°F]	[°C]	[°F]	[W]	[Btu/h]	[kcal/h]	[W/W]	[Btu/Wh]	[kcal/Wh]	[W]	[A]	[kg/h]	
	-23	54	32	32	154,4	527	132,9	1,30	4,44	1,12	118,6	1,13	3,00	ASHRAE LBP
	-10	130	90	90										
	-7	54	35	46	330,5	1129	284,4	1,92	6,55	1,65	172,2	1,26	7,21	ASHRAE MBP
	20	130	95	115										
	7,2	54	35	46	587,3	2006	505,4	2,71	9,25	2,33	216,9	1,39	13,03	ASHRAE HBP
	45	130	95	115										
	-35	40	20	40	81,6	279	70,2	0,94	3,22	0,81	86,7	1,08	1,79	EN12900 LBP
	-31	104	68	104										
	-10	45	20	45	281,8	963	242,6	1,87	6,39	1,61	150,6	1,20	6,60	EN12900 MBP
	14	113	68	113										
	5	50	20	50	500,8	1710	431,0	2,45	8,37	2,11	204,3	1,35	12,62	EN12900 HBP
	41	122	68	122										

### Performance tables

R134a, 230V/60Hz, CSIR, fan 3m/s, VDE, (UL,CB) in progress

	pe		Cooling capacity			COP	EER	P1	I	m	
	[°C]	[°F]	[W]	[Btu/h]	[kcal/h]						
[°C / °F]	-35	-31	76,1	260	65,5	0,89	3,05	0,77	85,3	1,07	1,64
cond. pressure	-25	-13	131,2	448	112,9	1,21	4,13	1,04	108,4	1,11	2,84
pc= 45/113	-15	5	227,5	777	195,8	1,68	5,72	1,44	135,8	1,17	4,96
return gas temp.	-10	14	292,4	999	251,6	1,94	6,63	1,67	150,6	1,20	6,40
RGT= 32/90	0	32	458,1	1565	394,3	2,53	8,64	2,18	181,0	1,28	10,13
liquid temp	5	41	560,0	1912	481,9	2,85	9,75	2,46	196,2	1,33	12,47
Tliq= 45/113	15	59	804,3	2747	692,2	3,57	12,20	3,07	225,2	1,42	18,22
[°C / °F]	-35	-31	61,0	208	52,5	0,71	2,43	0,61	85,9	1,08	1,45
cond. pressure	-25	-13	113,1	386	97,4	0,99	3,39	0,85	114,1	1,12	2,71
pc= 55/131	-15	5	198,8	679	171,1	1,37	4,66	1,18	145,5	1,19	4,78
return gas temp	-10	14	255,4	872	219,8	1,58	5,39	1,36	161,9	1,23	6,18
RGT= 32/90	0	32	398,9	1362	343,3	2,05	7,00	1,76	194,7	1,32	9,76
liquid temp	5	41	486,8	1662	418,9	2,31	7,89	1,99	210,7	1,37	12,00
Tliq= 55/131	15	59	697,4	2382	600,2	2,90	9,90	2,50	240,5	1,48	17,52



# KL Compressors

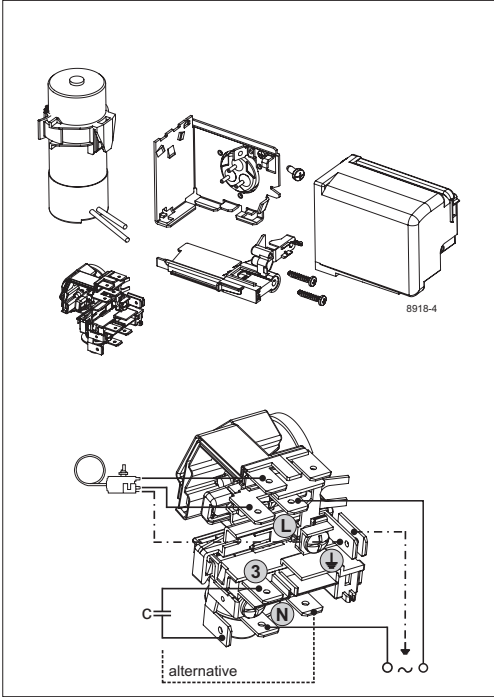
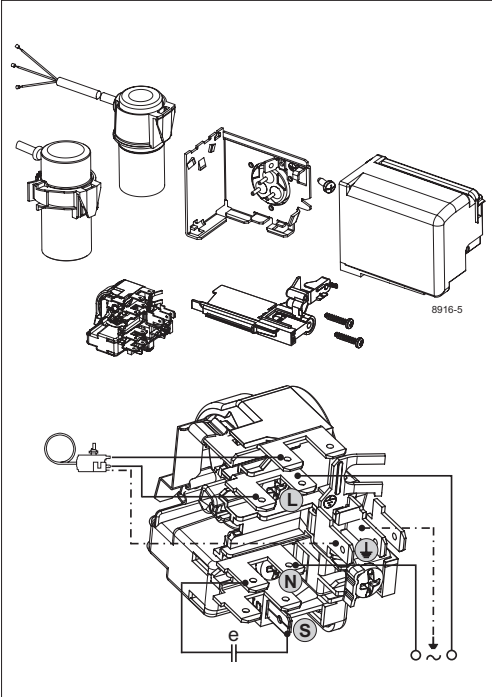
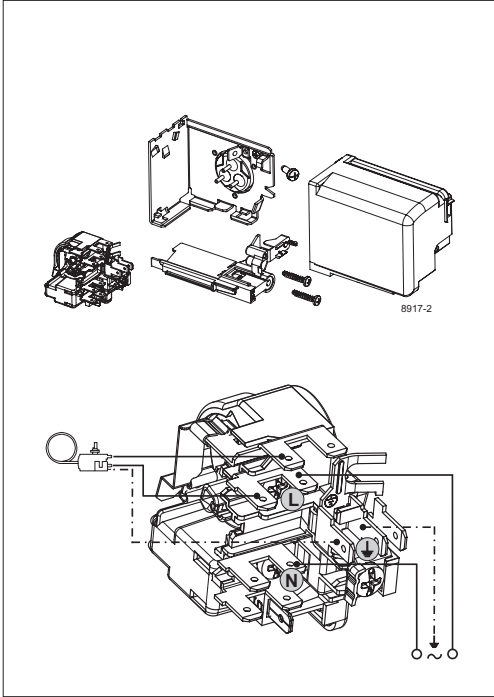



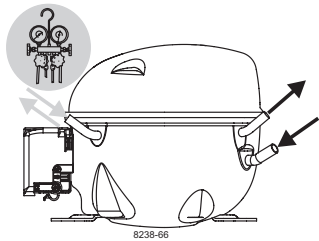

# KL Compressors



## Service/Repair – R290

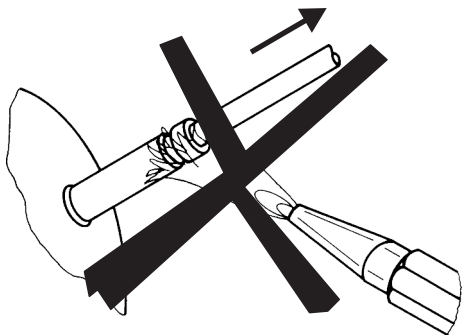

8545

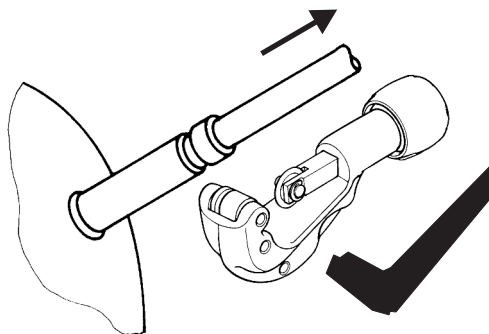

Secop accepts no responsibility for possible errors in catalogs, brochures, and other printed material. Secop reserves the right to alter its products without notice. This also applies to products already on order provided that such alterations can be made without subsequent changes being necessary to specifications already agreed. All trademarks in this material are the property of the respective companies. Secop and the Secop logotype are trademarks of Secop GmbH. All rights reserved. [www.secop.com](http://www.secop.com)