

Single Pack KLE6.6GFTX 220-240V 50Hz / 208-230V 60Hz CSIR

Codice Imballo Singolo: **195B4761**

Posizione	Titolo	Codice	Quantità
1	Compressor KLE6.6GFTX	106G5703	1
2	Starting capacitor (80 μ F 220V, 6.3mm)	117U5001	1
3	Starting relay (QLZ-5.5A, overload protector T0377/L6)	117U7071	1
4	KL accessories	103N1060	1
5	Bolt joint for one compressor M6 \varnothing 16mm	118-1917	1

Secop GmbH • Lise-Meitner-Straße 29 • 24941 Flensburg, Germany • Tel: +49 46149410 • www.secop.com

Secop non si assume alcuna responsabilità per eventuali errori presenti in cataloghi, brochure e altro materiale stampato. Secop si riserva il diritto di modificare i propri prodotti senza preavviso. Ciò vale anche per i prodotti già ordinati, a condizione che tali modifiche possano essere apportate senza che siano necessarie modifiche successive alle specifiche già concordate. Tutti i marchi presenti in questo materiale sono di proprietà delle rispettive aziende. Secop e il logo Secop sono marchi di Secop GmbH. Tutti i diritti sono riservati.

Model

Designation	KLE6.6GFTX	220-240V/50Hz 1~ 208-230V/60Hz 1~	Sales code:	106G5703
-------------	-------------------	-----------------------------------	-------------	-----------------

Compressor design

Oil type	Polyolester	Refrigerant(s)	R134a, R513A
Oil viscosity	19,2cSt	Displacement	6,6cm ³ / 0,4cu.in
Oil quantity	240cm ³ / 8,1fl.oz	Compressors on pallet	100
Refr. charge - tech. limit	250g / 8,8oz		
Free gas volume comp.	1510cm ³ / 51,1fl.oz		
Weight	9,5kg / 20,9lbs		
Motor protection	external		
Winding resistance main	8,4Ω (at 25°C)		
Winding resistance aux	11,9Ω (at 25°C)		
Max. winding temp.	125°C / 257°F		
Max. discharge temp.	130°C / 266°F		
Additional note	Good robustness against liquid intake. Ice-cube maker optimization - indirect suction intake.		



General - Configurations with KLE6.6GFTX

	Conf. 1	Conf. 2
Motorconfiguration	CSIR	CSIR
Power supply (nominal)	220-240V/50Hz	208-230V/60Hz
Number of phases	1	1
Voltage range	187-254V	198-253V
Approvals	VDE, (UL,CB) in progress	VDE, (UL,CB) in progress
Starting torque	HST	HST
Note	- / -	

Applications with KLE6.6GFTX

	Conf. 1	Conf. 2
Refrigerant	R134a	R134a
Application	LBP+MBP+HBP	LBP+MBP
System cooling	fan 3m/s	fan 3m/s
Hot gas defrost	OK	OK
Long interval pull down	OK	OK

Electrical data - Configurations with KLE6.6GFTX

	Conf. 1	Conf. 2
Starting device type	relay	relay
Run capacitor	-/-	-/-
Start capacitor	80μF	80μF
LRA (locked rotor amps / 4s/ U(N))	13,5A	13,5A
RLA (rated load amps / 1s/ U(N))	2,1A	2,1A
Cut in current (U(N))	12,3A	12,3A

Model

Designation **KLE6.6GFTX** 220-240V/50Hz 1~ 208-230V/60Hz 1~ Sales code: **106G5703**

Compressor dimensions

Housing	A Height	182mm / 7,17in
	B Height	175mm / 6,89in
	C Length shell	198mm / 7,8in
	D Length w. cover	238mm / 9,37in
	E Width	160mm / 6,3in

Connectors		Suction	Discharge	Process
		X	Y	Z
Diameter	[mm]	øi 8,11-8,29	øi 6,11-6,29	øi 6,11-6,29
(i:inside, o:outside)	[in]	øi 0,32-0,33	øi 0,24-0,25	øi 0,24-0,25
Material		copper	copper	copper
Horizontal angle	±2°	35°	13°	0°
Vertical angle	±2°	30°	40°	145°
Position l/h/w	[mm]	119/73/59	117/107/66	-88/101/71
	[in]	4,7/2,9/2,3	4,6/4,2/2,6	-3,5/4/2,8
Straight tube l.	[mm]	14	14	14
	[in]	0,5	0,5	0,5

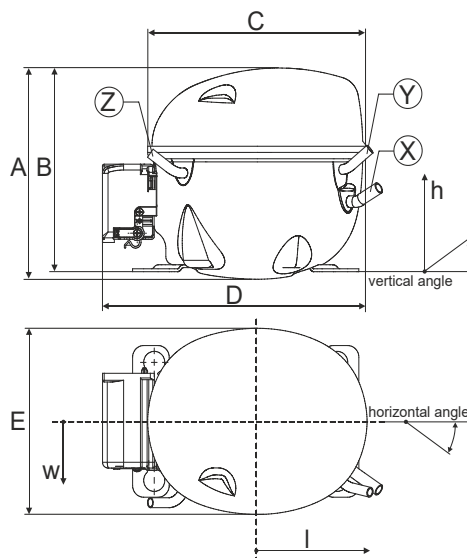

Compressor fixation



Bolt joint

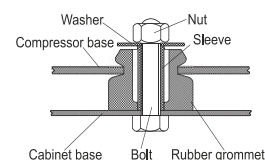

Snap-on

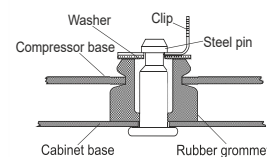

Mounting accessories	one comp.	multi pack
Bolt joint M6 ø16mm	118-1917	118-1918
Bolt joint ø1/4" ø16mm	118-1946	
Bolt joint ø1/4" ø19mm	118-1949	
Snap-on ø7,3 ø16mm	118-1947	118-1919

Application notes

Provision for PE Grounding is located at the PE Stamp on the compressor

Suctiongas connector and Process connector can be switched (minor loss of cooling capacity)

Model

Designation	KLE6.6GFTX	220-240V/50Hz	Conf. 1	Sales code:	106G5703
-------------	-------------------	----------------------	---------	-------------	-----------------

Configuration

Motorconfiguration	CSIR
Power supply (nominal)	220-240V/50Hz 1~
Refrigerant	R134a
Application	LBP+MBP+HBP
Voltage range	187-254V
Starting torque	HST
Approvals	VDE (UL,CB) in progress

Electrical accessories / wiring diagram

CSIR

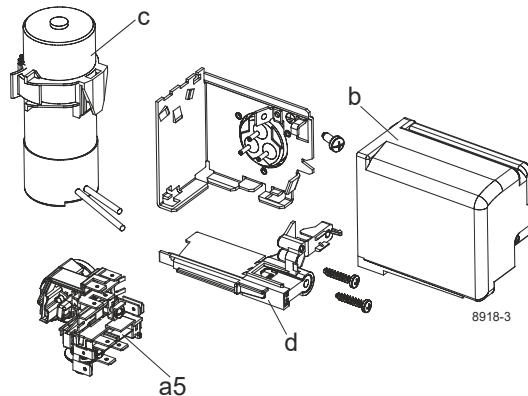

Ambient/ machine room temperatures minimum /maximum

Ambient temperature range:	10 - 43°C / 50 - 110°F
Machine room temperature range:	10 - 48°C / 50 - 119°F
Compressor cooling:	fan 3m/s

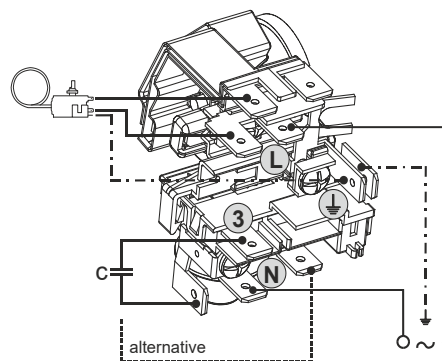

Operation pressure range

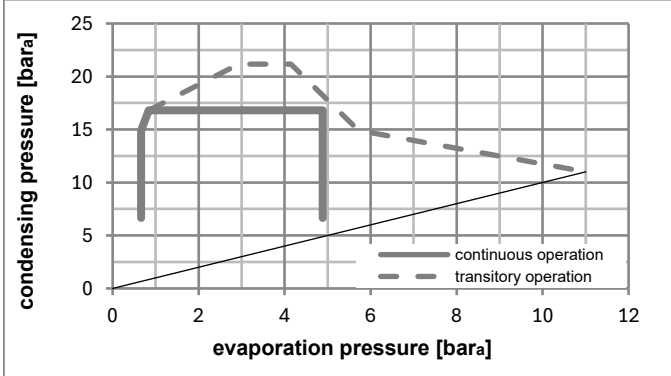
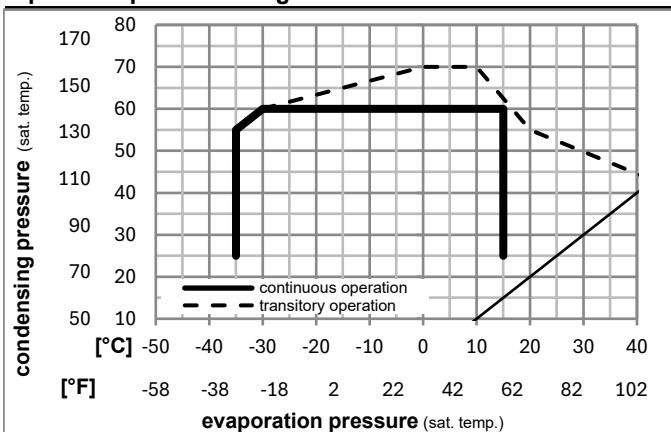

Components

a5	current relay (T0377/L6-S1)	117U7071
c	start capacitor (80µF, 6.3mm)	117U5001
b, d	cover + clamp + screws(5VA) in bag	103N1060

Alternative components

b, d	100x cover + clamp + screws(5VA)	103N2060
b, d	cover + clamp + screws(5VA-compl.)	103N0600

Model

Designation **KLE6.6GFTX 220-240V/50Hz** Conf. 1 Sales code: **106G5703**

Optimization + standard conditions

R134a, 220V/50Hz, CSIR, fan 3m/s, VDE, (UL,CB) in progress

	Evaporating pressure (saturation temperature)				Cooling capacity			COP	EER		Power consumption			ASHRAE / EN
	pe	pc	RGT	Tliq	[W]	[Btu/h]	[kcal/h]		[W/W]	[Btu/Wh]	[kcal/Wh]	P1	I	
	[°C]	[°C]	[°C]	[°C]							[W]	[A]	[kg/h]	
	-23	54	32	32	188,9	645	162,6	1,29	4,40	1,11	146,5	1,29	3,67	ASHRAE LBP
	[°F]													
	-10	130	90	90										
	-7	54	35	46	401,3	1371	345,4	1,85	6,32	1,59	216,8	1,52	8,76	ASHRAE MBP
	[°F]													
	20	130	95	115										
	7,2	54	35	46	716,7	2447	616,8	2,58	8,83	2,22	277,3	1,76	15,90	ASHRAE HBP
	[°F]													
	45	130	95	115										
	-35	40	20	40	99,4	339	85,5	0,95	3,23	0,81	105,0	1,20	2,18	EN12900 LBP
	[°F]													
	-31	104	68	104										
	-10	45	20	45	347,2	1186	298,8	1,87	6,40	1,61	185,2	1,41	8,13	EN12900 MBP
	[°F]													
	14	113	68	113										
	5	50	20	50	611,9	2090	526,6	2,40	8,20	2,07	254,9	1,67	15,42	EN12900 HBP
	[°F]													
	41	122	68	122										

Performance tables

R134a, 220V/50Hz, CSIR, fan 3m/s, VDE, (UL,CB) in progress

	pe		Cooling capacity			COP	EER		P1	I	m
	[°C]	[°F]	[W]	[Btu/h]	[kcal/h]		[W/W]	[Btu/Wh]			
[°C / °F]	-35	-31	93,8	320	80,7	0,88	3,02	0,76	106,0	1,20	2,02
cond. pressure	-25	-13	163,5	558	140,7	1,22	4,15	1,05	134,6	1,25	3,54
pc= 45/113	-15	5	281,3	961	242,1	1,68	5,73	1,44	167,5	1,35	6,13
return gas temp.	-10	14	360,2	1230	310,0	1,94	6,64	1,67	185,2	1,41	7,88
RGT= 32/90	0	32	562,0	1919	483,6	2,53	8,65	2,18	221,8	1,54	12,43
liquid temp	5	41	686,5	2344	590,8	2,86	9,76	2,46	240,3	1,61	15,28
Tliq= 45/113	15	59	986,7	3370	849,2	3,56	12,17	3,07	276,9	1,76	22,35
[°C / °F]	-35	-31	75,9	259	65,3	0,74	2,54	0,64	102,0	1,18	1,81
cond. pressure	-25	-13	138,6	473	119,3	0,99	3,38	0,85	139,9	1,27	3,31
pc= 55/131	-15	5	241,4	824	207,8	1,33	4,54	1,14	181,5	1,40	5,81
return gas temp	-10	14	309,9	1058	266,7	1,53	5,21	1,31	203,2	1,47	7,49
RGT= 32/90	0	32	485,0	1656	417,4	1,96	6,70	1,69	247,2	1,64	11,86
liquid temp	5	41	593,2	2026	510,5	2,20	7,52	1,90	269,3	1,73	14,62
Tliq= 55/131	15	59	855,0	2920	735,8	2,74	9,35	2,36	312,3	1,92	21,48

Model

Designation	KLE6.6GFTX	208-230V/60Hz	Conf. 2	Sales code:	106G5703
-------------	-------------------	----------------------	----------------	-------------	-----------------

Configuration

Motorconfiguration	CSIR
Power supply (nominal)	208-230V/60Hz 1~
Refrigerant	R134a
Application	LBP+MBP
Voltage range	198-253V
Starting torque	HST
Approvals	VDE (UL,CB) in progress

Electrical accessories / wiring diagram

CSIR

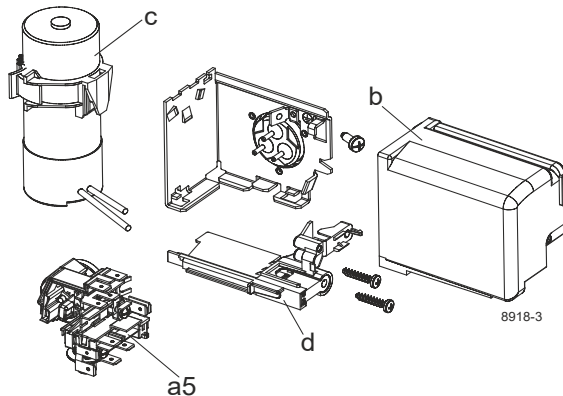

Ambient/ machine room temperatures minimum /maximum

Ambient temperature range:	10 - 43°C / 50 - 110°F
Machine room temperature range:	10 - 48°C / 50 - 119°F
Compressor cooling:	fan 3m/s

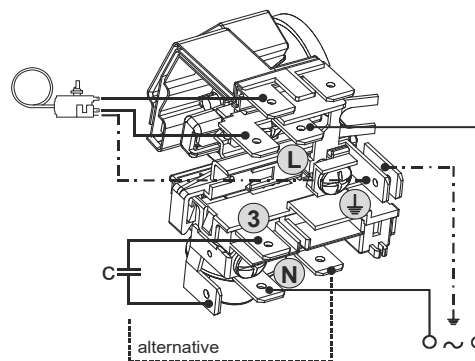

Operation pressure range

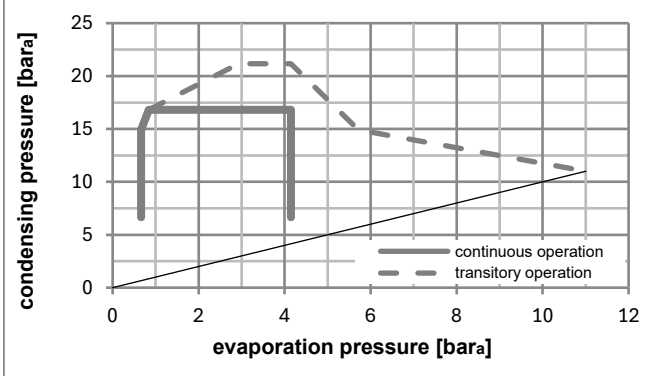
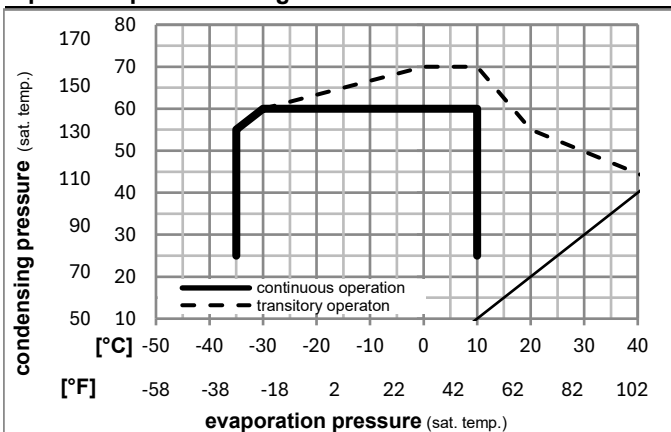

Components

a5	current relay (T0377/L6-S1)	117U7071
c	start capacitor (80µF, 6.3mm)	117U5001
b, d	cover + clamp + screws(5VA) in bag	103N1060

Alternative components

b, d	100x cover + clamp + screws(5VA)	103N2060
b, d	cover + clamp + screws(5VA-compl.)	103N0600

Model

Designation **KLE6.6GFTX** **208-230V/60Hz** Conf. 2 Sales code: **106G5703**

Optimization + standard conditions

R134a, 230V/60Hz, CSIR, fan 3m/s, VDE, (UL,CB) in progress

	Evaporating pressure (saturation temperature)				Cooling capacity			COP	EER			Power consumption			ASHRAE / EN
	pe	pc	RGT	Tliq	[W]	[Btu/h]	[kcal/h]		[W/W]	[Btu/Wh]	[kcal/Wh]	P1	I	m	
	[°C]	[°C]	[°C]	[°C]							[W]	[A]	[kg/h]		
	-23	54	32	32	228,9	782	197,0	1,37	4,68	1,18	166,9	1,25	4,45	ASHRAE LBP	
	[°F]														
	-10	130	90	90											
	[°C]	-7	54	35	46	474,6	1621	408,5	1,91	6,53	1,64	248,3	1,50	10,35	ASHRAE MBP
	[°F]	20	130	95	115										
	[°C]	7,2	54	35	46	839,2	2866	722,3	2,63	8,97	2,26	319,5	1,75	18,62	ASHRAE HBP
	[°F]	45	130	95	115										
	[°C]	-35	40	20	40	118,4	404	101,9	1,09	3,72	0,94	108,7	1,11	2,60	EN12900 LBP
	[°F]	-31	104	68	104										
	[°C]	-10	45	20	45	407,9	1393	351,0	1,88	6,43	1,62	216,5	1,39	9,55	EN12900 MBP
	[°F]	14	113	68	113										
	[°C]	5	50	20	50	715,2	2443	615,5	2,40	8,21	2,07	297,6	1,67	18,02	EN12900 HBP
	[°F]	41	122	68	122										

Performance tables

R134a, 230V/60Hz, CSIR, fan 3m/s, VDE, (UL,CB) in progress

	pe		Cooling capacity			COP	EER		P1	I	m
	[°C]	[°F]	[W]	[Btu/h]	[kcal/h]		[W/W]	[Btu/Wh]			
[°C / °F]	-35	-31	111,4	380	95,9	1,04	3,54	0,89	107,6	1,11	2,40
cond. pressure	-25	-13	196,8	672	169,4	1,29	4,39	1,11	153,1	1,21	4,26
pc= 45/113	-15	5	332,8	1137	286,4	1,70	5,81	1,47	195,5	1,32	7,25
return gas temp.	-10	14	423,2	1445	364,2	1,95	6,67	1,68	216,5	1,39	9,26
RGT= 32/90	0	32	655,6	2239	564,2	2,52	8,60	2,17	260,5	1,54	14,50
liquid temp	5	41	800,4	2733	688,8	2,82	9,62	2,42	284,1	1,62	17,82
Tliq= 45/113	15	59	1154,0	3941	993,2	3,43	11,70	2,95	336,9	1,81	26,14
[°C / °F]	-35	-31	86,1	294	74,1	0,82	2,80	0,71	105,0	1,10	2,05
cond. pressure	-25	-13	167,9	573	144,5	1,06	3,61	0,91	158,9	1,22	4,02
pc= 55/131	-15	5	289,4	988	249,0	1,39	4,74	1,19	208,6	1,37	6,97
return gas temp	-10	14	368,4	1258	317,1	1,58	5,40	1,36	233,0	1,44	8,91
RGT= 32/90	0	32	570,0	1947	490,6	2,02	6,89	1,74	282,6	1,62	13,94
liquid temp	5	41	695,3	2375	598,4	2,25	7,69	1,94	308,7	1,71	17,13
Tliq= 55/131	15	59	1001,8	3421	862,1	2,74	9,36	2,36	365,7	1,93	25,16



KL Compressors



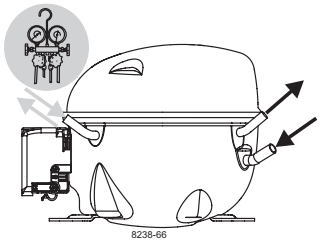

KL Compressors



Service/Repair – R290

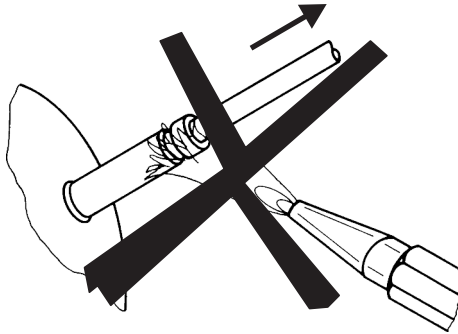

8545

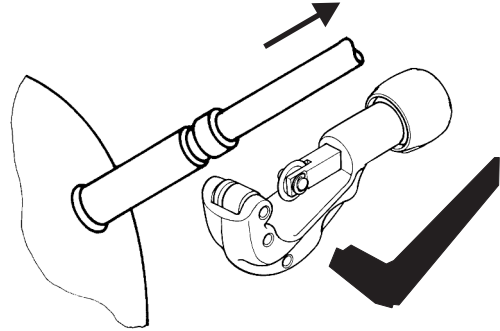

Secop accepts no responsibility for possible errors in catalogs, brochures, and other printed material. Secop reserves the right to alter its products without notice. This also applies to products already on order provided that such alterations can be made without subsequent changes being necessary to specifications already agreed. All trademarks in this material are the property of the respective companies. Secop and the Secop logotype are trademarks of Secop GmbH. All rights reserved. www.secop.com