

Single Pack SC21MFX 220-240V 50Hz CSIR

Codice Imballo Singolo: **195B4765**

Posizione	Titolo	Codice	Quantità
1	Compressor SC21MFX	104G8120	1
2	Starting relay	117U6019	1
3	Starting capacitor (80 μ F 220V, 6.3mm)	117U5017	1
4	Cord relief	103N1004	1
5	Cover	103N2009	1
6	Bolt joint for one compressor M6 \varnothing 16mm	118-1917	1

Secop GmbH • Lise-Meitner-Straße 29 • 24941 Flensburg, Germany • Tel: +49 46149410 • www.secop.com

Secop non si assume alcuna responsabilità per eventuali errori presenti in cataloghi, brochure e altro materiale stampato. Secop si riserva il diritto di modificare i propri prodotti senza preavviso. Ciò vale anche per i prodotti già ordinati, a condizione che tali modifiche possano essere apportate senza che siano necessarie modifiche successive alle specifiche già concordate. Tutti i marchi presenti in questo materiale sono di proprietà delle rispettive aziende. Secop e il logo Secop sono marchi di Secop GmbH. Tutti i diritti sono riservati.

Model

Designation	SC21MFX	220-240V/50Hz 1~	Sales code:	104G8120
-------------	----------------	------------------	-------------	-----------------

Compressor design

Oil type	Polyolester	Refrigerant(s)	R134a, R513A
Oil viscosity	22cST	Displacement	20,95cm ³ / 1,28cu.in
Oil quantity	550cm ³ / 18,6fl.oz	Compressors on pallet	80
Refr. charge - tech. limit	1300g / 45,9oz		
Free gas volume comp.	1460cm ³ / 49,4fl.oz		
Weight	13,7kg / 30,2lbs		
Motor protection	1# internal		
Winding resistance main	3,4Ω (at 25°C)		
Winding resistance aux	14,4Ω (at 25°C)		
Max. winding temp.	125°C / 257°F		
Max. discharge temp.	130°C / 266°F		



General - Configurations with SC21MFX

	Conf. 1	Conf. 2	Conf. 3
Motorconfiguration	CSIR	CSCR	CSIR
Power supply (nominal)	220-240V/50Hz	220-240V/50Hz	220-240V/50Hz
Number of phases	1	1	1
Voltage range	187-254V	187-254V	187-254V
Approvals	VDE, CCC, EAC	VDE, CCC, EAC	VDE, CCC, EAC
Starting torque	HST	HST	HST
Note	- / -		

Applications with SC21MFX

	Conf. 1	Conf. 2	Conf. 3
Refrigerant	R134a	R134a	R513A
Application	MBP	MBP	MBP
System cooling	fan 3m/s	fan 3m/s	fan 3m/s
Hot gas defrost	OK	OK	OK
Long interval pull down	OK	OK	OK

Electrical data - Configurations with SC21MFX

	Conf. 1	Conf. 2	Conf. 3
Starting device type	relay	relay	relay
Run capacitor	- / -	10μF	- / -
Start capacitor	80μF	80μF	80μF
LRA (locked rotor amps / 4s)	23,4A	23,4A	23,4A
RLA (rated load amps / 1s)	4,3A	4,3A	4,3A
Cut in current	23,4A	23,4A	23,4A

Model

Designation

SC21MFX

220-240V/50Hz 1~

Sales code:

104G8120

Compressor dimensions

Housing	A Height	219mm / 8,62in
	B Height	213mm / 8,39in
	C Length shell	218mm / 8,58in
	D Length w. cover	255mm / 10,04in
	E Width	151mm / 5,94in

Connectors	Suction X	Discharge Y	Process Z
Diameter [mm]	øi 10,11-10,29	øi 6,11-6,29	øi 6,11-6,29
(i:inside, o:outside) [in]	øi 0,4-0,41	øi 0,24-0,25	øi 0,24-0,25
Material	copper	copper	copper
Horizontal angle ±2°	37°	37°	143°
Vertical angle ±2°	30°	0°	150°
Position l/h/w [mm]	107/193/55	115/110/63	-107/193/55
[in]	4,2/7,6/2,2	4,5/4,3/2,5	-4,2/7,6/2,2
Straight tube l. [mm]	12	12	12
[in]	0,5	0,5	0,5

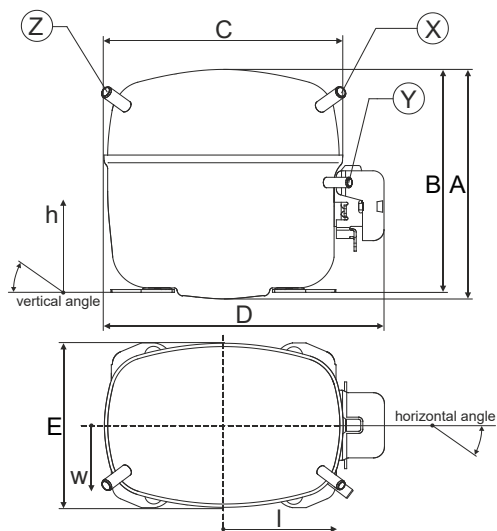

Compressor fixation



Bolt joint



Snap-on

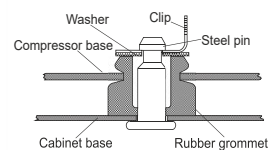

Mounting accessories

Mounting accessories	one comp.	multi pack
Bolt joint M6 ø16mm	118-1917	118-1918
Bolt joint ø1/4" ø16mm	118-1946	
Bolt joint ø1/4" ø19mm	118-1949	
Snap-on ø7,3 ø16mm	118-1947	118-1919

Application notes

Provision for PE Grounding is located at the PE Stamp on the compressor

Model

Designation	SC21MFX	220-240V/50Hz	Conf. 1	Sales code:	104G8120
-------------	----------------	----------------------	----------------	-------------	-----------------

Configuration

Motorconfiguration	CSIR
Power supply (nominal)	220-240V/50Hz 1~
Refrigerant	R134a
Application	MBP
Voltage range	187-254V
Starting torque	HST
Approvals	VDE CCC EAC

Electrical accessories / wiring diagram

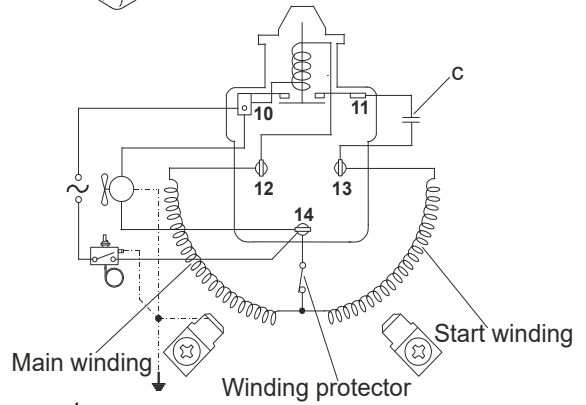
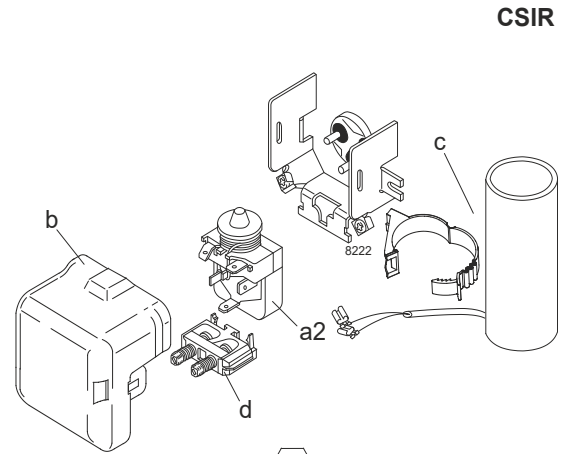

Ambient/ machine room temperatures minimum /maximum

Ambient temperature range:	10 - 43°C / 50 - 110°F
Machine room temperature range:	10 - 48°C / 50 - 119°F
Compressor cooling:	fan 3m/s

Operation Limits

Operation pressure range

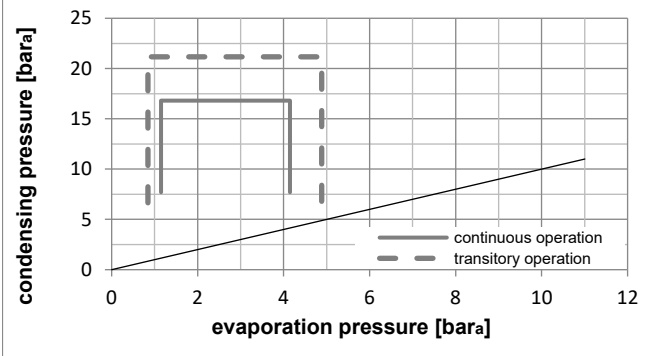
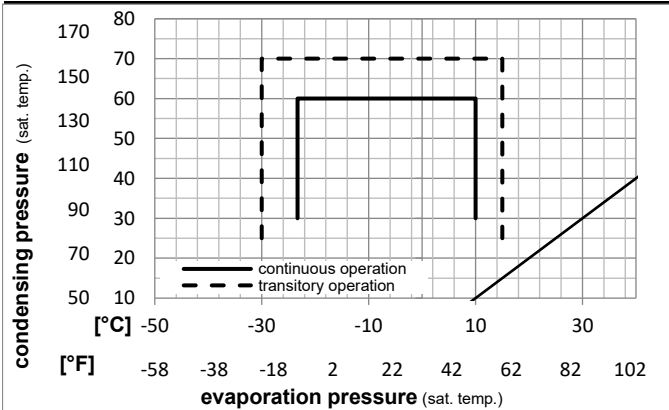

Components

a2	relay	117U6019
c	start capacitor (80μF)	117U5017
d	cord relief	103N1004
b	plastic cover	103N2009

Model

Designation **SC21MFX** **220-240V/50Hz** Conf. 1 Sales code: **104G8120**

Optimization + standard conditions

R134a, 220V/50Hz, CSIR, fan 3m/s, VDE, CCC, EAC

	pe	pc	RGT	Tliq	Cooling capacity	COP	EER	P1	I	Ref. mass flow	
	[°C]	[°C]	[°C]	[°C]	[W]	[W/W]	[Btu/Wh]	[W]	[A]	[kg/h]	
ASHRAE MBP	-7	54	35	46	1082,2	1,65	5,63	656,3	4,48	23,61	
	[°F]	[°F]	[°F]	[°F]	[Btu/h]	[kcal/h]	[kcal/Wh]	[W]	[A]	[kg/h]	
	20	130	95	115	3696	931,4	1,42	656,3	4,48	23,61	
cecomaf MBP	-10	55	32	55	840,0	1,37	4,66	615,0	4,35	20,31	
	[°F]	[°F]	[°F]	[°F]	[W]	[W/W]	[Btu/Wh]	[W]	[A]	[kg/h]	
	14	131	90	131	2869	722,9	1,18	615,0	4,35	20,31	
EN12900 MBP	-10	45	20	45	940,6	1,62	5,52	581,7	4,18	22,02	
	[°F]	[°F]	[°F]	[°F]	[W]	[W/W]	[Btu/Wh]	[W]	[A]	[kg/h]	
	14	113	68	113	3212	809,5	1,39	581,7	4,18	22,02	
ARI540 MBP	-7	49	18	49	1024,1	1,61	5,51	634,5	4,37	25,30	
	[°F]	[°F]	[°F]	[°F]	[W]	[W/W]	[Btu/Wh]	[W]	[A]	[kg/h]	
	20	120	65	120	3497	881,3	1,39	634,5	4,37	25,30	
opt	-10	45	32	45	975,9	1,68	5,73	581,7	4,18	21,36	
	[°F]	[°F]	[°F]	[°F]	[W]	[W/W]	[Btu/Wh]	[W]	[A]	[kg/h]	
	14	113	90	113	3333	839,8	1,44	581,7	4,18	21,36	
opt	-25	45	32	45	464,8	1,14	3,88	408,8	3,47	10,07	
	[°F]	[°F]	[°F]	[°F]	[W]	[W/W]	[Btu/Wh]	[W]	[A]	[kg/h]	
	-13	113	90	113	1587	400,0	0,98	408,8	3,47	10,07	

Performance tables

R134a, 220V/50Hz, CSIR, fan 3m/s, VDE, CCC, EAC

	pe	Cooling capacity			COP	EER	P1	I	m		
	[°C]	[°F]	[W]	[Btu/h]	[kcal/h]	[W/W]	[Btu/Wh]	[kcal/Wh]	[W]	[A]	[kg/h]
[°C / °F]	-23	-10	509,3	1739	438,3	1,19	4,06	1,02	428,3	3,55	11,04
cond. pressure	-20	-4	604,5	2065	520,3	1,30	4,43	1,12	466,1	3,72	13,13
pc= 45/113	-15	5	773,4	2641	665,6	1,48	5,04	1,27	523,6	3,95	16,86
return gas temp.	-10	14	975,9	3333	839,8	1,68	5,73	1,44	581,7	4,18	21,36
RGT= 32/90	0	32	1498,6	5118	1289,7	2,14	7,30	1,84	701,4	4,59	33,14
liquid temp	5	41	1827,7	6242	1572,9	2,39	8,17	2,06	763,7	4,78	40,69
Tliq= 45/113	10	50	2207,7	7540	1900,0	2,67	9,10	2,29	828,2	4,96	49,54
[°C / °F]	-23	-10	429,7	1467	369,8	0,97	3,33	0,84	441,3	3,69	10,28
cond. pressure	-20	-4	513,5	1754	441,9	1,06	3,62	0,91	484,7	3,86	12,32
pc= 55/131	-15	5	661,9	2261	569,7	1,20	4,11	1,04	550,0	4,11	15,93
return gas temp	-10	14	840,0	2869	722,9	1,37	4,66	1,18	615,0	4,35	20,31
RGT= 32/90	0	32	1302,7	4449	1121,1	1,75	5,96	1,50	746,0	4,79	31,87
liquid temp	5	41	1596,0	5451	1373,6	1,96	6,71	1,69	812,7	4,99	39,33
Tliq= 55/131	10	50	1936,4	6613	1666,5	2,20	7,51	1,89	880,8	5,18	48,14

Model

Designation	SC21MFX	220-240V/50Hz	Conf. 2	Sales code:	104G8120
-------------	----------------	----------------------	----------------	-------------	-----------------

Configuration

Motorconfiguration	CSCR
Power supply (nominal)	220-240V/50Hz 1~
Refrigerant	R134a
Application	MBP
Voltage range	187-254V
Starting torque	HST
Approvals	VDE CCC EAC

Electrical accessories / wiring diagram

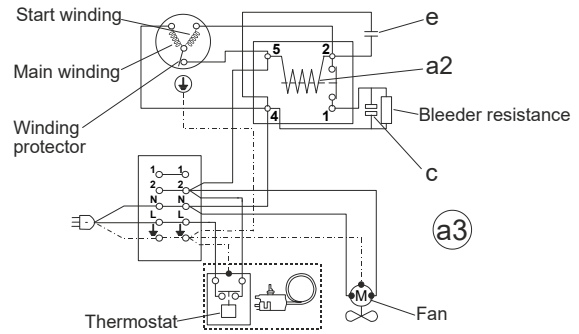
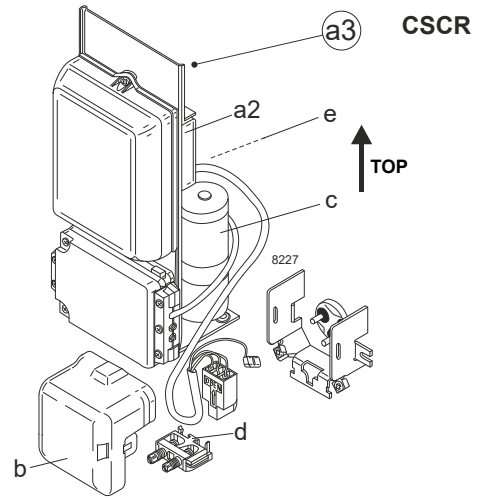

Ambient/ machine room temperatures minimum /maximum

Ambient temperature range:	10 - 43°C / 50 - 110°F
Machine room temperature range:	10 - 48°C / 50 - 119°F
Compressor cooling:	fan 3m/s

Operation Limits

Operation pressure range

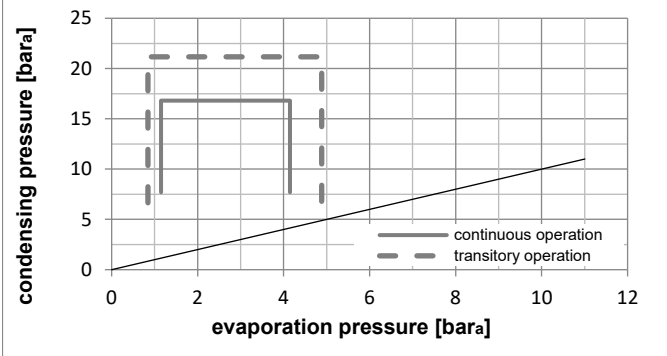
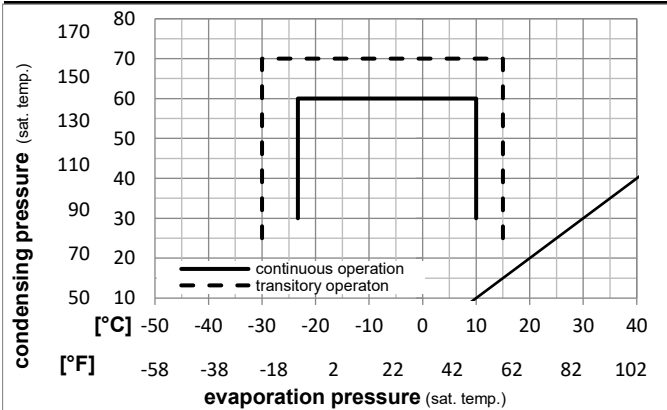

Components

a3	SC starter kit (550mm)	117-7039
b	plastic cover	103N2009
d	cord relief	103N1004

Alternative components

a3	SC starter kit (1000mm)	117-7043
----	-------------------------	----------

Model

Designation **SC21MFX** **220-240V/50Hz** Conf. 2 Sales code: **104G8120**

Optimization + standard conditions

R134a, 220V/50Hz, CSCR, fan 3m/s, VDE, CCC, EAC

		Evaporating pressure (saturation temperature)				Condensing pressure (saturation temperature)						Power consumption			
		Return gas temp.				Liquid temp.						Current consumption			Ref. mass flow
		Cooling capacity				COP	EER	P1			I	m			
		pe	pc	RGT	Tliq	[W]	[Btu/h]	[kcal/h]	[W/W]	[Btu/Wh]	[kcal/Wh]	[W]	[A]	[kg/h]	
[°C]	[°F]														
-7	20	54	35	46	1115,5	3810	960,1	1,76	6,01	1,52	633,6	3,69	24,34	ASHRAE MBP	
54	130	95	115												
-10	14	55	32	55	866,0	2957	745,2	1,46	4,98	1,25	594,0	3,52	20,94	cecomaf MBP	
55	131	90	131												
-10	14	45	20	45	969,6	3311	834,4	1,73	5,89	1,48	562,1	3,28	22,70	EN12900 MBP	
45	113	68	113												
-7	20	49	18	49	1055,5	3605	908,4	1,72	5,88	1,48	612,7	3,52	26,07	ARI540 MBP	
49	120	65	120												
-10	14	45	32	45	1005,9	3435	865,7	1,79	6,11	1,54	562,1	3,28	22,01	opt	
45	113	90	113												
-25	-13	45	32	45	479,3	1637	412,5	1,21	4,13	1,04	396,2	2,38	10,38	opt	
45	113	90	113												

Performance tables

R134a, 220V/50Hz, CSCR, fan 3m/s, VDE, CCC, EAC

	pe		Cooling capacity			COP	EER	P1			I	m
	[°C]	[°F]	[W]	[Btu/h]	[kcal/h]	[W/W]	[Btu/Wh]	[kcal/Wh]	[W]	[A]	[kg/h]	
[°C / °F]	-23	-10	525,2	1794	452,0	1,27	4,32	1,09	414,8	2,49	11,39	
cond. pressure	-20	-4	623,3	2129	536,4	1,38	4,72	1,19	451,1	2,69	13,54	
pc= 45/113	-15	5	797,3	2723	686,2	1,57	5,38	1,36	506,3	2,99	17,38	
return gas temp.	-10	14	1005,9	3435	865,7	1,79	6,11	1,54	562,1	3,28	22,01	
RGT= 32/90	0	32	1544,5	5275	1329,2	2,28	7,79	1,96	676,9	3,80	34,16	
liquid temp	5	41	1883,5	6433	1621,0	2,56	8,73	2,20	736,7	4,04	41,93	
Tliq= 45/113	10	50	2275,0	7770	1957,9	2,85	9,73	2,45	798,5	4,26	51,05	
[°C / °F]	-23	-10	443,2	1513	381,4	1,04	3,54	0,89	427,3	2,65	10,61	
cond. pressure	-20	-4	529,5	1808	455,7	1,13	3,86	0,97	468,9	2,88	12,70	
pc= 55/131	-15	5	682,4	2331	587,3	1,28	4,38	1,10	531,6	3,21	16,43	
return gas temp	-10	14	866,0	2957	745,2	1,46	4,98	1,25	594,0	3,52	20,94	
RGT= 32/90	0	32	1342,7	4585	1155,5	1,87	6,37	1,61	719,7	4,10	32,84	
liquid temp	5	41	1644,8	5617	1415,6	2,10	7,17	1,81	783,7	4,36	40,53	
Tliq= 55/131	10	50	1995,6	6815	1717,4	2,35	8,03	2,02	849,0	4,61	49,61	

Model

Designation	SC21MFX	220-240V/50Hz	Conf. 3	Sales code:	104G8120
-------------	----------------	----------------------	----------------	-------------	-----------------

Configuration

Motorconfiguration	CSIR
Power supply (nominal)	220-240V/50Hz 1~
Refrigerant	R513A
Application	MBP
Voltage range	187-254V
Starting torque	HST
Approvals	VDE CCC EAC

Electrical accessories / wiring diagram

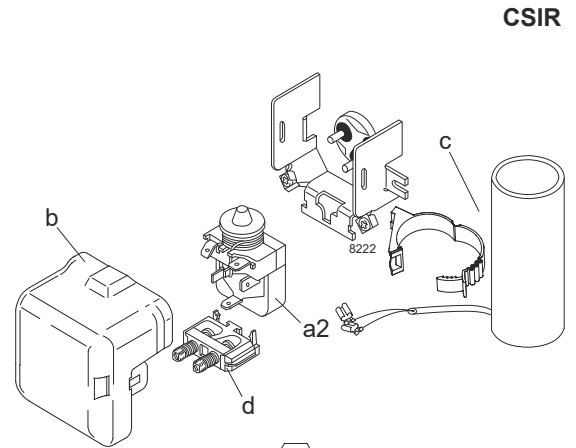

CSIR

Ambient/ machine room temperatures minimum /maximum

Ambient temperature range:	10 - 43°C / 50 - 110°F
Machine room temperature range:	10 - 48°C / 50 - 119°F
Compressor cooling:	fan 3m/s

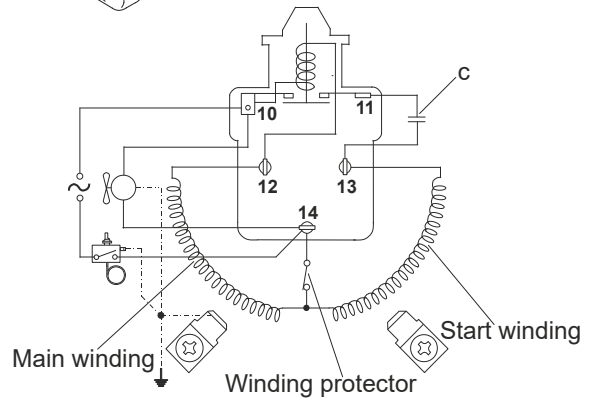

Operation Limits

Operation pressure range

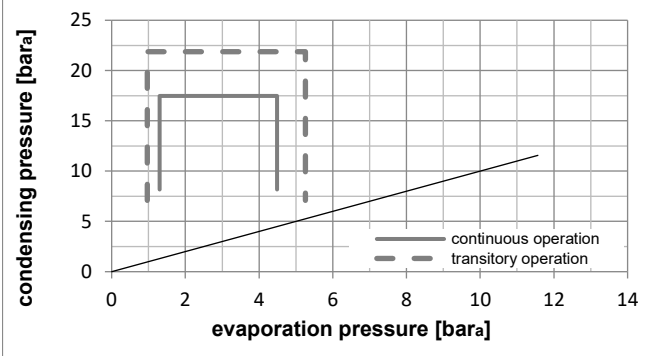
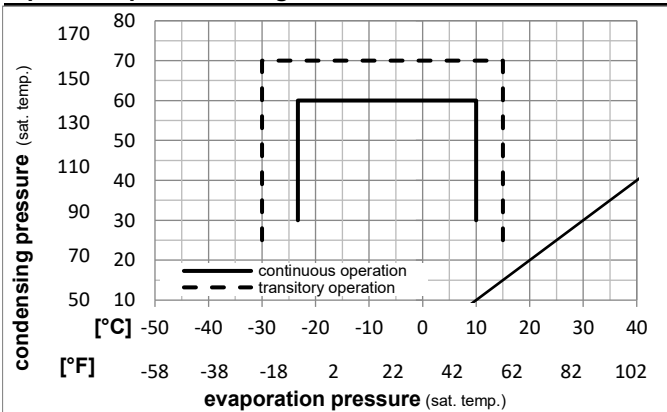

Components

a2	relay	117U6019
c	start capacitor (80μF)	117U5017
d	cord relief	103N1004
b	plastic cover	103N2009

Model

Designation **SC21MFX** **220-240V/50Hz** Conf. 3 Sales code: **104G8120**

Optimization + standard conditions

R513A, 220V/50Hz, CSIR, fan 3m/s, VDE, CCC, EAC

		Evaporating pressure (saturation temperature)				Condensing pressure (saturation temperature)						Power consumption			
		Return gas temp.				Liquid temp.						Current consumption			Ref. mass flow
		Cooling capacity				COP	EER	P1			I	m			
		pe	pc	RGT	Tliq	[W]	[Btu/h]	[kcal/h]	[W/W]	[Btu/Wh]	[kcal/Wh]	[W]	[A]	[kg/h]	
[°C]	-7	54	35	46	1131,2	3863	973,5	1,62	5,55	1,40	696,6	4,57	27,71	ASHRAE MBP	
[°F]	20	130	95	115											
[°C]	-10	55	32	55	867,3	2962	746,4	1,32	4,52	1,14	655,8	4,41	23,98	cecomaf MBP	
[°F]	14	131	90	131											
[°C]	-10	45	20	45	979,7	3346	843,1	1,58	5,40	1,36	619,9	4,28	25,97	EN12900 MBP	
[°F]	14	113	68	113											
[°C]	-7	49	18	49	1053,0	3596	906,2	1,56	5,34	1,35	673,0	4,48	29,67	ARI540 MBP	
[°F]	20	120	65	120											
[°C]	-10	45	32	45	1024,5	3499	881,7	1,65	5,64	1,42	619,9	4,28	25,19	opt	
[°F]	14	113	90	113											
[°C]	-25	45	32	45	501,7	1713	431,8	1,12	3,83	0,97	447,2	3,62	12,23	opt	
[°F]	-13	113	90	113											

Performance tables

R513A, 220V/50Hz, CSIR, fan 3m/s, VDE, CCC, EAC

	pe		Cooling capacity			COP	EER	P1			I	m
	[°C]	[°F]	[W]	[Btu/h]	[kcal/h]	[W/W]	[Btu/Wh]	[kcal/Wh]	[W]	[A]	[kg/h]	
[°C / °F]	-23	-10	547,7	1871	471,4	1,17	4,00	1,01	467,2	3,70	13,36	
cond. pressure	-20	-4	645,8	2206	555,8	1,28	4,36	1,10	505,6	3,84	15,78	
pc= 45/113	-15	5	818,8	2796	704,7	1,45	4,97	1,25	562,8	4,06	20,06	
return gas temp.	-10	14	1024,5	3499	881,7	1,65	5,64	1,42	619,9	4,28	25,19	
RGT= 32/90	0	32	1549,8	5293	1333,8	2,10	7,16	1,81	738,8	4,73	38,44	
liquid temp	5	41	1877,3	6411	1615,6	2,34	7,98	2,01	803,0	4,97	46,82	
Tliq= 45/113	10	50	2253,2	7695	1939,2	2,58	8,82	2,22	872,0	5,24	56,57	
[°C / °F]	-23	-10	455,5	1556	392,0	0,95	3,23	0,81	481,7	3,75	12,48	
cond. pressure	-20	-4	540,4	1845	465,0	1,03	3,51	0,88	525,8	3,92	14,84	
pc= 55/131	-15	5	689,6	2355	593,5	1,17	3,98	1,00	591,1	4,17	19,00	
return gas temp.	-10	14	867,3	2962	746,4	1,32	4,52	1,14	655,8	4,41	23,98	
RGT= 32/90	0	32	1323,7	4521	1139,2	1,68	5,74	1,45	787,6	4,91	36,97	
liquid temp	5	41	1610,3	5500	1385,9	1,88	6,42	1,62	857,3	5,18	45,25	
Tliq= 55/131	10	50	1941,2	6629	1670,6	2,08	7,12	1,79	931,0	5,46	54,96	

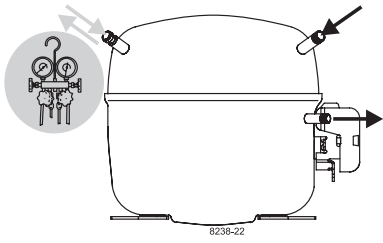

SC Compressors

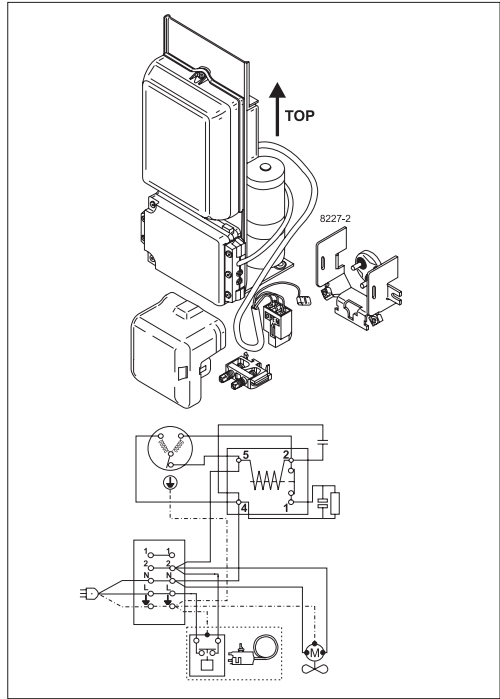
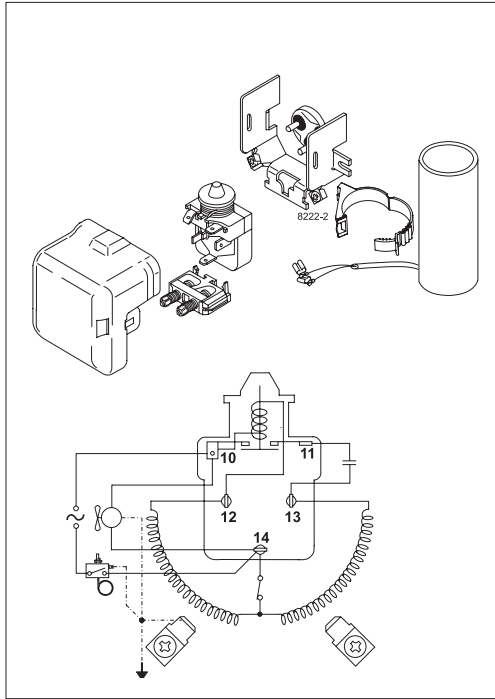
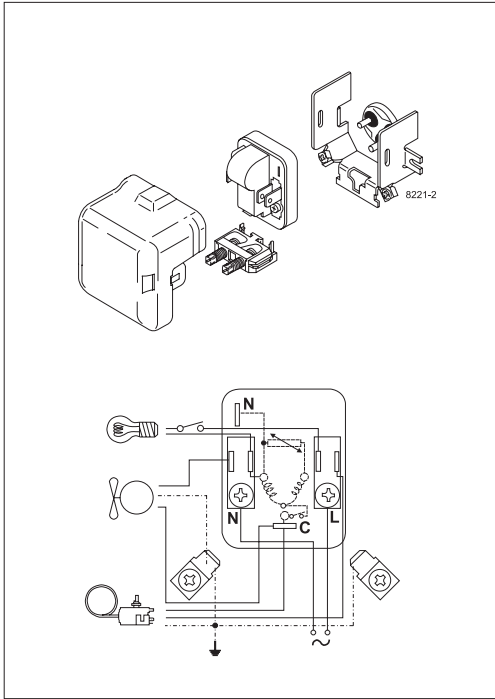

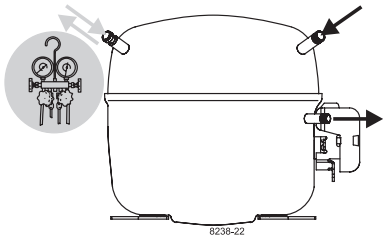

SC Compressors

Service/Repair – R290

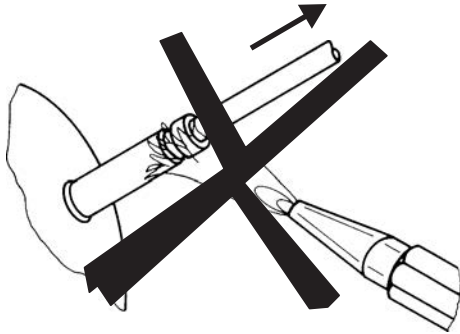

8545

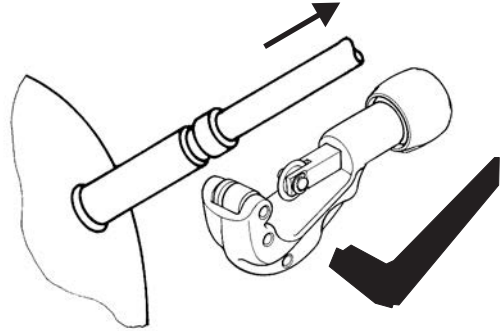

Secop accepts no responsibility for possible errors in catalogs, brochures, and other printed material. Secop reserves the right to alter its products without notice. This also applies to products already on order provided that such alterations can be made without subsequent changes being necessary to specifications already agreed. All trademarks in this material are the property of the respective companies. Secop and the Secop logotype are trademarks of Secop GmbH. All rights reserved. www.secop.com