

## Single Pack BD1.4F-VSD-HD 12/24V DC PM

Single pack code number: **195B3443**

Position	Title	Code	Amount
1	Compressor BD1.4F VSD-HD	109Z0250	1
2	Electronic unit BD	101M2131	1
3	Bolt joint for one compressor   M6   ø16mm	118-1917	1

**Secop GmbH** • Lise-Meitner-Straße 29 • 24941 Flensburg, Germany • Tel: +49 461 4941 0 • [www.secop.com](http://www.secop.com)

Secop accepts no responsibility for possible errors in catalogs, brochures, and other printed material. Secop reserves the right to alter its products without notice. This also applies to products already on order provided that such alterations can be made without subsequent changes being necessary to specifications already agreed. All trademarks in this material are the property of the respective companies. Secop and the Secop logotype are trademarks of Secop GmbH. All rights reserved.

## BD1.4F-VSD-HD Direct Current Compressor R134a, R1234yf 12/24V DC

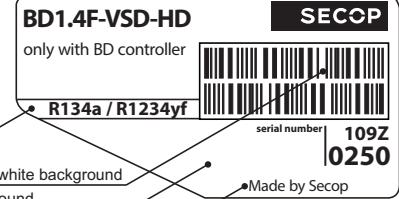

Blue stripe  
Barcode on white background  
Grey background  
Country of origin or manufacturer  
serial number 109Z0250  
Made by Secoop

### General

Code number (without electronic unit)	109Z0250
Electronic unit - Variable Speed	101N2130, 30 pcs: 101N2131
Compressors on pallet	180

### Application

Application	LBP/MBP/HBP	
Evaporating temperature	°C	-30 to 15
Voltage range	VDC	9.6 - 17 / 19 - 34
Max. condensing temperature continuous (short)	°C	60 (70)
Max. winding temperature continuous (short)	°C	125 (135)

### Cooling requirements

Application	LBP	MBP	HBP
32°C	S	S	S
38°C	S	S	S
43°C	S	S	S

Remarks on application:

**HD (Heavy Duty) version of the BD1.4F-VSD which can handle extreme vibrations.**

### Motor

Motor type	permanet magnet, brushless DC	
Speed	rpm	variable speed
Resistance, all 3 windings (25°C)	mΩ	210

### Design

Displacement	cm <sup>3</sup>	1.41
Oil quantity (type)	cm <sup>3</sup>	75 (polyolester)
Maximum refrigerant charge	g	70
Free gas volume in compressor	cm <sup>3</sup>	500
Weight - Compressor/Electronic unit	kg	2.1 / 0.11

### Standard battery protection settings (refer to 101N2130 Instructions for optional settings)

Voltage (0.1 steps)			Min. value	Default	Max. value	
12V	± 0.3V DC, all values	Cut out	VDC	9.6	10.4	17
		Cut in diff.	VDC	0.5	1.3	10
24V	± 0.3V DC, all values	Cut out	VDC	19	21.3	27
		Cut in diff.	VDC	0.5	1.3	10

### Dimensions

Height	mm	A	96.25
		B	91.25
		B1	88.00
		B2	25.20
Suction connector	location/I.D. mm   angle	C	6.2   25°
	material   comment	Cu-plated steel   Al cap	
Process connector	location/I.D. mm   angle	D	6.2   25°
	material   comment	Cu-plated steel   Al cap	
Discharge connector	location/I.D. mm   angle	E	5.0   0°
	material   comment	Cu-plated steel   Al cap	
Connector tolerance	I.D. mm	±0.09, on 5.0 +0.12/+0.20	

- S = Static cooling normally sufficient
- O = Oil cooling
- F<sub>1</sub> = Fan cooling 1.5 m/s  
(compressor compartment temperature equal to ambient temperature)
- F<sub>2</sub> = Fan cooling 3.0 m/s necessary
- SG = Suction gas cooling normally sufficient
- = not applicable in this area

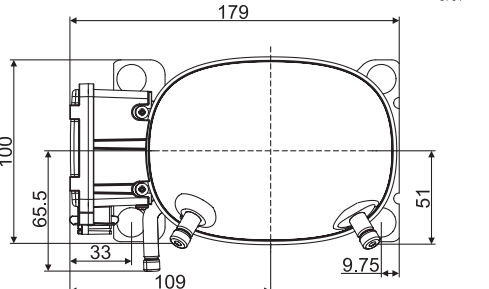
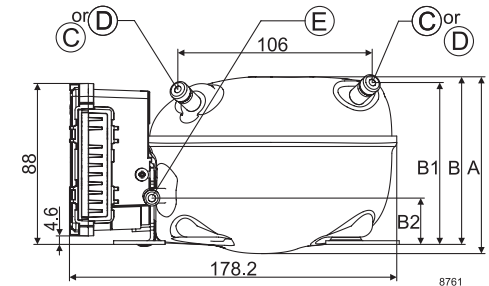
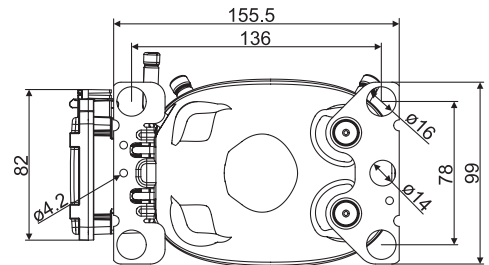

# Performance Data with Refrigerant R134a

**Capacity (EN 12900 Household/CECOMAF), R134a** 12V DC, static cooling **watt**

rpm \ °C	-30	-25	-23.3	-20	-15	-10	-5	0	5	7.2	10	15
2,000		9	11	15	22	31	42	54	68	75	84	101
3,000	9	16	19	26	37	51	67	85	105	115	128	152
3,500	10	20	23	31	45	61	80	101	124	135	150	178
4,000	12	23	27	36	52	71	92	116	142	155	172	203

**Capacity (ASHRAE LBP), R134a** 12V DC, static cooling **watt**

rpm \ °C	-30	-25	-23.3	-20	-15	-10	-5	0	5	7.2	10	15
2,000		12	14	19	28	39	52	68	85	93	105	126
3,000	11	20	24	32	47	64	83	106	131	143	159	190
3,500	13	24	29	38	56	76	99	125	154	168	186	222
4,000	15	29	34	45	65	88	114	144	177	193	214	254

**Power consumption, R134a** 12V DC, static cooling **watt**

rpm \ °C	-30	-25	-23.3	-20	-15	-10	-5	0	5	7.2	10	15
2,000		16	17	19	22	25	29	34	39	41	44	50
3,000	19	24	26	29	34	39	45	50	56	59	62	68
3,500	23	29	31	35	41	47	53	59	65	68	71	78
4,000	27	34	36	41	48	55	61	68	75	77	81	87

**Current consumption, R134a (for 24V applications the following must be halved)** **A**

rpm \ °C	-30	-25	-23.3	-20	-15	-10	-5	0	5	7.2	10	15
2,000		1.25	1.33	1.48	1.74	2.02	2.33	2.66	3.02	3.18	3.40	3.81
3,000	1.49	1.84	1.96	2.20	2.59	2.99	3.40	3.84	4.29	4.49	4.75	5.24
3,500	1.77	2.19	2.34	2.62	3.07	3.53	4.00	4.48	4.98	5.20	5.49	6.01
4,000	2.09	2.58	2.75	3.08	3.59	4.11	4.64	5.17	5.71	5.95	6.26	6.82

**COP (EN 12900 Household/CECOMAF), R134a** 12V DC, static cooling **W/W**

rpm \ °C	-30	-25	-23.3	-20	-15	-10	-5	0	5	7.2	10	15
2,000		0.59	0.66	0.81	1.03	1.24	1.43	1.60	1.76	1.82	1.90	2.03
3,000	0.45	0.67	0.74	0.89	1.10	1.30	1.50	1.69	1.88	1.96	2.06	2.24
3,500	0.46	0.68	0.75	0.89	1.10	1.30	1.51	1.70	1.90	1.99	2.10	2.29
4,000	0.45	0.68	0.75	0.89	1.09	1.30	1.50	1.70	1.91	2.00	2.12	2.32

**COP (ASHRAE LBP), R134a** 12V DC, static cooling **W/W**

rpm \ °C	-30	-25	-23.3	-20	-15	-10	-5	0	5	7.2	10	15
2,000		0.74	0.83	1.01	1.29	1.55	1.79	2.01	2.21	2.29	2.39	2.56
3,000	0.57	0.84	0.93	1.11	1.37	1.62	1.87	2.12	2.35	2.46	2.59	2.82
3,500	0.58	0.85	0.94	1.11	1.37	1.62	1.87	2.12	2.37	2.48	2.63	2.88
4,000	0.58	0.85	0.94	1.11	1.36	1.61	1.87	2.12	2.38	2.5	2.65	2.92

**Operational errors (TOOL4COOL® or LED flashes)**

Error code or LED flashes	Error type
	Can be read out in the software <b>TOOL4COOL®</b>
<b>6</b>	<b>Thermostat failure</b> (If the NTC thermistor is short-circuit or has no connection, the electronic unit will enter manual mode).
<b>5</b>	<b>Thermal cut-out of electronic unit</b> (If the refrigeration system has been too heavily loaded, or if the ambient temperature is high, the electronic unit will run too hot).
<b>4</b>	<b>Minimum motor speed error</b> (If the refrigeration system is too heavily loaded, the motor cannot maintain minimum speed at approximately 1,850 rpm).
<b>3</b>	<b>Motor start error</b> (The rotor is blocked or the differential pressure in the refrigeration system is too high (>5 bar)).
<b>2</b>	<b>Fan over-current cut-out</b> (The fan loads the electronic unit with more than 0.65A <sub>peak</sub> ).
<b>1</b>	<b>Battery protection cut-out</b> (The voltage is outside the cut-out setting).

**Wire Dimensions DC**

Cross section [mm <sup>2</sup> ]	Size		Max. length* 12V operation		Max. length* 24V operation	
	AWG	[Gauge]	[m]	[ft.]	[m]	[ft.]
2.5	12		2.5	8	5	16
4	12		4	13	8	26
6	10		6	20	12	39
10	8		10	33	20	66

\*Length between battery and electronic unit

**COP (EN 12900 Household/CECOMAF), R134a** 12V DC, static cooling **W/W**

rpm \ °C	-30	-25	-23.3	-20	-15	-10	-5	0	5	7.2	10	15
2,000		0.59	0.66	0.81	1.03	1.24	1.43	1.60	1.76	1.82	1.90	2.03
3,000	0.45	0.67	0.74	0.89	1.10	1.30	1.50	1.69	1.88	1.96	2.06	2.24
3,500	0.46	0.68	0.75	0.89	1.10	1.30	1.51	1.70	1.90	1.99	2.10	2.29
4,000	0.45	0.68	0.75	0.89	1.09	1.30	1.50	1.70	1.91	2.00	2.12	2.32

**COP (ASHRAE LBP), R134a** 12V DC, static cooling **W/W**

rpm \ °C	-30	-25	-23.3	-20	-15	-10	-5	0	5	7.2	10	15
2,000		0.74	0.83	1.01	1.29	1.55	1.79	2.01	2.21	2.29	2.39	2.56
3,000	0.57	0.84	0.93	1.11	1.37	1.62	1.87	2.12	2.35	2.46	2.59	2.82
3,500	0.58	0.85	0.94	1.11	1.37	1.62	1.87	2.12	2.37	2.48	2.63	2.88
4,000	0.58	0.85	0.94	1.11	1.36	1.61	1.87	2.12	2.38	2.5	2.65	2.92

**Accessories for BD1.4F-VSD-HD**

Accessories for BD1.4F-VSD-HD	Code number
Bolt joint for one compressor	Ø:16 mm 118-1917
Bolt joint in quantities	Ø:16 mm 118-1918
Snap-on in quantities	Ø:16 mm 118-1919
Terminal cover for electronic unit	105N9120
Automobile fuse DIN 7258	12V: 15A 24V: 15A
Main switch	min. 20A Not deliverable from Secop

**Test conditions**

Test conditions	EN 12900 CECOMAF	ASHRAE LBP
Condensing temperature	55°C	54.4°C
Ambient temperature	32°C	32°C
Suction gas temperature	32°C	32°C
Liquid temperature	no subcooling	32°C

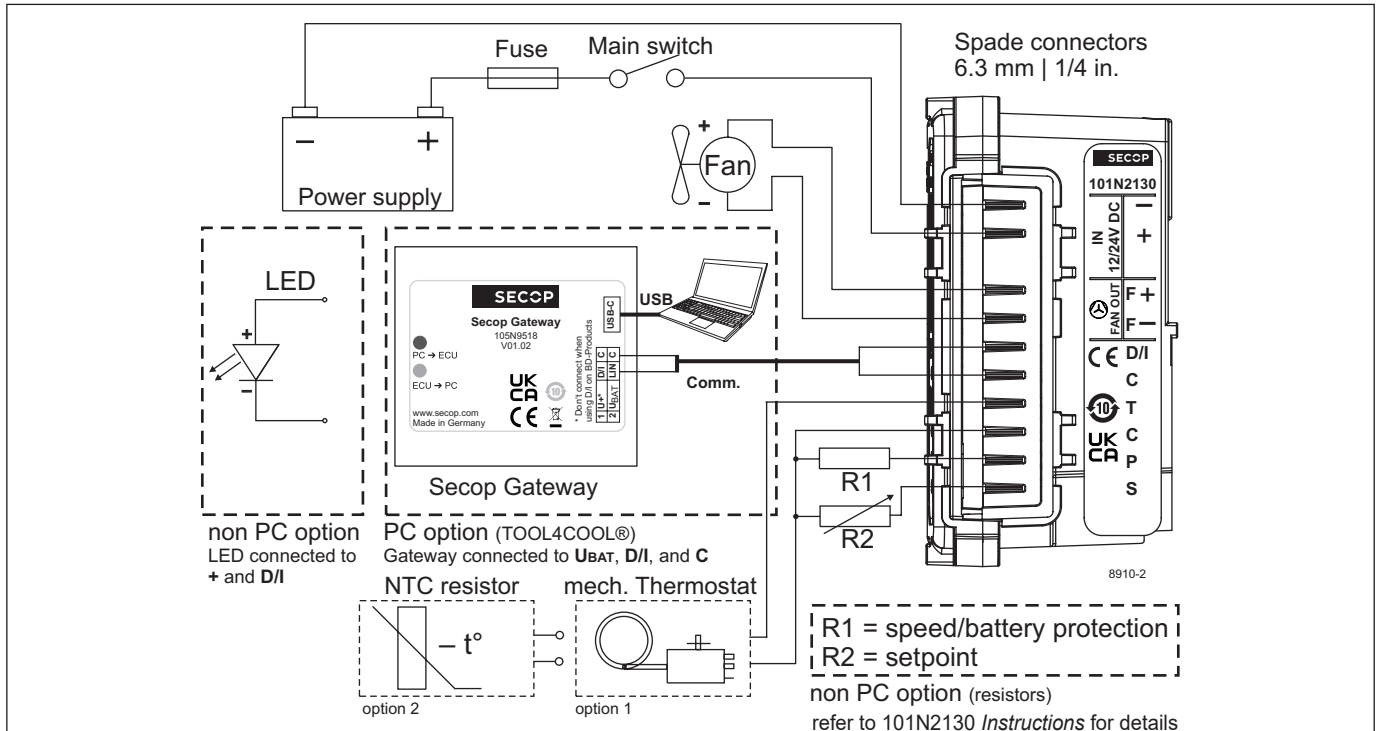

# Performance Data with Refrigerant R1234yf

**Capacity (EN 12900 Household/CECOMAF), R1234yf** 12V DC, static cooling **watt**

rpm \ °C	-30	-25	-23.3	-20	-15	-10	-5	0	5	7.2	10	15
2,000		10	12	16	23	32	42	53	65	70	78	91
3,000	10	17	21	27	39	52	67	83	100	108	118	137
3,500	11	20	24	32	45	60	78	97	118	128	141	166
4,000	13	24	29	38	54	71	91	111	134	144	158	182

**Capacity (ASHRAE LBP), R1234yf** 12V DC, static cooling **watt**

rpm \ °C	-30	-25	-23.3	-20	-15	-10	-5	0	5	7.2	10	15
2,000		13	15	21	30	42	55	69	85	92	102	120
3,000	13	23	27	35	50	68	87	108	130	141	155	180
3,500	14	26	31	41	58	78	101	126	154	167	184	217
4,000	17	32	38	50	70	93	118	145	174	188	206	239

**Power consumption, R1234yf** 12V DC, static cooling **watt**

rpm \ °C	-30	-25	-23.3	-20	-15	-10	-5	0	5	7.2	10	15
2,000		17	18	20	23	27	30	34	38	40	42	46
3,000	22	27	28	31	36	41	46	51	55	57	60	64
3,500	26	31	33	37	43	49	54	59	64	67	69	74
4,000	30	37	40	44	51	57	63	68	74	76	78	83

**Current consumption, R1234yf (for 24V applications the following must be halved)** **A**

rpm \ °C	-30	-25	-23.3	-20	-15	-10	-5	0	5	7.2	10	15
2,000		1.39	1.47	1.62	1.88	2.14	2.41	2.69	2.97	3.09	3.25	3.53
3,000	1.66	2.02	2.15	2.39	2.76	3.13	3.50	3.86	4.22	4.38	4.58	4.93
3,500	1.98	2.40	2.54	2.82	3.24	3.66	4.08	4.50	4.92	5.11	5.34	5.76
4,000	2.34	2.83	3.00	3.32	3.81	4.28	4.75	5.20	5.64	5.83	6.06	6.47

**COP (EN 12900 Household/CECOMAF), R1234yf** 12V DC, static cooling **W/W**

rpm \ °C	-30	-25	-23.3	-20	-15	-10	-5	0	5	7.2	10	15
2,000		0.58	0.65	0.79	1.00	1.20	1.38	1.55	1.70	1.76	1.84	1.97
3,000	0.44	0.66	0.73	0.87	1.07	1.26	1.45	1.63	1.81	1.89	1.98	2.15
3,500	0.42	0.64	0.71	0.84	1.05	1.25	1.44	1.64	1.84	1.93	2.04	2.24
4,000	0.43	0.66	0.73	0.86	1.06	1.25	1.44	1.63	1.82	1.90	2.01	2.20

**COP (ASHRAE LBP), R1234yf** 12V DC, static cooling **W/W**

rpm \ °C	-30	-25	-23.3	-20	-15	-10	-5	0	5	7.2	10	15
2,000		0.75	0.85	1.03	1.3	1.56	1.81	2.03	2.24	2.33	2.44	2.62
3,000	0.59	0.86	0.95	1.13	1.39	1.65	1.9	2.14	2.38	2.48	2.61	2.84
3,500	0.55	0.83	0.92	1.09	1.36	1.62	1.88	2.14	2.40	2.52	2.67	2.94
4,000	0.58	0.86	0.95	1.13	1.38	1.63	1.88	2.13	2.38	2.49	2.63	2.90

**Operational errors (TOOL4COOL® or LED flashes)**

Error code or LED flashes	Error type
	Can be read out in the software <b>TOOL4COOL®</b>
<b>6</b>	<b>Thermostat failure</b> (If the NTC thermistor is short-circuit or has no connection, the electronic unit will enter manual mode).
<b>5</b>	<b>Thermal cut-out of electronic unit</b> (If the refrigeration system has been too heavily loaded, or if the ambient temperature is high, the electronic unit will run too hot).
<b>4</b>	<b>Minimum motor speed error</b> (If the refrigeration system is too heavily loaded, the motor cannot maintain minimum speed at approximately 1,850 rpm).
<b>3</b>	<b>Motor start error</b> (The rotor is blocked or the differential pressure in the refrigeration system is too high (>5 bar)).
<b>2</b>	<b>Fan over-current cut-out</b> (The fan loads the electronic unit with more than 0.65A <sub>peak</sub> ).
<b>1</b>	<b>Battery protection cut-out</b> (The voltage is outside the cut-out setting).

**Wire Dimensions DC**

Cross section [mm²]	Size		Max. length* 12V operation		Max. length* 24V operation	
	AWG	[Gauge]	[m]	[ft.]	[m]	[ft.]
2.5	12		2.5	8	5	16
4	12		4	13	8	26
6	10		6	20	12	39
10	8		10	33	20	66

\*Length between battery and electronic unit

**COP (EN 12900 Household/CECOMAF), R1234yf** 12V DC, static cooling **W/W**

rpm \ °C	-30	-25	-23.3	-20	-15	-10	-5	0	5	7.2	10	15
2,000		0.58	0.65	0.79	1.00	1.20	1.38	1.55	1.70	1.76	1.84	1.97
3,000	0.44	0.66	0.73	0.87	1.07	1.26	1.45	1.63	1.81	1.89	1.98	2.15
3,500	0.42	0.64	0.71	0.84	1.05	1.25	1.44	1.64	1.84	1.93	2.04	2.24
4,000	0.43	0.66	0.73	0.86	1.06	1.25	1.44	1.63	1.82	1.90	2.01	2.20

**Accessories for BD1.4F-VSD-HD**

Accessories for BD1.4F-VSD-HD	Code number
Bolt joint for one compressor	Ø:16 mm 118-1917
Bolt joint in quantities	Ø:16 mm 118-1918
Snap-on in quantities	Ø:16 mm 118-1919
Terminal cover for electronic unit	105N9120
Automobile fuse DIN 7258	12V: 15A 24V: 15A
Main switch	min. 20A Not deliverable from Secop

**COP (ASHRAE LBP), R1234yf** 12V DC, static cooling **W/W**

rpm \ °C	-30	-25	-23.3	-20	-15	-10	-5	0	5	7.2	10	15
2,000		0.75	0.85	1.03	1.3	1.56	1.81	2.03	2.24	2.33	2.44	2.62
3,000	0.59	0.86	0.95	1.13	1.39	1.65	1.9	2.14	2.38	2.48	2.61	2.84
3,500	0.55	0.83	0.92	1.09	1.36	1.62	1.88	2.14	2.40	2.52	2.67	2.94
4,000	0.58	0.86	0.95	1.13	1.38	1.63	1.88	2.13	2.38	2.49	2.63	2.90

**Test conditions**

Test conditions	EN 12900 CECOMAF	ASHRAE LBP
Condensing temperature	55°C	54.4°C
Ambient temperature	32°C	32°C
Suction gas temperature	32°C	32°C
Liquid temperature	no subcooling	32°C

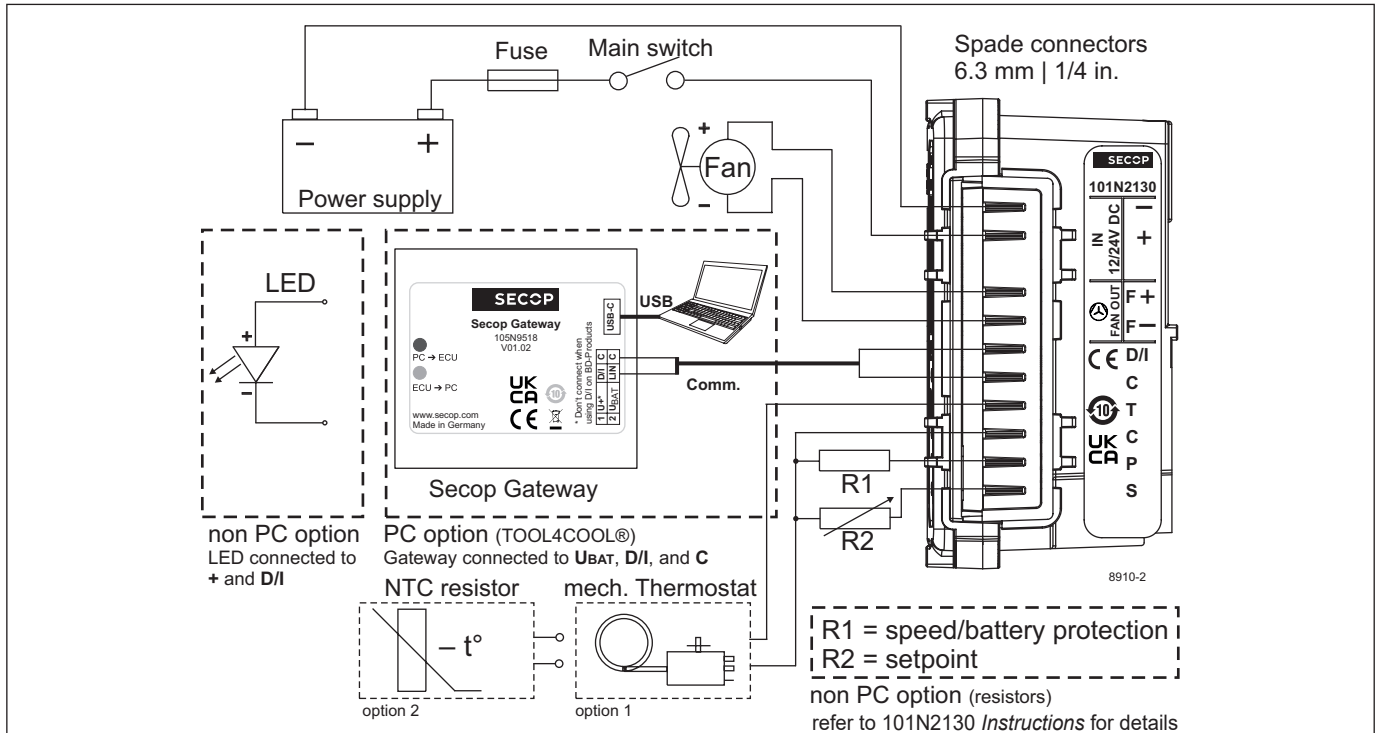

Secop accepts no responsibility for possible errors in catalogs, brochures, and other printed material. Secop reserves the right to alter its products without notice. This also applies to products already on order provided that such alterations can be made without substantial changes being necessary to specifications already agreed. All trademarks in this material are the property of the respective companies. Secop and the Secop logotype are trademarks of Secop GmbH. All rights reserved. [www.secop.com](http://www.secop.com)



Instructions for Electronic Units  
are available for download on  
[www.secop.com](http://www.secop.com)



# BD Compressors



## Service/Repair



### BD Nano



**! max. 150°C/302°F !**  
at socket

brazing solder: silver with flux

Do not heat up the bottom of the discharge connector directly.  
Do not braze longer than 10 seconds and wait for 5 minutes for the next soldering attempt (Product Bulletin DES.N.101.M1).

### BD Micro

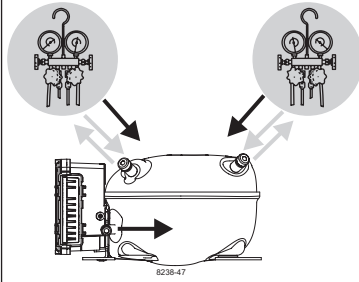

### BD P-Housing

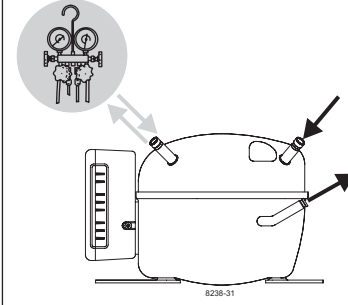

### BD T-Housing

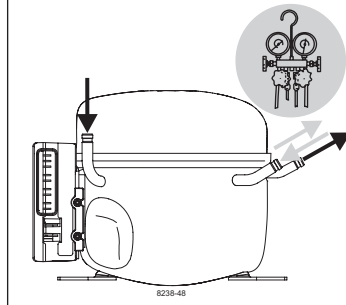

Secop accepts no responsibility for possible errors in catalogs, brochures, and other printed material. Secop reserves the right to alter its products without notice. This also applies to products already on order provided that such alterations can be made without subsequent changes being necessary to specifications already agreed. All trademarks in this material are the property of the respective companies. Secop and the Secop logotype are trademarks of Secop GmbH. All rights reserved. [www.secop.com](http://www.secop.com)