

## Single Pack SC18CL 220-240V 50Hz CSCR

Single pack code number: **195B4072**

Position	Title	Code	Amount
1	Compressor SC18CL	104L2132	1
2	SC starting device (550mm)	117-7027	1
3	Cord relief	103N1004	1
4	Cover	103N2009	1
5	Bolt joint for one compressor   M6   ø16mm	118-1917	1

**Secop GmbH** • Lise-Meitner-Straße 29 • 24941 Flensburg, Germany • Tel: +49 461 4941 0 • [www.secop.com](http://www.secop.com)

Secop accepts no responsibility for possible errors in catalogs, brochures, and other printed material. Secop reserves the right to alter its products without notice. This also applies to products already on order provided that such alterations can be made without subsequent changes being necessary to specifications already agreed. All trademarks in this material are the property of the respective companies. Secop and the Secop logotype are trademarks of Secop GmbH. All rights reserved.

## Model

Designation	<b>SC18CL</b>	220-240V/50Hz 1~	Sales code:	<b>104L2132</b>
-------------	---------------	------------------	-------------	-----------------

## Compressor design

Oil type	Polyolester	Refrigerant(s)	<b>R404A, R507</b>
Oil viscosity	32cST	Displacement	17,69cm <sup>3</sup> / 1,08cu.in
Oil quantity	550cm <sup>3</sup> / 18,6fl.oz	Compressors on pallet	80
Refr. charge - tech. limit	1300g / 45,9oz		
Free gas volume comp.	1460cm <sup>3</sup> / 49,4fl.oz		
Weight	13,8kg / 30,4lbs		
Motor protection	1# internal		
Winding resistance main	3,7Ω (at 25°C)		
Winding resistance aux	14Ω (at 25°C)		
Max. winding temp.	125°C / 257°F		
Max. discharge temp.	135°C / 275°F		



## General - Configurations with SC18CL

	<b>Conf. 1</b>
Motorconfiguration	CSCR
Power supply (nominal)	220-240V/50Hz
Number of phases	1
Voltage range	198-254V
Approvals	CCC, VDE
Starting torque	HST
Note	- / -

## Applications with SC18CL

	<b>Conf. 1</b>
Refrigerant	R404A
Application	LBP+MBP
System cooling	fan 3m/s
Hot gas defrost	OK
Long interval pull down	OK

## Electrical data - Configurations with SC18CL

	<b>Conf. 1</b>
Starting device type	relay
Run capacitor	10μF
Start capacitor	80μF
LRA (locked rotor amps / 4s)	20,43A
RLA (rated load amps / 1s)	4,2A
Cut in current	20,43A

## Model

Designation

**SC18CL**

220-240V/50Hz 1~

Sales code:

**104L2132**

## Compressor dimensions

Housing	A Height	219mm / 8,62in
	B Height	213mm / 8,39in
	C Length shell	239mm / 9,41in
	D Length w. cover	255mm / 10,04in
	E Width	151mm / 5,94in

Connectors	Suction X	Discharge Y	Process Z
Diameter [mm]	øi 9,54-9,72	øi 6,41-6,59	øi 6,41-6,59
(i:inside, o:outside) [in]	øi 0,38-0,38	øi 0,25-0,26	øi 0,25-0,26
Material	copper	copper	copper
Horizontal angle ±2°	37°	37°	143°
Vertical angle ±2°	30°	0°	150°
Position l/h/w [mm]	107/193/55	115/110/63	-107/193/55
[in]	4,2/7,6/2,2	4,5/4,3/2,5	-4,2/7,6/2,2
Straight tube l. [mm]	12	12	12
[in]	0,5	0,5	0,5

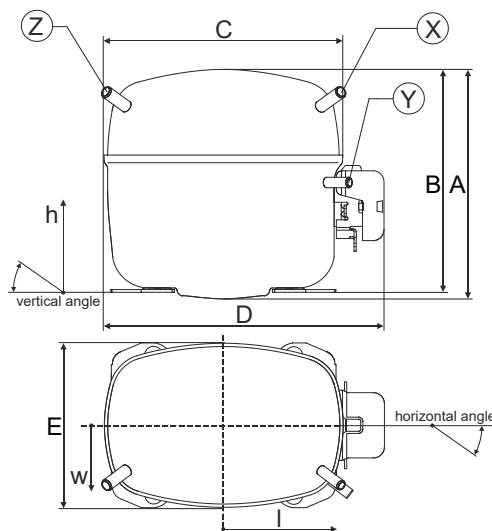

## Compressor fixation

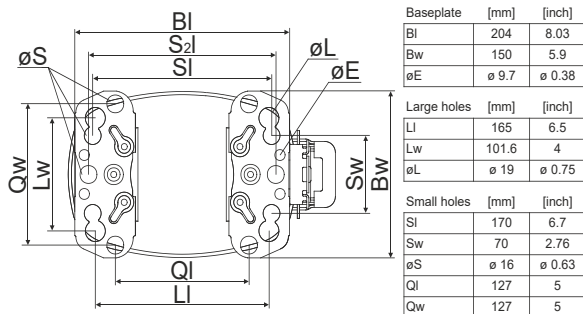

### Bolt joint

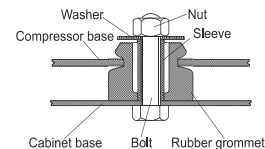

### Snap-on

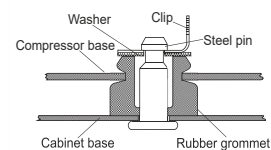

## Mounting accessories

Mounting accessories	one comp.	multi pack
Bolt joint   M6   ø16mm	118-1917	118-1918
Bolt joint   ø1/4"   ø16mm	118-1946	
Bolt joint   ø1/4"   ø19mm	118-1949	
Snap-on   ø7,3   ø16mm	118-1947	118-1919

## Application notes

Provision for PE Grounding is located at the PE Stamp on the compressor

## Model

Designation	<b>SC18CL</b>	<b>220-240V/50Hz</b>	<b>Conf. 1</b>	Sales code:	<b>104L2132</b>
-------------	---------------	----------------------	----------------	-------------	-----------------

## Configuration

Motorconfiguration	CSCR
Power supply (nominal)	220-240V/50Hz 1~
Refrigerant	R404A
Application	LBP+MBP
Voltage range	198-254V
Starting torque	HST
Approvals	CCC VDE

## Electrical accessories / wiring diagram

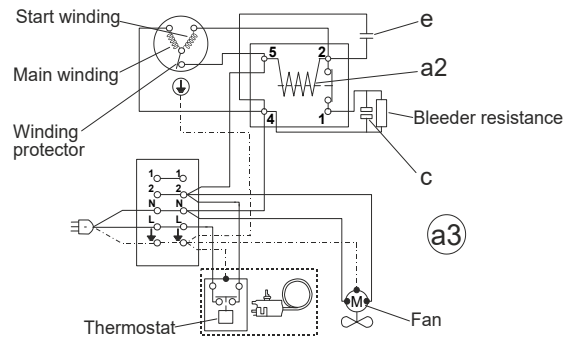
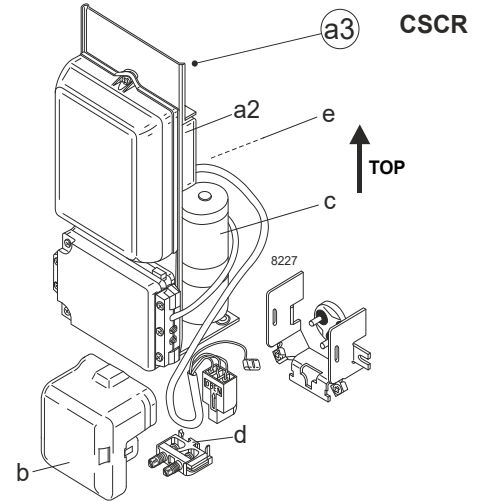

## Ambient/ machine room temperatures minimum /maximum

Ambient temperature range:	10 - 38°C / 50 - 101°F
Machine room temperature range:	10 - 43°C / 50 - 110°F
Compressor cooling:	fan 3m/s

## Operation Limits

### Operation pressure range

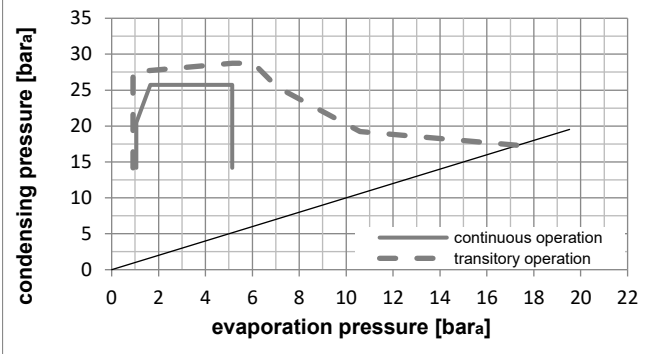
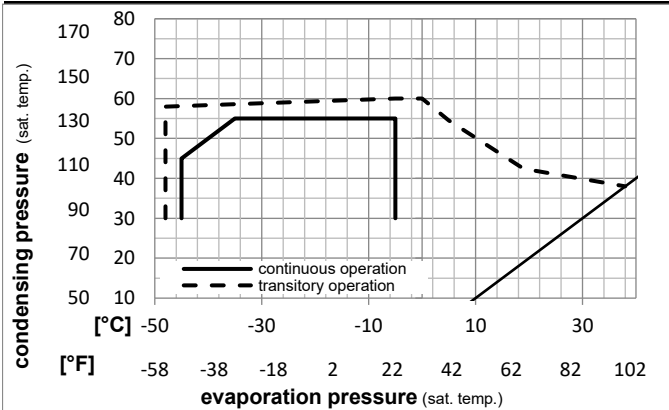

### Components

a3	SC starter kit (550mm)	117-7027
b	plastic cover	103N2009
d	cord relief	103N1004

### Alternative components

a3	SC starter kit (1000mm)	117-7040
a3	SC starter kit (650mm)	117-7046
c	start capacitor (80µF)	117U5373
e	run capacitor (10µF, 6.3mm)	117-7112

## Model

Designation	<b>SC18CL</b>	<b>220-240V/50Hz</b>	Conf. 1	Sales code:	<b>104L2132</b>
-------------	---------------	----------------------	---------	-------------	-----------------

## Optimization + standard conditions

R404A, 220V/50Hz, CSCR, fan 3m/s, CCC, VDE

	Evaporating pressure (saturation temperature)				Condensing pressure (saturation temperature)			Return gas temp.	Liquid temp.	Cooling capacity	COP	EER	Power consumption			ASHRAE LBP
	pe	pc	RGT	Tliq	[W]	[Btu/h]	[kcal/h]						P1	I	Ref. mass flow	
	[°C]	[°F]	[°C]	[°F]	[W]	[Btu/h]	[kcal/h]	[W/W]	[Btu/Wh]	[kcal/Wh]	[W]	[A]	[kg/h]			
	-23	54	32	32	800,9	2735	689,3	1,21	4,14	1,04	660,0	3,78	18,66	ASHRAE LBP		
	-10	130	90	90												
	-25	55	32	55	538,7	1840	463,6	0,86	2,92	0,74	629,0	3,65	16,83	cecomaf LBP		
	-13	131	90	131												
	-35	40	20	40	436,2	1490	375,4	0,97	3,30	0,83	451,0	3,01	11,85	EN12900 LBP		
	-31	104	68	104												
	-23	49	4,4	49	609,4	2081	524,5	0,93	3,19	0,80	652,4	3,75	21,58	ARI540 LBP		
	-10	120	40	120												
	-23	41	32	32	949,2	3242	816,9	1,51	5,17	1,30	627,4	3,66	22,12	AHAM LBP		
	-10	105	90	90												
	-35	45	32	45	394,5	1347	339,6	0,87	2,96	0,75	455,2	3,02	10,55	opt		
	-31	113	90	113												

## Performance tables

R404A, 220V/50Hz, CSCR, fan 3m/s, CCC, VDE

	pe		Cooling capacity			COP	EER	P1	I	m	
	[°C]	[°F]	[W]	[Btu/h]	[kcal/h]	[W/W]	[Btu/Wh]	[kcal/Wh]	[W]	[A]	[kg/h]
[°C / °F]	-45	-49	166,7	569	143,5	0,57	1,94	0,49	293,6	2,61	4,43
cond. pressure	-35	-31	394,5	1347	339,6	0,87	2,96	0,75	455,2	3,02	10,55
pc= 45/113	-30	-22	541,8	1850	466,3	1,01	3,47	0,87	534,0	3,29	14,54
return gas temp.	-25	-13	715,3	2443	615,6	1,16	3,97	1,00	614,8	3,60	19,30
RGT= 32/90	-20	-4	918,3	3136	790,3	1,31	4,48	1,13	700,1	3,96	24,92
liquid temp	-15	5	1153,9	3941	993,0	1,46	4,97	1,25	792,3	4,36	31,52
Tliq= 45/113	-5	23	1734,8	5925	1493,0	1,72	5,88	1,48	1007,6	5,29	48,23
[°C / °F]	-45	-49	83,9	286	72,2	0,33	1,14	0,29	252,2	2,47	2,58
cond. pressure	-35	-31	275,1	940	236,8	0,62	2,11	0,53	444,8	2,97	8,51
pc= 55/131	-30	-22	396,3	1353	341,1	0,74	2,52	0,64	536,7	3,29	12,32
return gas temp	-25	-13	538,7	1840	463,6	0,86	2,92	0,74	629,0	3,65	16,83
RGT= 32/90	-20	-4	705,3	2409	606,9	0,97	3,33	0,84	724,2	4,05	22,19
liquid temp	-15	5	899,2	3071	773,9	1,09	3,72	0,94	824,7	4,50	28,52
Tliq= 55/131	-5	23	1381,5	4718	1188,9	1,31	4,49	1,13	1051,7	5,52	44,72

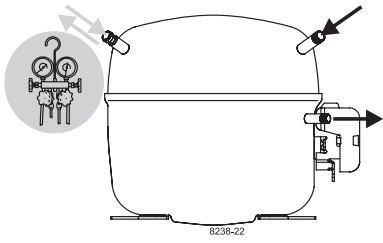

# SC Compressors

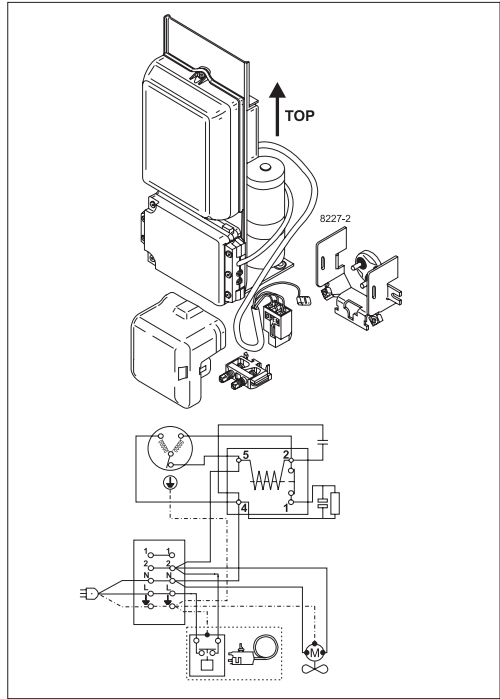
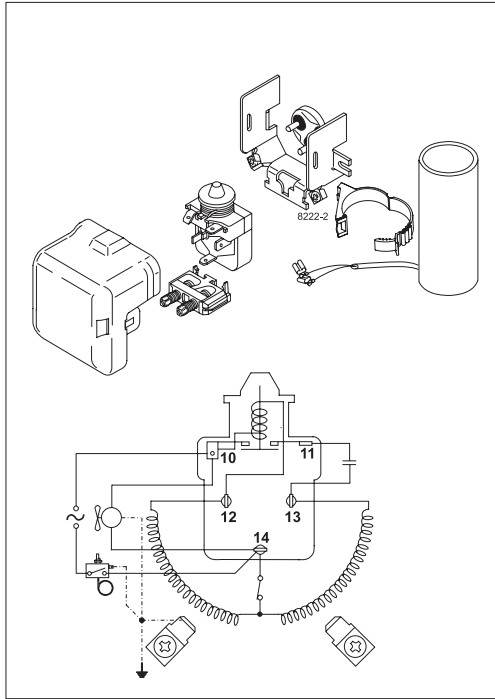
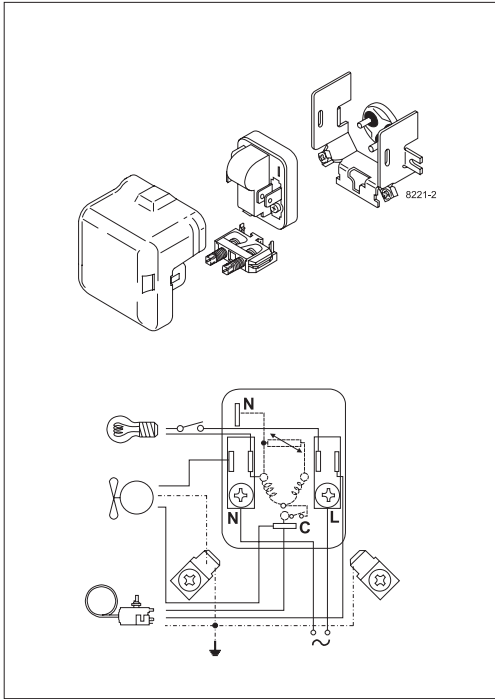

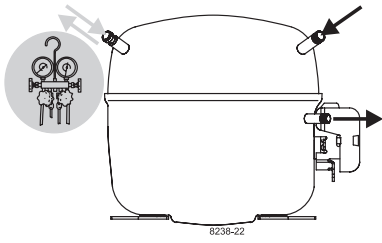

# SC Compressors

## Service/Repair – R290

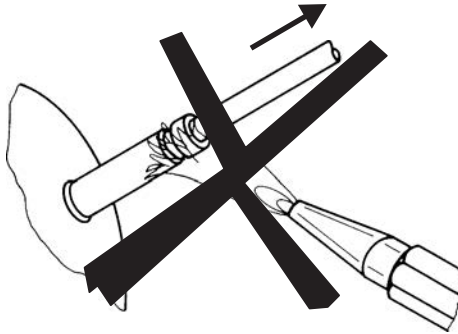

8545

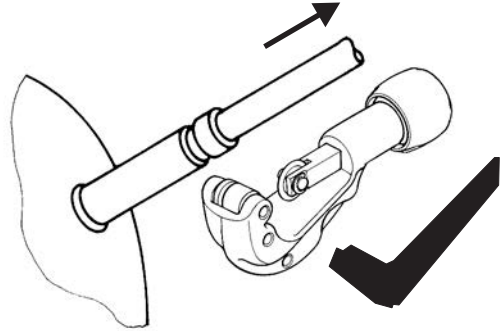

Secop accepts no responsibility for possible errors in catalogs, brochures, and other printed material. Secop reserves the right to alter its products without notice. This also applies to products already on order provided that such alterations can be made without subsequent changes being necessary to specifications already agreed. All trademarks in this material are the property of the respective companies. Secop and the Secop logotype are trademarks of Secop GmbH. All rights reserved. [www.secop.com](http://www.secop.com)