

Single Pack SC15FT 220-240V 50/60Hz CSIR

Single pack code number: **195B4097**

Position	Title	Code	Amount
1	Compressor SC15FT	104G8505	1
2	Starting relay	117U6005	1
3	Starting capacitor (80 μ F 220V, 6.3mm)	117U5017	1
4	Cord relief	103N1004	1
5	Cover	103N2009	1
6	Bolt joint for one compressor M6 \varnothing 16mm	118-1917	1

Secop GmbH • Lise-Meitner-Straße 29 • 24941 Flensburg, Germany • Tel: +49 461 4941 0 • www.secop.com

Secop accepts no responsibility for possible errors in catalogs, brochures, and other printed material. Secop reserves the right to alter its products without notice. This also applies to products already on order provided that such alterations can be made without subsequent changes being necessary to specifications already agreed. All trademarks in this material are the property of the respective companies. Secop and the Secop logotype are trademarks of Secop GmbH. All rights reserved.

Model

Designation	SC15FT	220-240V/50Hz 1~ 220-240V/60Hz 1~	Sales code:	104G8505
-------------	---------------	-----------------------------------	-------------	-----------------

Compressor design

Oil type	Polyolester	Refrigerant(s)	R134a
Oil viscosity	32cST	Displacement	15,28cm ³ / 0,93cu.in
Oil quantity	556cm ³ / 18,8fl.oz	Compressors on pallet	80
Refr. charge - tech. limit	1300g / 45,9oz		
Free gas volume comp.	1410cm ³ / 47,7fl.oz		
Weight	12,9kg / 28,4lbs		
Motor protection	1# internal		
Winding resistance main	5,13Ω (at 25°C)		
Winding resistance aux	13,51Ω (at 25°C)		
Max. winding temp.	125°C / 257°F		
Max. discharge temp.	135°C / 275°F		



General - Configurations with SC15FT

	Conf. 1	Conf. 2	Conf. 3	Conf. 4
Motorconfiguration	CSIR	CSIR	RSIR	RSIR
Power supply (nominal)	220-240V/50Hz	208-230V/60Hz	220-240V/50Hz	208-230V/60Hz
Number of phases	1	1	1	1
Voltage range	187-254V	198-254V	187-254V	198-254V
Approvals	CCC, EAC, VDE, KC	CCC, EAC, VDE, KC	CCC, EAC, VDE, KC	CCC, EAC, VDE, KC
Starting torque	HST	HST	LST	LST
Note	- / -			

Applications with SC15FT

	Conf. 1	Conf. 2	Conf. 3	Conf. 4
Refrigerant	R134a	R134a	R134a	R134a
Application	LBP	LBP	LBP	LBP
System cooling	fan 1,5m/s	fan 1,5m/s	fan 1,5m/s	fan 1,5m/s
Hot gas defrost	OK	OK	OK	OK
Long interval pull down	OK	OK	OK	OK

Electrical data - Configurations with SC15FT

	Conf. 1	Conf. 2	Conf. 3	Conf. 4
Starting device type	relay	relay	PTC	PTC
Run capacitor	-/-	-/-	-/-	-/-
Start capacitor	80μF	80μF	-/-	-/-
LRA (locked rotor amps / 4s)				
RLA (rated load amps / 1s)	-/-A	-/-A	-/-A	-/-A
Cut in current				

Model

Designation

SC15FT

220-240V/50Hz 1~ 220-240V/60Hz 1~

Sales code:

104G8505

Compressor dimensions

Housing	A Height	209mm / 8,23in
	B Height	203mm / 7,99in
	C Length shell	218mm / 8,58in
	D Length w. cover	255mm / 10,04in
	E Width	151mm / 5,94in

Connectors	Suction X	Discharge Y	Process Z
Diameter [mm]	øi 10,11-10,29	øi 6,11-6,29	øi 6,11-6,29
(i:inside, o:outside) [in]	øi 0,4-0,41	øi 0,24-0,25	øi 0,24-0,25
Material	copper	copper	copper
Horizontal angle ±2°	37°	37°	143°
Vertical angle ±2°	30°	0°	150°
Position l/h/w [mm]	107/183/55	115/100/63	-107/183/55
[in]	4,2/7,2/2,2	4,5/3,9/2,5	-4,2/7,2/2,2
Straight tube l. [mm]	12	12	12
[in]	0,5	0,5	0,5

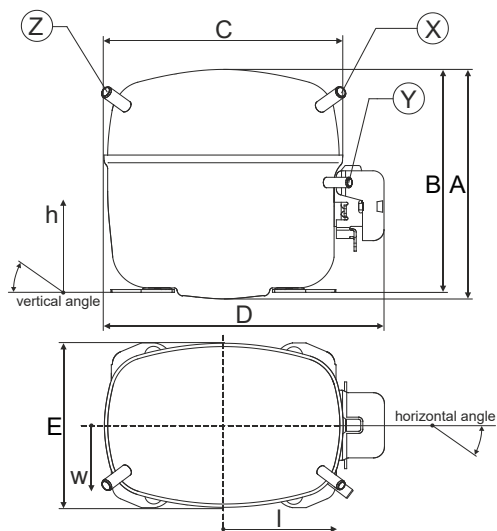

Compressor fixation



Bolt joint



Snap-on

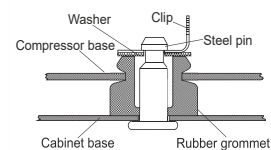

Mounting accessories

Mounting accessories	one comp.	multi pack
Bolt joint M6 ø16mm	118-1917	118-1918
Bolt joint ø1/4" ø16mm	118-1946	
Bolt joint ø1/4" ø19mm	118-1949	
Snap-on ø7,3 ø16mm	118-1947	118-1919

Application notes

Provision for PE Grounding is located at the PE Stamp on the compressor

Model

Designation	SC15FT	220-240V/50Hz	Conf. 1	Sales code:	104G8505
-------------	---------------	----------------------	----------------	-------------	-----------------

Configuration

Motorconfiguration	CSIR
Power supply (nominal)	220-240V/50Hz 1~
Refrigerant	R134a
Application	LBP
Voltage range	187-254V
Starting torque	HST
Approvals	CCC EAC VDE KC

Electrical accessories / wiring diagram

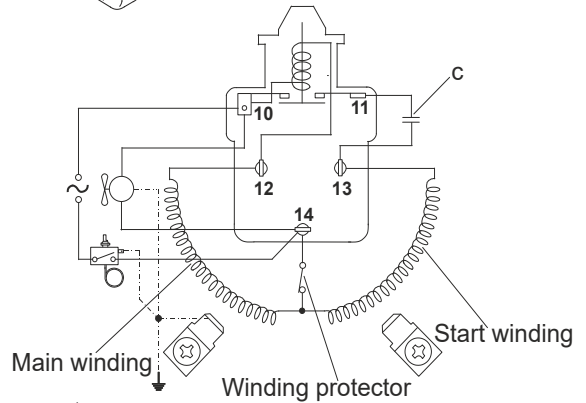
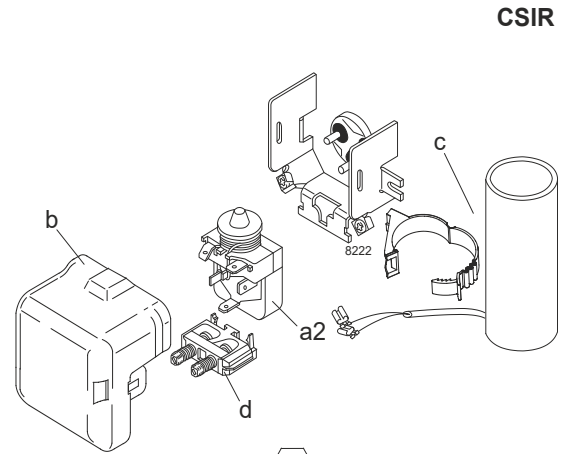

Ambient/ machine room temperatures minimum /maximum

Ambient temperature range:	10 - 43°C / 50 - 110°F
Machine room temperature range:	10 - 48°C / 50 - 119°F
Compressor cooling:	fan 3m/s

Operation Limits

F1 at 43°C ambient temperature possible at 220V nominal (187-242V)

Operation pressure range

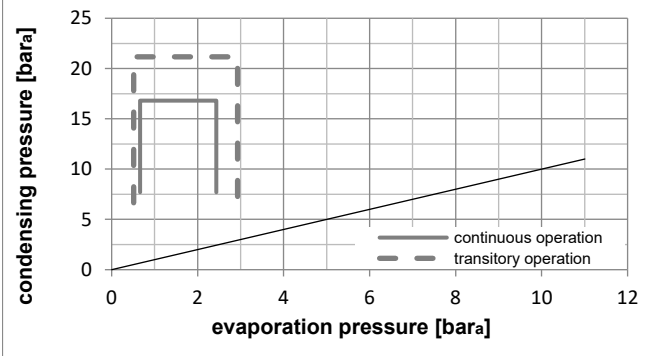
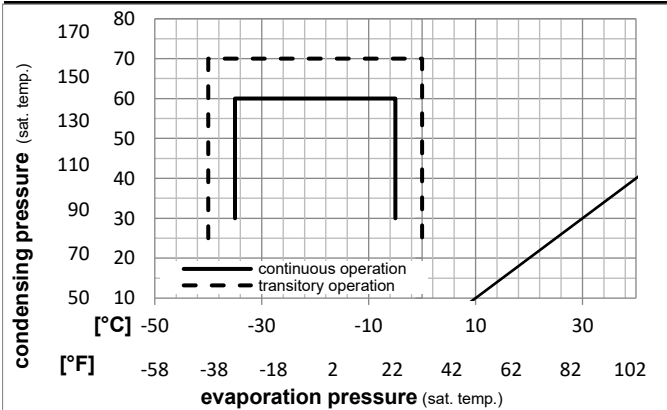

Components

a2	relay	117U6005
c	start capacitor (80μF)	117U5017
d	cord relief	103N1004
b	plastic cover	103N2009

Model

Designation **SC15FT** **220-240V/50Hz** Conf. 1 Sales code: **104G8505**

Optimization + standard conditions

R134a, 220V/50Hz, CSIR, fan 3m/s, CCC, EAC, VDE, KC

	Evaporating pressure (saturation temperature)				Condensing pressure (saturation temperature)			Return gas temp.	Liquid temp.	Cooling capacity	COP	EER	Power consumption			ASHRAE LBP
	pe	pc	RGT	Tliq	[W]	[Btu/h]	[kcal/h]						P1	I	Ref. mass flow	
[°C]																
[°F]																
	-23	54	32	32	384,6	1313	331,0	1,18	4,03	1,02	325,9	2,46	7,47			
	-10	130	90	90												
	-25	55	32	55	280,0	956	241,0	0,90	3,08	0,77	311,0	2,42	6,70			
	-13	131	90	131												
	-35	40	20	40	188,5	644	162,2	0,81	2,77	0,70	232,7	2,23	4,14			
	-31	104	68	104												
	-23	49	4,4	49	319,5	1091	274,9	0,99	3,37	0,85	323,7	2,45	8,44			
	-10	120	40	120												
	-23	41	32	32	431,5	1474	371,3	1,37	4,66	1,17	316,1	2,42	8,38			
	-10	105	90	90												
	-35	45	32	45	172,9	590	148,8	0,75	2,55	0,64	231,4	2,23	3,73			
	-31	113	90	113												

Performance tables

R134a, 220V/50Hz, CSIR, fan 3m/s, CCC, EAC, VDE, KC

	pe		Cooling capacity			COP	EER		P1	I	m
	[°C]	[°F]	[W]	[Btu/h]	[kcal/h]	[W/W]	[Btu/Wh]	[kcal/Wh]	[W]	[A]	[kg/h]
[°C / °F]	-35	-31	172,9	590	148,8	0,75	2,55	0,64	231,4	2,23	3,73
cond. pressure	-30	-22	247,7	846	213,2	0,92	3,14	0,79	269,3	2,31	5,35
pc= 45/113	-25	-13	339,4	1159	292,1	1,10	3,77	0,95	307,8	2,40	7,35
return gas temp.	-23	-10	374,8	1280	322,6	1,17	3,99	1,00	321,1	2,44	8,13
RGT= 32/90	-20	-4	450,3	1538	387,5	1,30	4,43	1,12	347,3	2,51	9,78
liquid temp	-15	5	582,9	1991	501,6	1,50	5,13	1,29	388,0	2,65	12,71
Tliq= 45/113	-5	23	922,4	3150	793,8	1,95	6,65	1,67	474,0	2,98	20,28
[°C / °F]	-35	-31	125,8	430	108,3	0,56	1,93	0,49	222,9	2,22	2,99
cond. pressure	-30	-22	197,3	674	169,8	0,74	2,53	0,64	266,6	2,31	4,70
pc= 55/131	-25	-13	280,0	956	241,0	0,90	3,08	0,77	311,0	2,42	6,70
return gas temp	-23	-10	311,1	1063	267,8	0,95	3,26	0,82	326,3	2,46	7,45
RGT= 32/90	-20	-4	376,5	1286	324,0	1,06	3,61	0,91	356,3	2,54	9,03
liquid temp	-15	5	489,0	1670	420,8	1,21	4,15	1,04	402,8	2,69	11,77
Tliq= 55/131	-5	23	771,7	2635	664,1	1,54	5,27	1,33	500,3	3,05	18,76

Model

Designation	SC15FT	208-230V/60Hz	Conf. 2	Sales code:	104G8505
-------------	---------------	----------------------	----------------	-------------	-----------------

Configuration

Motorconfiguration	CSIR
Power supply (nominal)	208-230V/60Hz 1~
Refrigerant	R134a
Application	LBP
Voltage range	198-254V
Starting torque	HST
Approvals	CCC EAC VDE KC

Electrical accessories / wiring diagram

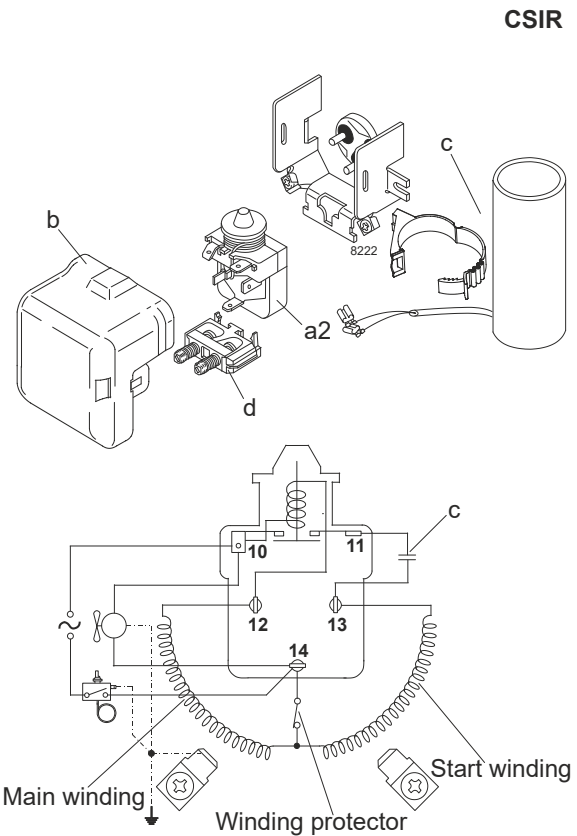

Ambient/ machine room temperatures minimum /maximum

Ambient temperature range:	10 - 43°C / 50 - 110°F
Machine room temperature range:	10 - 48°C / 50 - 119°F
Compressor cooling:	fan 3m/s

Operation Limits

F1 at 43°C ambient temperature possible at 220V nominal (187-242V)

Operation pressure range

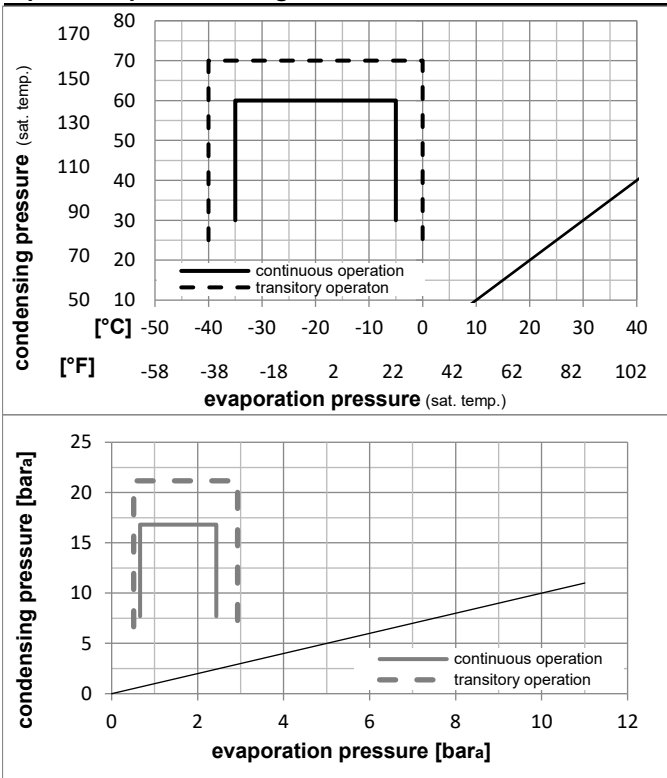

Components

a2	relay	117U6005
c	start capacitor (80μF)	117U5017
d	cord relief	103N1004
b	plastic cover	103N2009

Model

Designation **SC15FT** **208-230V/60Hz** Conf. 2 Sales code: **104G8505**

Optimization + standard conditions

R134a, 220V/60Hz, CSIR, fan 3m/s, CCC, EAC, VDE, KC

		Evaporating pressure (saturation temperature)				Condensing pressure (saturation temperature)					Power consumption				
		Return gas temp.		Liquid temp.		Cooling capacity			COP	EER		Current consumption		Ref. mass flow	
		pe	pc	RGT	Tliq	[W]	[Btu/h]	[kcal/h]	[W/W]	[Btu/Wh]	[kcal/Wh]	P1	I	m	
[°C]	[°F]	[°C]	[°F]	[°C]	[°F]							[W]	[A]	[kg/h]	
-23	-10	54	130	32	90	451,7	1543	388,7	1,20	4,09	1,03	376,9	2,34	8,77	ASHRAE LBP
-25	-13	55	131	32	90	329,5	1125	283,6	0,92	3,16	0,80	356,4	2,27	7,88	cecomaf LBP
-35	-31	40	104	20	68	233,7	798	201,2	0,91	3,11	0,78	256,9	1,96	5,13	EN12900 LBP
-23	-10	49	120	4,4	40	377,7	1290	325,1	1,00	3,43	0,86	376,0	2,33	9,98	ARI540 LBP
-23	-10	41	105	32	90	524,7	1792	451,5	1,41	4,82	1,21	372,1	2,32	10,19	AHAM LBP
-35	-31	45	113	32	90	211,2	721	181,8	0,85	2,89	0,73	249,5	1,94	4,56	opt

Performance tables

R134a, 220V/60Hz, CSIR, fan 3m/s, CCC, EAC, VDE, KC

	pe		Cooling capacity			COP	EER		P1	I	m
	[°C]	[°F]	[W]	[Btu/h]	[kcal/h]	[W/W]	[Btu/Wh]	[kcal/Wh]	[W]	[A]	[kg/h]
[°C / °F]	-35	-31	211,2	721	181,8	0,85	2,89	0,73	249,5	1,94	4,56
cond. pressure	-30	-22	298,4	1019	256,8	0,98	3,36	0,85	303,6	2,10	6,45
pc= 45/113	-25	-13	405,9	1386	349,3	1,14	3,88	0,98	356,9	2,27	8,79
return gas temp.	-23	-10	447,6	1529	385,2	1,19	4,08	1,03	374,9	2,33	9,71
RGT= 32/90	-20	-4	536,8	1833	462,0	1,31	4,48	1,13	409,5	2,45	11,66
liquid temp	-15	5	694,5	2372	597,7	1,51	5,14	1,30	461,4	2,64	15,14
Tliq= 45/113	-5	23	1102,6	3766	948,9	1,96	6,68	1,68	563,4	3,04	24,25
[°C / °F]	-35	-31	153,5	524	132,1	0,66	2,27	0,57	230,9	1,87	3,65
cond. pressure	-30	-22	235,0	802	202,2	0,80	2,73	0,69	294,2	2,07	5,60
pc= 55/131	-25	-13	329,5	1125	283,6	0,92	3,16	0,80	356,4	2,27	7,88
return gas temp	-23	-10	365,3	1247	314,4	0,97	3,31	0,83	377,3	2,34	8,74
RGT= 32/90	-20	-4	440,5	1504	379,1	1,05	3,60	0,91	417,6	2,48	10,57
liquid temp	-15	5	571,0	1950	491,4	1,19	4,08	1,03	477,9	2,70	13,75
Tliq= 55/131	-5	23	903,6	3086	777,7	1,52	5,18	1,30	596,0	3,16	21,97

Model

Designation	SC15FT	220-240V/50Hz	Conf. 3	Sales code:	104G8505
-------------	---------------	----------------------	----------------	-------------	-----------------

Configuration

Motorconfiguration	RSIR
Power supply (nominal)	220-240V/50Hz 1~
Refrigerant	R134a
Application	LBP
Voltage range	187-254V
Starting torque	LST
Approvals	CCC EAC VDE KC

Electrical accessories / wiring diagram

RSIR

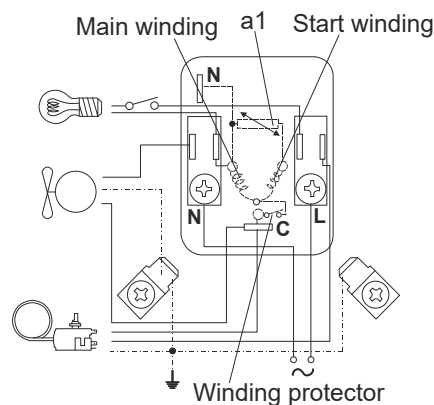
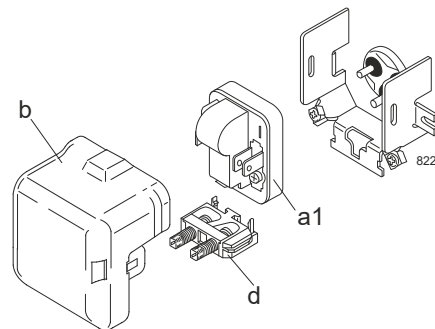

Ambient/ machine room temperatures minimum /maximum

Ambient temperature range: 10 - 43°C / 50 - 110°F

Machine room temperature range: 10 - 48°C / 50 - 119°F

Compressor cooling: fan 3m/s

Operation Limits

F1 at 43°C ambient temperature possible at 220V nominal (187-242V)

Operation pressure range

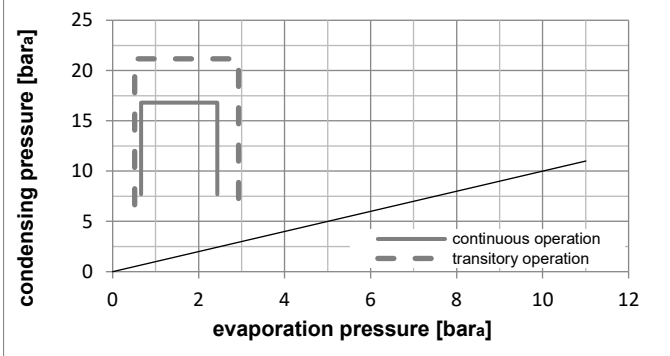
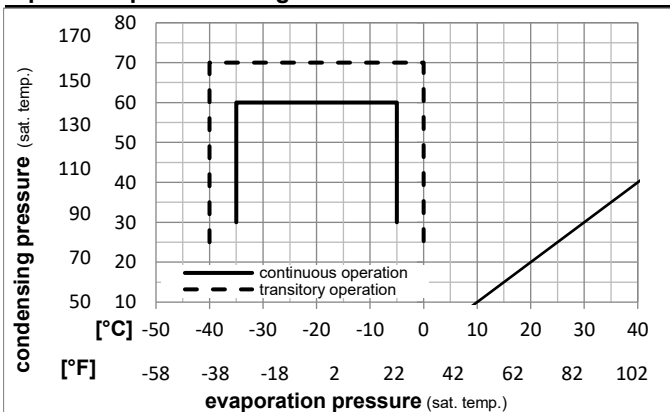

Components

a1	PTC starter (220V, 25Ohm, 6.3mm)	103N0011
d	cord relief	103N1004
b	plastic cover	103N2009

Model

Designation **SC15FT** **220-240V/50Hz** Conf. 3 Sales code: **104G8505**

Optimization + standard conditions

R134a, 220V/50Hz, RSIR, fan 3m/s, CCC, EAC, VDE, KC

		Evaporating pressure (saturation temperature)				Condensing pressure (saturation temperature)						Power consumption			
		Return gas temp.		Liquid temp.		Cooling capacity		COP	EER		Current consumption		Ref. mass flow		
		pe	pc	RGT	Tliq	[W]	[Btu/h]	[kcal/h]	[W/W]	[Btu/Wh]	[kcal/Wh]	P1	I	m	
[°C]	[°F]	[°C]	[°F]	[°C]	[°F]							[W]	[A]	[kg/h]	
[°C]	-23	54	32	32	384,6	1313	331,0	1,18	4,03	1,02	325,9	2,46	7,47	ASHRAE LBP	
[°F]	-10	130	90	90											
[°C]	-25	55	32	55	280,0	956	241,0	0,90	3,08	0,77	311,0	2,42	6,70	cecomaf LBP	
[°F]	-13	131	90	131											
[°C]	-35	40	20	40	188,5	644	162,2	0,81	2,77	0,70	232,7	2,23	4,14	EN12900 LBP	
[°F]	-31	104	68	104											
[°C]	-23	49	4,4	49	319,5	1091	274,9	0,99	3,37	0,85	323,7	2,45	8,44	ARI540 LBP	
[°F]	-10	120	40	120											
[°C]	-23	41	32	32	431,5	1474	371,3	1,37	4,66	1,17	316,1	2,42	8,38	AHAM LBP	
[°F]	-10	105	90	90											
[°C]	-35	45	32	45	172,9	590	148,8	0,75	2,55	0,64	231,4	2,23	3,73	opt	
[°F]	-31	113	90	113											

Performance tables

R134a, 220V/50Hz, RSIR, fan 3m/s, CCC, EAC, VDE, KC

	pe		Cooling capacity			COP	EER		P1	I	m
	[°C]	[°F]	[W]	[Btu/h]	[kcal/h]	[W/W]	[Btu/Wh]	[kcal/Wh]	[W]	[A]	[kg/h]
[°C / °F]	-35	-31	172,9	590	148,8	0,75	2,55	0,64	231,4	2,23	3,73
cond. pressure	-30	-22	247,7	846	213,2	0,92	3,14	0,79	269,3	2,31	5,35
pc= 45/113	-25	-13	339,4	1159	292,1	1,10	3,77	0,95	307,8	2,40	7,35
return gas temp.	-23	-10	374,8	1280	322,6	1,17	3,99	1,00	321,1	2,44	8,13
RGT= 32/90	-20	-4	450,3	1538	387,5	1,30	4,43	1,12	347,3	2,51	9,78
liquid temp	-15	5	582,9	1991	501,6	1,50	5,13	1,29	388,0	2,65	12,71
Tliq= 45/113	-5	23	922,4	3150	793,8	1,95	6,65	1,67	474,0	2,98	20,28
[°C / °F]	-35	-31	125,8	430	108,3	0,56	1,93	0,49	222,9	2,22	2,99
cond. pressure	-30	-22	197,3	674	169,8	0,74	2,53	0,64	266,6	2,31	4,70
pc= 55/131	-25	-13	280,0	956	241,0	0,90	3,08	0,77	311,0	2,42	6,70
return gas temp	-23	-10	311,1	1063	267,8	0,95	3,26	0,82	326,3	2,46	7,45
RGT= 32/90	-20	-4	376,5	1286	324,0	1,06	3,61	0,91	356,3	2,54	9,03
liquid temp	-15	5	489,0	1670	420,8	1,21	4,15	1,04	402,8	2,69	11,77
Tliq= 55/131	-5	23	771,7	2635	664,1	1,54	5,27	1,33	500,3	3,05	18,76

Model

Designation	SC15FT	208-230V/60Hz	Conf. 4	Sales code:	104G8505
-------------	---------------	----------------------	----------------	-------------	-----------------

Configuration

Motorconfiguration	RSIR
Power supply (nominal)	208-230V/60Hz 1~
Refrigerant	R134a
Application	LBP
Voltage range	198-254V
Starting torque	LST
Approvals	CCC EAC VDE KC

Electrical accessories / wiring diagram

RSIR

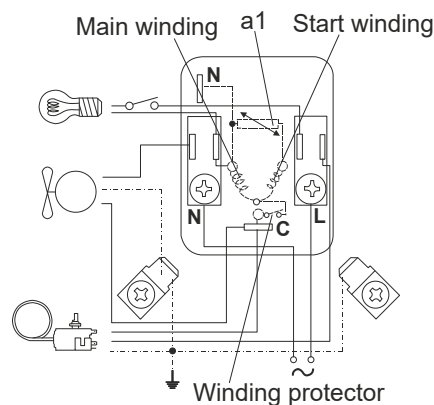
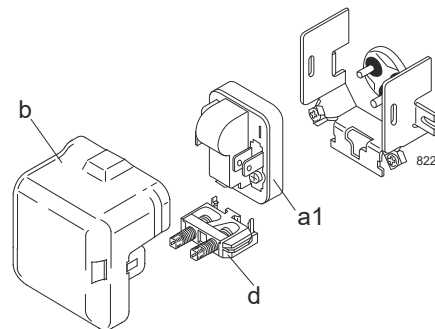

Ambient/ machine room temperatures minimum /maximum

Ambient temperature range: 10 - 43°C / 50 - 110°F

Machine room temperature range: 10 - 48°C / 50 - 119°F

Compressor cooling: fan 3m/s

Operation Limits

F1 at 43°C ambient temperature possible at 220V nominal (187-242V)

Operation pressure range

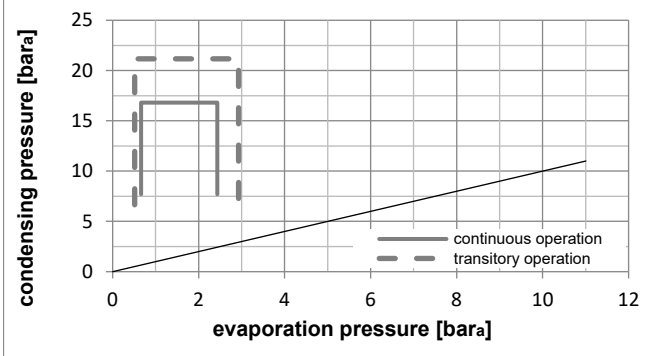
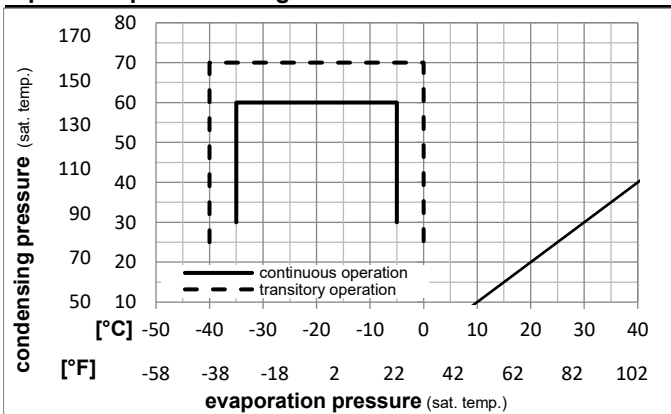

Components

a1	PTC starter (220V, 25Ohm, 6.3mm)	103N0011
d	cord relief	103N1004
b	plastic cover	103N2009

Model

Designation **SC15FT** **208-230V/60Hz** Conf. 4 Sales code: **104G8505**

Optimization + standard conditions

R134a, 220V/60Hz, RSIR, fan 3m/s, CCC, EAC, VDE, KC

		Evaporating pressure (saturation temperature)				Condensing pressure (saturation temperature)					Power consumption				
		Return gas temp.			Liquid temp.		Cooling capacity			COP	EER	Current consumption		Ref. mass flow	
		pe	pc	RGT	Tliq	[W]	[Btu/h]	[kcal/h]	[W/W]	[Btu/Wh]	[kcal/Wh]	P1	I	m	
[°C]	[°F]	[°C]	[°F]	[°C]	[°C]							[W]	[A]	[kg/h]	
-23	54	32	32	451,7	1543	388,7	1,20	4,09	1,03	376,9	2,34	8,77	ASHRAE LBP		
-10	130	90	90												
-25	55	32	55	329,5	1125	283,6	0,92	3,16	0,80	356,4	2,27	7,88	cecomaf LBP		
-13	131	90	131												
-35	40	20	40	233,7	798	201,2	0,91	3,11	0,78	256,9	1,96	5,13	EN12900 LBP		
-31	104	68	104												
-23	49	4,4	49	377,7	1290	325,1	1,00	3,43	0,86	376,0	2,33	9,98	ARI540 LBP		
-10	120	40	120												
-23	41	32	32	524,7	1792	451,5	1,41	4,82	1,21	372,1	2,32	10,19	AHAM LBP		
-10	105	90	90												
-35	45	32	45	211,2	721	181,8	0,85	2,89	0,73	249,5	1,94	4,56	opt		
-31	113	90	113												

Performance tables

R134a, 220V/60Hz, RSIR, fan 3m/s, CCC, EAC, VDE, KC

	pe		Cooling capacity			COP	EER	P1	I	m	
	[°C]	[°F]	[W]	[Btu/h]	[kcal/h]	[W/W]	[Btu/Wh]	[kcal/Wh]	[W]	[A]	[kg/h]
[°C / °F]	-35	-31	211,2	721	181,8	0,85	2,89	0,73	249,5	1,94	4,56
cond. pressure	-30	-22	298,4	1019	256,8	0,98	3,36	0,85	303,6	2,10	6,45
pc= 45/113	-25	-13	405,9	1386	349,3	1,14	3,88	0,98	356,9	2,27	8,79
return gas temp.	-23	-10	447,6	1529	385,2	1,19	4,08	1,03	374,9	2,33	9,71
RGT= 32/90	-20	-4	536,8	1833	462,0	1,31	4,48	1,13	409,5	2,45	11,66
liquid temp	-15	5	694,5	2372	597,7	1,51	5,14	1,30	461,4	2,64	15,14
Tliq= 45/113	-5	23	1102,6	3766	948,9	1,96	6,68	1,68	563,4	3,04	24,25
[°C / °F]	-35	-31	153,5	524	132,1	0,66	2,27	0,57	230,9	1,87	3,65
cond. pressure	-30	-22	235,0	802	202,2	0,80	2,73	0,69	294,2	2,07	5,60
pc= 55/131	-25	-13	329,5	1125	283,6	0,92	3,16	0,80	356,4	2,27	7,88
return gas temp	-23	-10	365,3	1247	314,4	0,97	3,31	0,83	377,3	2,34	8,74
RGT= 32/90	-20	-4	440,5	1504	379,1	1,05	3,60	0,91	417,6	2,48	10,57
liquid temp	-15	5	571,0	1950	491,4	1,19	4,08	1,03	477,9	2,70	13,75
Tliq= 55/131	-5	23	903,6	3086	777,7	1,52	5,18	1,30	596,0	3,16	21,97



SC Compressors

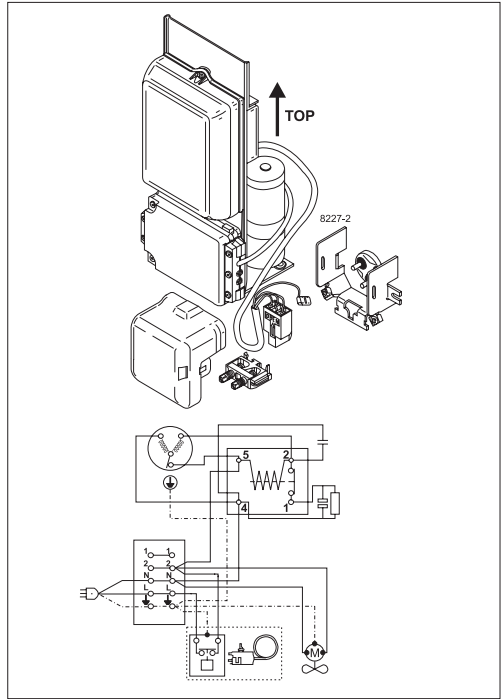



SC Compressors

Service/Repair – R290



8545



Secop accepts no responsibility for possible errors in catalogs, brochures, and other printed material. Secop reserves the right to alter its products without notice. This also applies to products already on order provided that such alterations can be made without subsequent changes being necessary to specifications already agreed. All trademarks in this material are the property of the respective companies. Secop and the Secop logotype are trademarks of Secop GmbH. All rights reserved. www.secop.com