

Single Pack NL10FT 220-240V 50Hz CSIR

Single pack code number: **195B4100**

Position	Title	Code	Amount
1	Compressor NL10FT	105G6829	1
2	Starting relay	117U6002	1
3	Starting capacitor (80 μ F 220V, 6.3mm)	117U5015	1
4	Cord relief	103N1010	1
5	Cover	103N2010	1
6	Bolt joint for one compressor M6 \varnothing 16mm	118-1917	1

Secop GmbH • Lise-Meitner-Straße 29 • 24941 Flensburg, Germany • Tel: +49 461 4941 0 • www.secop.com

Secop accepts no responsibility for possible errors in catalogs, brochures, and other printed material. Secop reserves the right to alter its products without notice. This also applies to products already on order provided that such alterations can be made without subsequent changes being necessary to specifications already agreed. All trademarks in this material are the property of the respective companies. Secop and the Secop logotype are trademarks of Secop GmbH. All rights reserved.

Model

Designation	NL10FT	220-240V/50Hz 1~	Sales code:	105G6829
-------------	---------------	-------------------------	-------------	-----------------

Compressor design

Oil type	Polyolester	Refrigerant(s)	R134a
Oil viscosity	32cST	Displacement	10,09cm ³ / 0,62cu.in
Oil quantity	300cm ³ / 10,1fl.oz	Compressors on pallet	80
Refr. charge - tech. limit	400g / 14,1oz		
Free gas volume comp.	2360cm ³ / 79,8fl.oz		
Weight	10,5kg / 23,1lbs		
Motor protection	1# internal		
Winding resistance main	8,7Ω (at 25°C)		
Winding resistance aux	13,8Ω (at 25°C)		
Max. winding temp.	125°C / 257°F		
Max. discharge temp.	130°C / 266°F		



General - Configurations with NL10FT

	Conf. 1	Conf. 2
Motorconfiguration	RSIR	CSIR
Power supply (nominal)	220-240V/50Hz	220-240V/50Hz
Number of phases	1	1
Voltage range	187-254V	187-254V
Approvals	VDE, CCC, EAC	VDE, CCC, EAC
Starting torque	LST	HST
Note	- / -	

Applications with NL10FT

	Conf. 1	Conf. 2
Refrigerant	R134a	R134a
Application	LBP	LBP
System cooling	static	static
Hot gas defrost	- / -	- / -
Long interval pull down	- / -	- / -

Electrical data - Configurations with NL10FT

	Conf. 1	Conf. 2
Starting device type	PTC	relay
Run capacitor	- / -	- / -
Start capacitor	- / -	80μF
LRA (locked rotor amps / 4s)	9,2A	10,4A
RLA (rated load amps / 1s)	1,8A	1,8A
Cut in current	13,6A	10,4A

Model

Designation	NL10FT	220-240V/50Hz 1~	Sales code:	105G6829
-------------	---------------	-------------------------	-------------	-----------------

Compressor dimensions

Housing	A Height	203mm / 7,99in
	B Height	197mm / 7,76in
	C Length shell	205mm / 8,07in
	D Length w. cover	254mm / 10in
	E Width	166mm / 6,54in

Connectors		Suction	Discharge	Process
		X	Y	Z
Diameter	[mm]	øi 8,11-8,29	øi 6,11-6,29	øi 6,11-6,29
(i:inside, o:outside)	[in]	øi 0,32-0,33	øi 0,24-0,25	øi 0,24-0,25
Material		copper	copper	copper
Horizontal angle	±2°	0°	0°	0°
Vertical angle	±2°	15°	35°	155°
Position l/h/w	[mm]	126/76/78	133/103/54	-107/94/72
	[in]	4,9/3/3,1	5,2/4/2,1	-4,2/3,7/2,8
Straight tube l.	[mm]	12	12	12
	[in]	0,5	0,5	0,5

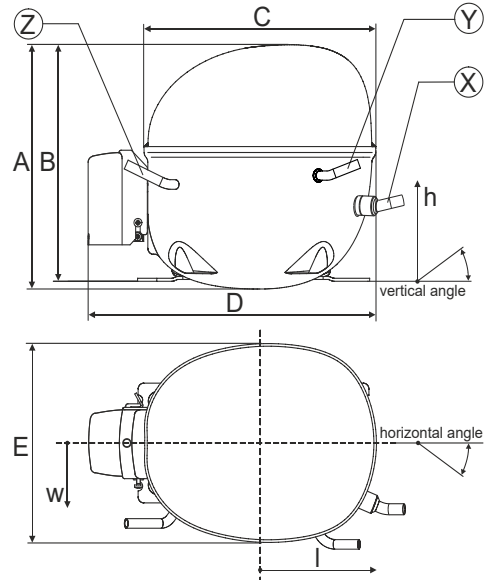

Compressor fixation

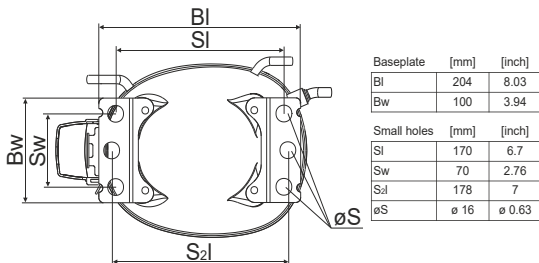

Bolt joint

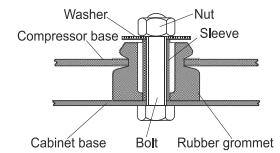

Snap-on

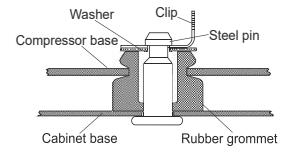

Mounting accessories	one comp.	multi pack
Bolt joint M6 ø16mm	118-1917	118-1918
Bolt joint ø1/4" ø16mm	118-1946	
Bolt joint ø1/4" ø19mm	118-1949	
Snap-on ø7,3 ø16mm	118-1947	118-1919

Model

Designation	NL10FT	220-240V/50Hz	Conf. 1	Sales code:	105G6829
-------------	---------------	----------------------	----------------	-------------	-----------------

Configuration

Motorconfiguration	RSIR
Power supply (nominal)	220-240V/50Hz 1~
Refrigerant	R134a
Application	LBP
Voltage range	187-254V
Starting torque	LST
Approvals	VDE CCC EAC

Electrical accessories / wiring diagram

RSIR

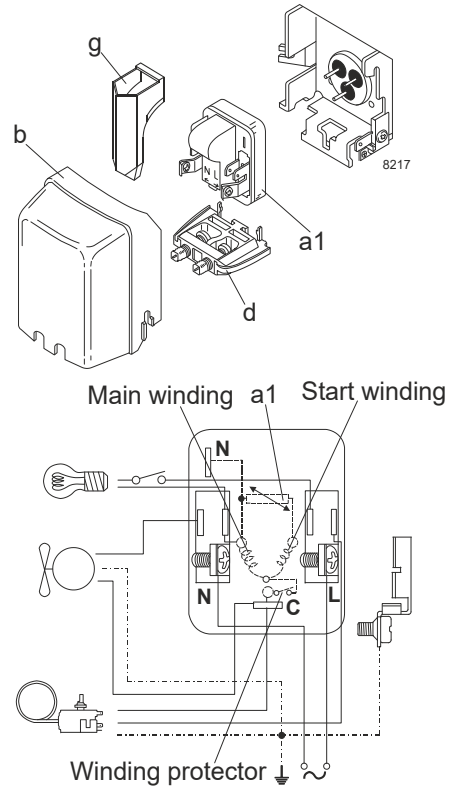

Ambient temperatures / system cooling

Ambient temperature min.:	10°C / 50°F
Ambient temperature max.:	43°C / 110°F

System cooling (n/a: outside limits)			
T ambient	LBP	MBP	HBP
32°C / 90°F	static	n/a	n/a
38°C / 100°F	fan 1,5m/s	n/a	n/a
43°C / 110°F	fan 3m/s	n/a	n/a

Operation pressure range

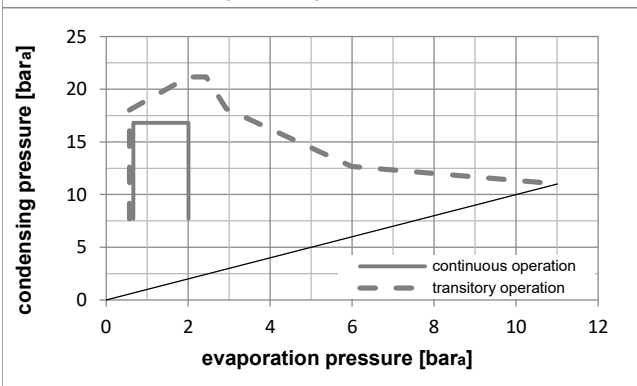
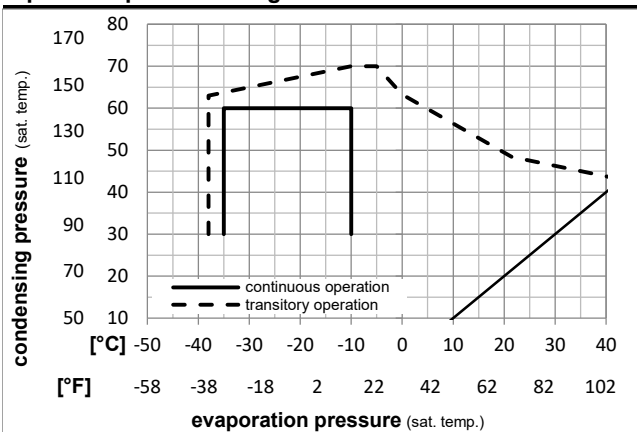

Components

a1	PTC starter (220V, 250hm, 4.8mm)	103N0018
b	plastic cover	103N2010
d	cord relief	103N1010
g	protection screen for PTC	103N0476

Alternative components

a1	PTC starter (220V, 250hm, 6.3mm)	103N0011
b	plastic cover	103N2011
d	cord relief	103N1010
g	protection screen for PTC	103N0476

Model

Designation	NL10FT	220-240V/50Hz	Conf. 1	Sales code:	105G6829
-------------	---------------	----------------------	----------------	-------------	-----------------

Optimization + standard conditions

R134a, 220V/50Hz, RSIR, static, VDE, CCC, EAC

Evaporating pressure (saturation temperature)		Condensing pressure (saturation temperature)				Cooling capacity			COP	EER	Power consumption			ASHRAE LBP
		Return gas temp.				Liquid temp.					Current consumption		Ref. mass flow	
pe	pc	RGT	Tliq							P1	I	m		
[°C]	[°F]	[°C]	[°C]	[°C]	[W]	[Btu/h]	[kcal/h]	[W/W]	[Btu/Wh]	[kcal/Wh]	[W]	[A]	[kg/h]	
-23,3	54,4	32,2	32,2		283,8	969	244,2	1,25	4,27	1,08	227,0	1,54	5,51	ASHRAE LBP
-10	130	90	90											
-25	55	32	55		210,3	718	181,0	0,98	3,34	0,84	215,1	1,50	5,03	cecomaf LBP
-13	131	89,6	131											
-35	40	20	40		152,2	520	131,0	0,95	3,26	0,82	159,4	1,36	3,34	EN12900 LBP
-31	104	68	104											
-23,3	48,9	4,44	48,9		230,8	788	198,6	1,01	3,46	0,87	227,9	1,55	6,10	ARI540 LBP
-10	120	40	120											
-23,3	40,6	32,2	32,2		313,4	1070	269,7	1,44	4,91	1,24	217,9	1,52	6,08	AHAM LBP
-10	105	90	90											
-35	45	32	45		141,9	484	122,1	0,88	3,00	0,76	161,5	1,36	3,06	opt
-31	113	89,6	113											

Performance tables

R134a, 220V/50Hz, RSIR, static, VDE, CCC, EAC

pe	Cooling capacity			COP			EER			P1	I	m
	[°C]	[°F]	[W]	[Btu/h]	[kcal/h]	[W/W]	[Btu/Wh]	[kcal/Wh]				
[°C / °F]	-35	-31	141,9	484	122,1	0,88	3,00	0,76	161,5	1,36	3,06	
cond. pressure	-30	-22	189,6	648	163,2	1,03	3,51	0,88	184,6	1,42	4,10	
pc= 45/113	-25	-13	248,7	849	214,0	1,16	3,98	1,00	213,5	1,50	5,39	
return gas temp.	-23,3	-10	271,6	928	233,7	1,21	4,14	1,04	224,2	1,54	5,89	
RGT= 32/90	-20	-4	320,6	1095	275,9	1,31	4,46	1,12	245,4	1,61	6,97	
liquid temp	-15	5	407,2	1391	350,4	1,47	5,01	1,26	277,5	1,72	8,88	
Tliq= 45/113	-10	14	510,1	1742	439,0	1,66	5,68	1,43	306,8	1,83	11,16	
[°C / °F]	-35	-31	114,8	392	98,8	0,72	2,47	0,62	158,9	1,35	2,73	
cond. pressure	-30	-22	157,7	538	135,7	0,86	2,93	0,74	183,9	1,41	3,76	
pc= 55/131	-25	-13	210,3	718	181,0	0,98	3,34	0,84	215,1	1,50	5,03	
return gas temp	-23,3	-10	230,8	788	198,6	1,02	3,48	0,88	226,5	1,54	5,52	
RGT= 32/90	-20	-4	274,5	937	236,2	1,10	3,76	0,95	249,4	1,62	6,58	
liquid temp	-15	5	351,7	1201	302,7	1,24	4,23	1,07	284,2	1,74	8,47	
Tliq= 55/131	-10	14	443,7	1515	381,9	1,40	4,79	1,21	316,4	1,87	10,73	

Model

Designation	NL10FT	220-240V/50Hz	Conf. 2	Sales code:	105G6829
-------------	---------------	----------------------	----------------	-------------	-----------------

Configuration

Motorconfiguration	CSIR
Power supply (nominal)	220-240V/50Hz 1~
Refrigerant	R134a
Application	LBP
Voltage range	187-254V
Starting torque	HST
Approvals	VDE CCC EAC

Electrical accessories / wiring diagram

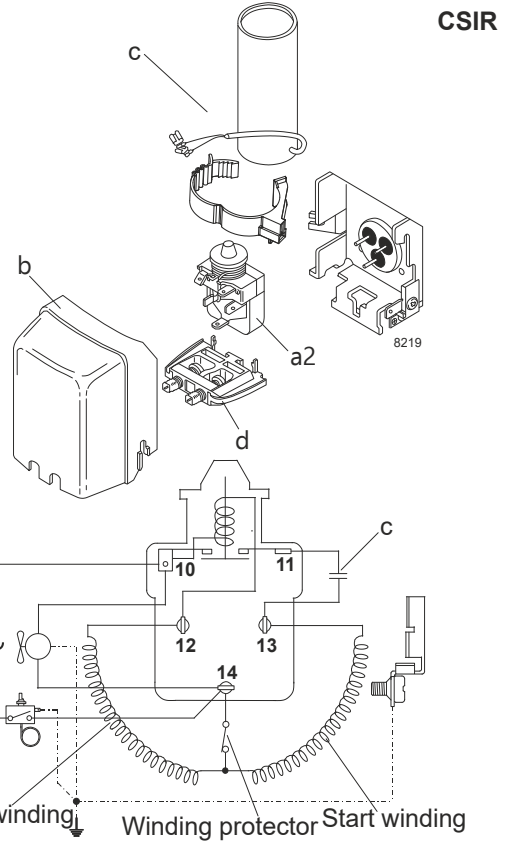

Ambient temperatures / system cooling

Ambient temperature min.:	10°C / 50°F
Ambient temperature max.:	43°C / 110°F

System cooling (n/a: outside limits)			
T ambient	LBP	MBP	HBP
32°C / 90°F	static	n/a	n/a
38°C / 100°F	fan 1,5m/s	n/a	n/a
43°C / 110°F	fan 3m/s	n/a	n/a

Operation pressure range

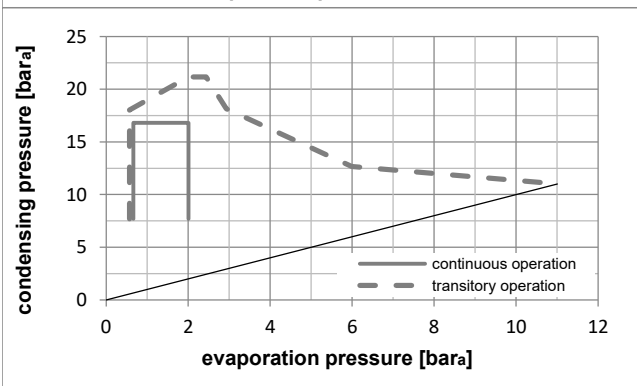
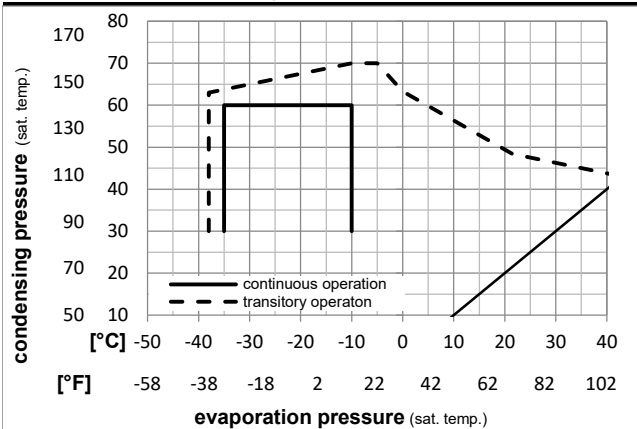

Components

a2	assy. relay	117U6002
c	start capacitor (80µF)	117U5015
b	plastic cover	103N2010
d	cord relief	103N1010

Alternative components

b	plastic cover	103N2011
---	---------------	----------

Model

Designation	NL10FT	220-240V/50Hz	Conf. 2	Sales code:	105G6829
-------------	---------------	----------------------	----------------	-------------	-----------------

Optimization + standard conditions

R134a, 220V/50Hz, CSIR, static, VDE, CCC, EAC

		Evaporating pressure (saturation temperature)				Condensing pressure (saturation temperature)						Power consumption							
						Return gas temp.						Current consumption							
						Liquid temp.						Ref. mass flow							
						Cooling capacity						COP			EER	P1	I	m	
		pe	pc	RGT	Tliq	[W]	[Btu/h]	[kcal/h]	[W/W]	[Btu/Wh]	[kcal/Wh]	[W]	[A]	[kg/h]					
[°C]	-23	54,4	32,2	32,2	283,8	969	244,2	1,25	4,27	1,08	227,0	1,54	5,51	ASHRAE LBP					
[°F]	-10	130	90	90															
[°C]	-25	55	32	55	210,3	718	181,0	0,98	3,34	0,84	215,1	1,50	5,03	cecomaf LBP					
[°F]	-13	131	89,6	131															
[°C]	-35	40	20	40	152,2	520	131,0	0,95	3,26	0,82	159,4	1,36	3,34	EN12900 LBP					
[°F]	-31	104	68	104															
[°C]	-23	48,9	4,44	48,9	230,8	788	198,6	1,01	3,46	0,87	227,9	1,55	6,10	ARI540 LBP					
[°F]	-10	120	40	120															
[°C]	-23	40,6	32,2	32,2	313,4	1070	269,7	1,44	4,91	1,24	217,9	1,52	6,08	AHAM LBP					
[°F]	-10	105	90	90															
[°C]	-35	45	32	45	141,9	484	122,1	0,88	3,00	0,76	161,5	1,36	3,06	opt					
[°F]	-31	113	89,6	113															

Performance tables

R134a, 220V/50Hz, CSIR, static, VDE, CCC, EAC

	pe		Cooling capacity			COP			EER			P1	I	m
	[°C]	[°F]	[W]	[Btu/h]	[kcal/h]	[W/W]	[Btu/Wh]	[kcal/Wh]	[W]	[A]	[kg/h]			
[°C / °F]	-35	-31	141,9	484	122,1	0,88	3,00	0,76	161,5	1,36	3,06			
cond. pressure	-30	-22	189,6	648	163,2	1,03	3,51	0,88	184,6	1,42	4,10			
pc= 45/113	-25	-13	248,7	849	214,0	1,16	3,98	1,00	213,5	1,50	5,39			
return gas temp.	-23	-10	271,6	928	233,7	1,21	4,14	1,04	224,2	1,54	5,89			
RGT= 32/90	-20	-4	320,6	1095	275,9	1,31	4,46	1,12	245,4	1,61	6,97			
liquid temp	-15	5	407,2	1391	350,4	1,47	5,01	1,26	277,5	1,72	8,88			
Tliq= 45/113	-10	14	510,1	1742	439,0	1,66	5,68	1,43	306,8	1,83	11,16			
[°C / °F]	-35	-31	114,8	392	98,8	0,72	2,47	0,62	158,9	1,35	2,73			
cond. pressure	-30	-22	157,7	538	135,7	0,86	2,93	0,74	183,9	1,41	3,76			
pc= 55/131	-25	-13	210,3	718	181,0	0,98	3,34	0,84	215,1	1,50	5,03			
return gas temp	-23	-10	230,8	788	198,6	1,02	3,48	0,88	226,5	1,54	5,52			
RGT= 32/90	-20	-4	274,5	937	236,2	1,10	3,76	0,95	249,4	1,62	6,58			
liquid temp	-15	5	351,7	1201	302,7	1,24	4,23	1,07	284,2	1,74	8,47			
Tliq= 55/131	-10	14	443,7	1515	381,9	1,40	4,79	1,21	316,4	1,87	10,73			



NL Compressors





Service/Repair – R600a, R290

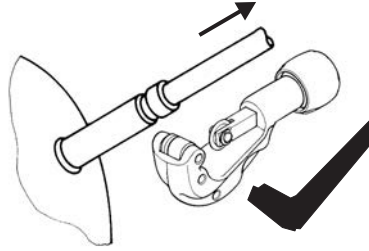

8545

Brazing on Suction Connectors (Direct Intake)

representative image



**! max. 150°C/302°F !
at socket**
brazing solder: phosphor (LP7) or silver

Refer to Product Bulletin:
**Brazing on Suction Connectors
(Compressors with Direct Suction Intake)**

Secop accepts no responsibility for possible errors in catalogs, brochures, and other printed material. Secop reserves the right to alter its products without notice. This also applies to products already on order provided that such alterations can be made without subsequential changes being necessary to specifications already agreed. All trademarks in this material are the property of the respective companies. Secop and the Secop logotype are trademarks of Secop GmbH. All rights reserved. www.secop.com