

Single Pack NLE8.8CN 220-240V 50Hz CSIR

Single pack code number: **195B4103**

Position	Title	Code	Amount
1	Compressor NLE8.8CN	105H6880	1
2	Starting relay	117U7002	1
3	Starting capacitor (80 μ F 220V, 6.3mm)	117U5015	1
4	Cord relief	103N1010	1
5	Cover	103N2010	1
6	Bolt joint for one compressor M6 \varnothing 16mm	118-1917	1

Secop GmbH • Lise-Meitner-Straße 29 • 24941 Flensburg, Germany • Tel: +49 461 4941 0 • www.secop.com

Secop accepts no responsibility for possible errors in catalogs, brochures, and other printed material. Secop reserves the right to alter its products without notice. This also applies to products already on order provided that such alterations can be made without subsequent changes being necessary to specifications already agreed. All trademarks in this material are the property of the respective companies. Secop and the Secop logotype are trademarks of Secop GmbH. All rights reserved.

Model

Designation	NLE8.8CN	220-240V/50Hz 1~	Sales code:	105H6880
-------------	-----------------	------------------	-------------	-----------------

Compressor design

Oil type	Polyolester	Refrigerant(s)	R290
Oil viscosity	19,2cST	Displacement	8,76cm ³ / 0,53cu.in
Oil quantity	265cm ³ / 9fl.oz	Compressors on pallet	80
Refr. charge - tech. limit	400g / 14,1oz		
Free gas volume comp.	2360cm ³ / 79,8fl.oz		
Weight	10,9kg / 24lbs		
Motor protection	1# internal		
Winding resistance main	9,28Ω (at 25°C)		
Winding resistance aux	11,64Ω (at 25°C)		
Max. winding temp.	125°C / 257°F		
Max. discharge temp.	120°C / 248°F		



General - Configurations with NLE8.8CN

	Conf. 1	Conf. 2	Conf. 3
Motorconfiguration	CSIR	RSIR	RSCR
Power supply (nominal)	220-240V/50Hz	220-240V/50Hz	220-240V/50Hz
Number of phases	1	1	1
Voltage range	198-254V	198-254V	198-254V
Approvals	VDE, CCC	VDE, CCC	VDE, CCC
Starting torque	HST	LST	LST
Note	- / -		

Applications with NLE8.8CN

	Conf. 1	Conf. 2	Conf. 3
Refrigerant	R290	R290	R290
Application	LBP+MBP	LBP+MBP	LBP+MBP
System cooling	fan 3m/s	fan 3m/s	fan 3m/s
Hot gas defrost	OK	OK	OK
Long interval pull down	OK	OK	OK

Electrical data - Configurations with NLE8.8CN

	Conf. 1	Conf. 2	Conf. 3
Starting device type	relay	PTC	PTC
Run capacitor	-/-	-/-	4μF
Start capacitor	80μF	-/-	-/-
LRA (locked rotor amps / 4s)	11,3A	10,7A	10,1A
RLA (rated load amps / 1s)	2,15A	2,15A	2,05A
Cut in current	11,3A	15,9A	15,9A

Model

Designation

NLE8.8CN

220-240V/50Hz 1~

Sales code:

105H6880

Compressor dimensions

Housing	A Height	203mm / 7,99in
	B Height	197mm / 7,76in
	C Length shell	205mm / 8,07in
	D Length w. cover	254mm / 10in
	E Width	166mm / 6,54in

Connectors		Suction	Discharge	Process
		X	Y	Z
Diameter	[mm]	øi 8,11-8,29	øi 6,11-6,29	øi 6,11-6,29
	(i:inside, o:outside) [in]	øi 0,32-0,33	øi 0,24-0,25	øi 0,24-0,25
Material		copper	copper	copper
Horizontal angle	±2°	0°	0°	0°
Vertical angle	±2°	15°	21°	155°
Position l/h/w	[mm]	132/69/57	94/102/81	-109/94/72
	[in]	5,2/2,7/2,2	3,7/4/3,2	-4,3/3,7/2,8
Straight tube l.	[mm]	12	12	12
	[in]	0,5	0,5	0,5

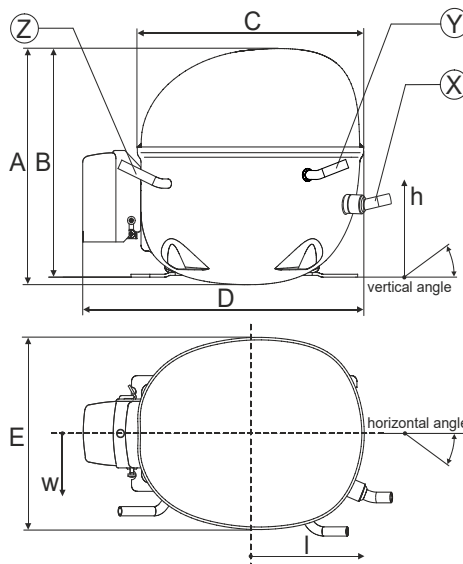

Compressor fixation

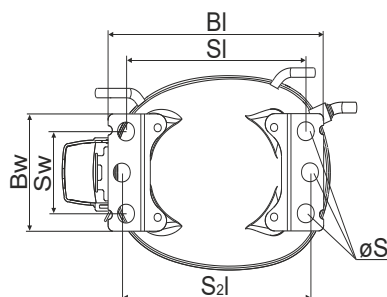

Baseplate	[mm]	[inch]
BI	204	8.03
BW	100	3.94

Small holes	[mm]	[inch]
SI	170	6.7
SW	70	2.76
S2l	178	7
øS	ø 16	ø 0.63

Bolt joint



Snap-on



Mounting accessories

	one comp.	multi pack
Bolt joint M6 ø16mm	118-1917	118-1918
Bolt joint ø1/4" ø16mm	118-1946	
Snap-on ø7,3 ø16mm	118-1947	118-1919

Application notes

Provision for PE Grounding is located at the PE Stamp on the compressor

Model

Designation	NLE8.8CN	220-240V/50Hz	Conf. 1	Sales code:	105H6880
-------------	-----------------	----------------------	---------	-------------	-----------------

Configuration

Motorconfiguration	CSIR
Power supply (nominal)	220-240V/50Hz 1~
Refrigerant	R290
Application	LBP+MBP
Voltage range	198-254V
Starting torque	HST
Approvals	VDE
	CCC

Electrical accessories / wiring diagram

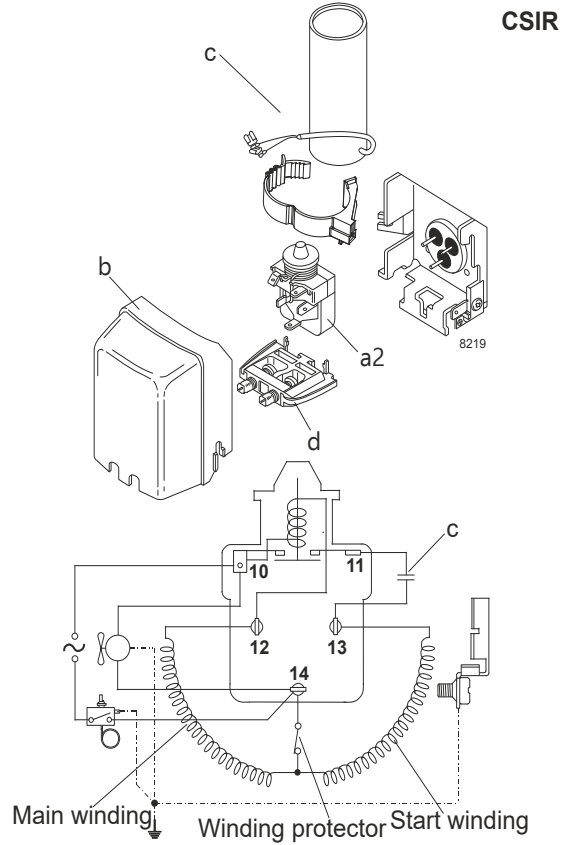

Ambient/ machine room temperatures minimum /maximum

Ambient temperature range:	10 - 43°C / 50 - 110°F
Machine room temperature range:	10 - 48°C / 50 - 119°F
Compressor cooling:	fan 3m/s

Operation pressure range

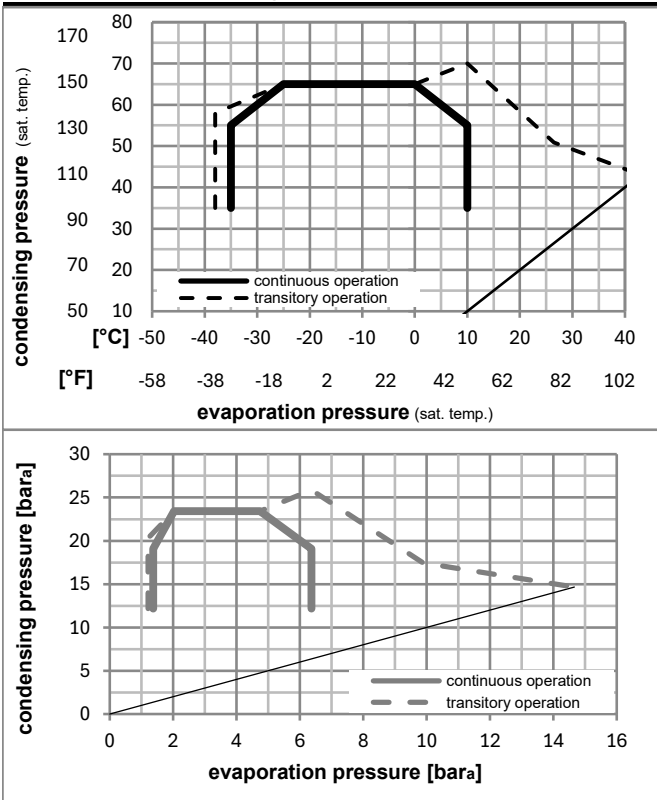

Components

a2	relay	117U7002
c	start capacitor (80µF)	117U5015
b	plastic cover	103N2010
d	cord relief	103N1010

Alternative components

c	start capacitor (80µF)	117U5079
b	plastic cover	103N2011

Model

Designation	NLE8.8CN	220-240V/50Hz	Conf. 1	Sales code:	105H6880
-------------	-----------------	----------------------	----------------	-------------	-----------------

Optimization + standard conditions

R290, 220V/50Hz, CSIR, fan 3m/s, VDE, CCC

	Evaporating pressure (saturation temperature)				Cooling capacity			COP	EER	P1	Power consumption		ASHRAE LBP	
	pe	pc	RGT	Tliq	[W]	[Btu/h]	[kcal/h]				I	m		
	[°C]	[°F]	[°C]	[°F]	[W]	[Btu/h]	[kcal/h]	[W/W]	[Btu/Wh]	[kcal/Wh]	[W]	[A]	[kg/h]	
	-23	54	32	32	429,7	1468	369,8	1,56	5,34	1,35	274,9	1,76	4,35	
	-10	130	90	90										
	-25	55	32	55	321,7	1099	276,9	1,22	4,16	1,05	264,4	1,73	4,01	cecomaf LBP
	-13	131	90	131										
	-35	40	20	40	255,5	873	219,9	1,26	4,30	1,08	203,2	1,55	2,92	EN12900 LBP
	-31	104	68	104										
	-7	54	35	46	752,3	2569	647,4	1,98	6,75	1,70	380,8	2,15	8,58	ASHRAE MBP
	20	130	95	115										
	-10	55	32	55	598,8	2045	515,3	1,65	5,64	1,42	362,3	2,08	7,57	cecomaf MBP
	14	131	90	131										
	-10	45	20	45	669,9	2288	576,6	2,05	7,01	1,77	326,5	1,95	8,23	EN12900 MBP
	14	113	68	113										

Performance tables

R290, 220V/50Hz, CSIR, fan 3m/s, VDE, CCC

	pe		Cooling capacity			COP	EER		P1	I	m
	[°C]	[°F]	[W]	[Btu/h]	[kcal/h]		[Btu/Wh]	[kcal/Wh]			
[°C / °F]	-35	-31	248,0	847	213,4	1,20	4,10	1,03	206,5	1,56	2,78
cond. pressure	-25	-13	384,8	1314	331,2	1,51	5,16	1,30	254,8	1,70	4,34
pc= 45/113	-15	5	576,2	1968	495,9	1,90	6,48	1,63	303,6	1,86	6,56
return gas temp.	-10	14	697,4	2382	600,2	2,14	7,29	1,84	326,5	1,95	7,98
RGT= 32/90	0	32	1001,2	3419	861,7	2,73	9,34	2,35	366,2	2,10	11,61
liquid temp	5	41	1187,9	4057	1022,3	3,11	10,63	2,68	381,8	2,16	13,90
Tliq= 45/113	10	50	1400,4	4783	1205,2	3,56	12,16	3,06	393,5	2,21	16,55
[°C / °F]	-35	-31	189,1	646	162,8	0,94	3,21	0,81	201,2	1,54	2,34
cond. pressure	-25	-13	321,7	1099	276,9	1,22	4,16	1,05	264,4	1,73	4,01
pc= 55/131	-15	5	493,3	1685	424,5	1,49	5,10	1,29	330,1	1,96	6,20
return gas temp	-10	14	598,8	2045	515,3	1,65	5,64	1,42	362,3	2,08	7,57
RGT= 32/90	0	32	859,5	2935	739,7	2,04	6,95	1,75	422,2	2,32	11,04
liquid temp	5	41	1018,8	3479	876,8	2,27	7,76	1,95	448,6	2,43	13,21
Tliq= 55/131	10	50	1200,1	4099	1032,8	2,54	8,69	2,19	471,7	2,53	15,74

Model

Designation	NLE8.8CN	220-240V/50Hz	Conf. 2	Sales code:	105H6880
-------------	-----------------	----------------------	----------------	-------------	-----------------

Configuration

Motorconfiguration	RSIR
Power supply (nominal)	220-240V/50Hz 1~
Refrigerant	R290
Application	LBP+MBP
Voltage range	198-254V
Starting torque	LST
Approvals	VDE CCC

Electrical accessories / wiring diagram

RSIR

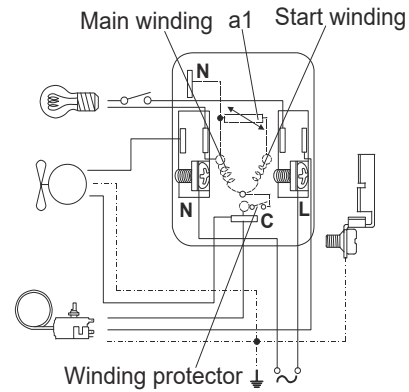
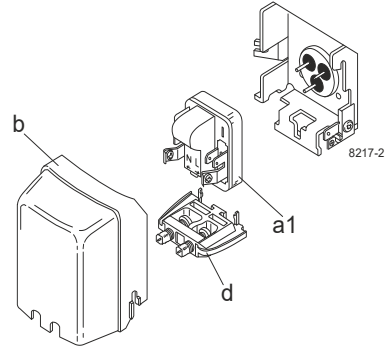

Ambient/ machine room temperatures minimum /maximum

Ambient temperature range: 10 - 43°C / 50 - 110°F

Machine room temperature range: 10 - 48°C / 50 - 119°F

Compressor cooling: fan 3m/s

Operation pressure range

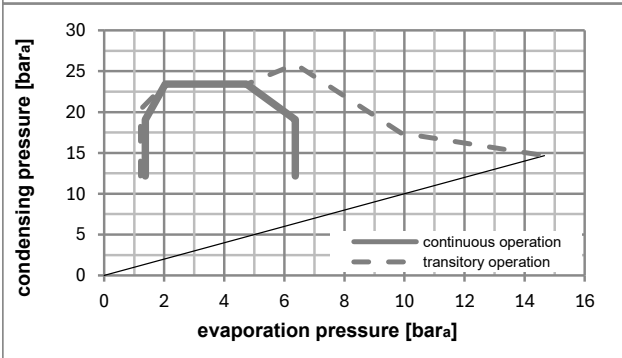
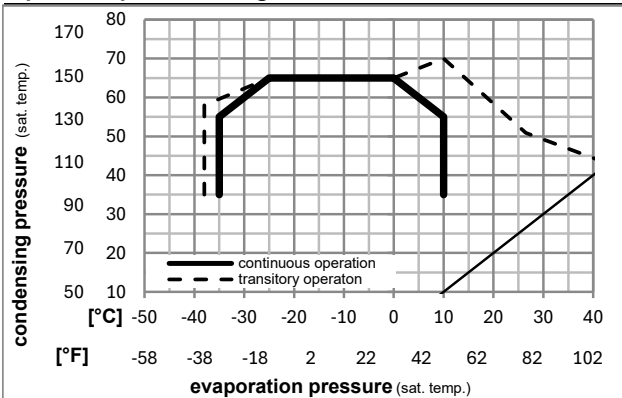

Components

a1	e-PTC starter (220V, 250hm, 4.8mm)	103N0050
b	plastic cover	103N2010
d	cord relief	103N1010

Alternative components

b	plastic cover	103N2011
---	---------------	----------

Model

Designation **NLE8.8CN** **220-240V/50Hz** Conf. 2 Sales code: **105H6880**

Optimization + standard conditions

R290, 220V/50Hz, RSIR, fan 3m/s, VDE, CCC

		Evaporating pressure (saturation temperature)				Cooling capacity			COP	EER	Power consumption				
		Condensing pressure (saturation temperature)		Return gas temp.	Liquid temp.	[W]	[Btu/h]	[kcal/h]	[W/W]	[Btu/Wh]	[kcal/Wh]	P1	I	Ref. mass flow	
[°C]	[°F]	pe	pc	RGT	Tliq							[W]	[A]	[kg/h]	
-23	-10	54	32	32		429,7	1468	369,8	1,56	5,34	1,35	274,9	1,76	4,35	ASHRAE LBP
-25	-13	55	32	55		321,7	1099	276,9	1,22	4,16	1,05	264,4	1,73	4,01	cecomaf LBP
-35	-31	40	20	40		255,5	873	219,9	1,26	4,30	1,08	203,2	1,55	2,92	EN12900 LBP
-7	20	54	35	46		752,3	2569	647,4	1,98	6,75	1,70	380,8	2,15	8,58	ASHRAE MBP
-10	14	55	32	55		598,8	2045	515,3	1,65	5,64	1,42	362,3	2,08	7,57	cecomaf MBP
-10	14	45	20	45		669,9	2288	576,6	2,05	7,01	1,77	326,5	1,95	8,23	EN12900 MBP

Performance tables

R290, 220V/50Hz, RSIR, fan 3m/s, VDE, CCC

	pe		Cooling capacity			COP	EER	P1	I	m	
	[°C]	[°F]	[W]	[Btu/h]	[kcal/h]	[W/W]	[Btu/Wh]	[kcal/Wh]	[W]	[A]	[kg/h]
[°C / °F]	-35	-31	248,0	847	213,4	1,20	4,10	1,03	206,5	1,56	2,78
cond. pressure	-25	-13	384,8	1314	331,2	1,51	5,16	1,30	254,8	1,70	4,34
pc= 45/113	-15	5	576,2	1968	495,9	1,90	6,48	1,63	303,6	1,86	6,56
return gas temp.	-10	14	697,4	2382	600,2	2,14	7,29	1,84	326,5	1,95	7,98
RGT= 32/90	0	32	1001,2	3419	861,7	2,73	9,34	2,35	366,2	2,10	11,61
liquid temp	5	41	1187,9	4057	1022,3	3,11	10,63	2,68	381,8	2,16	13,90
Tliq= 45/113	10	50	1400,4	4783	1205,2	3,56	12,16	3,06	393,5	2,21	16,55
[°C / °F]	-35	-31	189,1	646	162,8	0,94	3,21	0,81	201,2	1,54	2,34
cond. pressure	-25	-13	321,7	1099	276,9	1,22	4,16	1,05	264,4	1,73	4,01
pc= 55/131	-15	5	493,3	1685	424,5	1,49	5,10	1,29	330,1	1,96	6,20
return gas temp	-10	14	598,8	2045	515,3	1,65	5,64	1,42	362,3	2,08	7,57
RGT= 32/90	0	32	859,5	2935	739,7	2,04	6,95	1,75	422,2	2,32	11,04
liquid temp	5	41	1018,8	3479	876,8	2,27	7,76	1,95	448,6	2,43	13,21
Tliq= 55/131	10	50	1200,1	4099	1032,8	2,54	8,69	2,19	471,7	2,53	15,74

Model

Designation	NLE8.8CN	220-240V/50Hz	Conf. 3	Sales code:	105H6880
-------------	-----------------	----------------------	----------------	-------------	-----------------

Configuration

Motorconfiguration	RSCR
Power supply (nominal)	220-240V/50Hz 1~
Refrigerant	R290
Application	LBP+MBP
Voltage range	198-254V
Starting torque	LST
Approvals	VDE CCC

Electrical accessories / wiring diagram

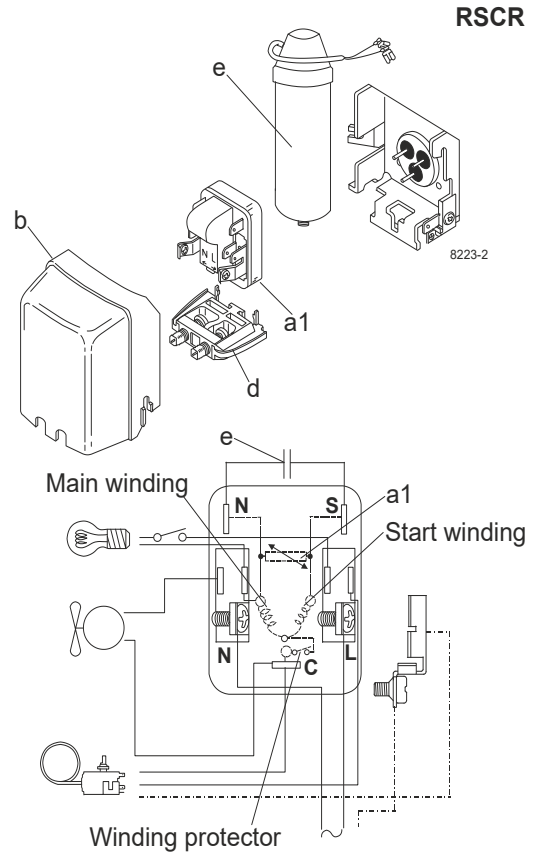

Ambient/ machine room temperatures minimum /maximum

Ambient temperature range:	10 - 43°C / 50 - 110°F
Machine room temperature range:	10 - 48°C / 50 - 119°F
Compressor cooling:	fan 3m/s

Operation pressure range

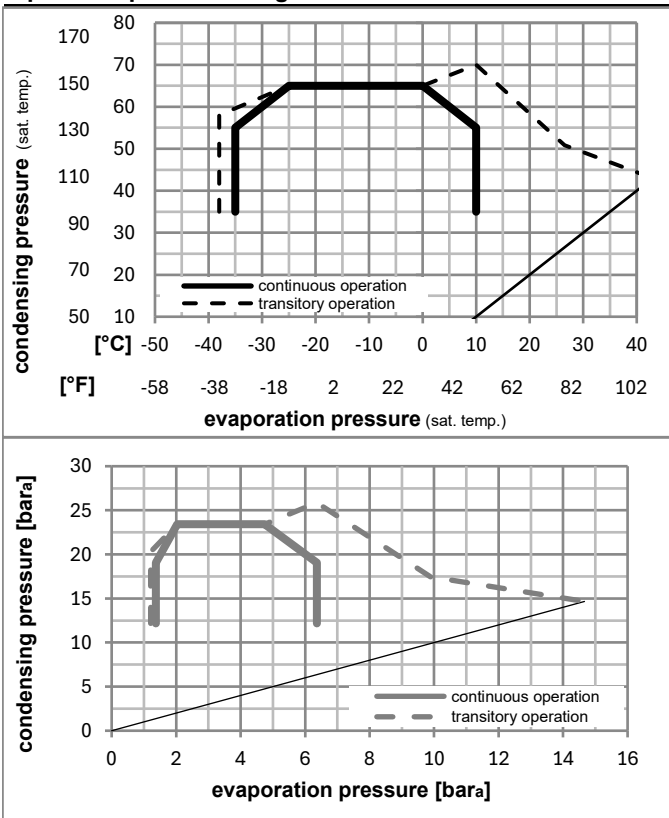

Components

a1	e-PTC starter (220V, 250hm, 4.8mm)	103N0050
e	run capacitor (4μF, 4.8mm)	117-7119
b	plastic cover	103N2010
d	cord relief	103N1010
	bracket for run capacitor	117-0300
	screw M4x8mm	117-0301

Alternative components

b	plastic cover	103N2011
---	---------------	----------

Model

Designation **NLE8.8CN** **220-240V/50Hz** Conf. 3 Sales code: **105H6880**

Optimization + standard conditions

R290, 220V/50Hz, RSCR, fan 3m/s, VDE, CCC

		Evaporating pressure (saturation temperature)			Condensing pressure (saturation temperature)			Return gas temp.			Liquid temp.			Cooling capacity			COP	EER	Power consumption			
		pe	pc	RGT	Tliq	[W]	[Btu/h]	[kcal/h]	[W/W]	[Btu/Wh]	[kcal/Wh]	P1	I	Current consumption		Ref. mass flow						
[°C]	[°F]											[W]	[A]	[A]		[kg/h]						
-23	-10	54	130	32	90	32	90	434,0	1482	373,5	1,64	5,62	1,42	263,8	1,46	4,40					ASHRAE LBP	
-25	-13	55	131	32	90	55	131	324,9	1110	279,6	1,28	4,37	1,10	253,8	1,43	4,05					cecomaf LBP	
-35	-31	40	104	20	68	40	104	258,1	881	222,1	1,32	4,49	1,13	196,2	1,30	2,95					EN12900 LBP	
-7	20	54	130	35	95	46	115	759,8	2595	653,9	2,08	7,10	1,79	365,6	1,89	8,67					ASHRAE MBP	
-10	14	55	131	32	90	55	131	604,8	2065	520,5	1,74	5,94	1,50	347,8	1,80	7,65					cecomaf MBP	
-10	14	45	113	20	68	45	113	676,6	2311	582,3	2,15	7,33	1,85	315,1	1,70	8,31					EN12900 MBP	

Performance tables

R290, 220V/50Hz, RSCR, fan 3m/s, VDE, CCC

	pe		Cooling capacity			COP	EER	P1	I	m	
	[°C]	[°F]	[W]	[Btu/h]	[kcal/h]	[W/W]	[Btu/Wh]	[kcal/Wh]	[W]	[A]	[kg/h]
[°C / °F]	-35	-31	250,5	855	215,6	1,26	4,30	1,08	198,8	1,31	2,81
cond. pressure	-25	-13	388,7	1327	334,5	1,58	5,41	1,36	245,3	1,42	4,38
pc= 45/113	-15	5	582,0	1988	500,8	1,99	6,79	1,71	292,7	1,60	6,62
return gas temp.	-10	14	704,4	2406	606,2	2,24	7,64	1,92	315,1	1,70	8,06
RGT= 32/90	0	32	1011,2	3454	870,3	2,86	9,76	2,46	353,7	1,89	11,73
liquid temp	5	41	1199,8	4097	1032,5	3,26	11,12	2,80	368,6	1,97	14,04
Tliq= 45/113	10	50	1414,4	4831	1217,3	3,73	12,72	3,21	379,7	2,02	16,71
[°C / °F]	-35	-31	191,0	652	164,4	0,99	3,37	0,85	193,5	1,26	2,36
cond. pressure	-25	-13	324,9	1110	279,6	1,28	4,37	1,10	253,8	1,43	4,05
pc= 55/131	-15	5	498,2	1701	428,8	1,57	5,37	1,35	316,9	1,67	6,26
return gas temp	-10	14	604,8	2065	520,5	1,74	5,94	1,50	347,8	1,80	7,65
RGT= 32/90	0	32	868,1	2965	747,1	2,14	7,32	1,85	404,9	2,07	11,15
liquid temp	5	41	1029,0	3514	885,6	2,39	8,18	2,06	429,7	2,18	13,34
Tliq= 55/131	10	50	1212,1	4140	1043,2	2,69	9,18	2,31	451,1	2,28	15,89



NL Compressors





Service/Repair – R600a, R290



8545

Brazing on Suction Connectors (Direct Intake)

representative image



! max. 150°C/302°F !
at socket
 brazing solder: phosphor (LP7) or silver

Refer to Product Bulletin:
Brazing on Suction Connectors
(Compressors with Direct Suction Intake)

Secop accepts no responsibility for possible errors in catalogs, brochures, and other printed material. Secop reserves the right to alter its products without notice. This also applies to products already on order provided that such alterations can be made without subsequential changes being necessary to specifications already agreed. All trademarks in this material are the property of the respective companies. Secop and the Secop logotype are trademarks of Secop GmbH. All rights reserved. www.secop.com