

Single Pack FR7GH 220-240V 50Hz / 208-230V 60Hz CSIR

Single pack code number: **195B4106**

Position	Title	Code	Amount
1	Compressor FR7GH	103G6683	1
2	Starting relay	117U6016	1
3	Starting capacitor (80 μ F 220V, 6.3mm)	117U5015	1
4	Cord relief	103N1010	1
5	Cover	103N2011	1
6	Bolt joint for one compressor M6 \varnothing 16mm	118-1917	1

Secop GmbH • Lise-Meitner-Straße 29 • 24941 Flensburg, Germany • Tel: +49 461 4941 0 • www.secop.com

Secop accepts no responsibility for possible errors in catalogs, brochures, and other printed material. Secop reserves the right to alter its products without notice. This also applies to products already on order provided that such alterations can be made without subsequent changes being necessary to specifications already agreed. All trademarks in this material are the property of the respective companies. Secop and the Secop logotype are trademarks of Secop GmbH. All rights reserved.

Model

Designation	FR7GH	220-240V/50Hz 1~ 208-230V/60Hz 1~	Sales code:	103G6683
-------------	--------------	-----------------------------------	-------------	-----------------

Compressor design

Oil type	Polyolester	Refrigerant(s)	R134a, R513A
Oil viscosity	19,2cST	Displacement	6,93cm ³ / 0,42cu.in
Oil quantity	445cm ³ / 15,1fl.oz	Compressors on pallet	80
Refr. charge - tech. limit	900g / 31,7oz		
Free gas volume comp.	1350cm ³ / 45,6fl.oz		
Weight	10,6kg / 23,4lbs		
Motor protection	1# internal		
Winding resistance main	8,8Ω (at 25°C)		
Winding resistance aux	12Ω (at 25°C)		
Max. winding temp.	125°C / 257°F		
Max. discharge temp.	130°C / 266°F		



General - Configurations with FR7GH

	Conf. 1	Conf. 2	Conf. 3	Conf. 4
Motorconfiguration	CSIR	CSIR	CSIR	CSIR
Power supply (nominal)	220-240V/50Hz	220-240V/50Hz	208-230V/60Hz	208-230V/60Hz
Number of phases	1	1	1	1
Voltage range	198-254V	198-254V	198-254V	198-254V
Approvals	CCC	CCC	CCC	CCC
Starting torque	HST	HST	HST	HST
Note	- / -			

Applications with FR7GH

	Conf. 1	Conf. 2	Conf. 3	Conf. 4
Refrigerant	R134a	R513A	R134a	R513A
Application	MBP+HBP	MBP+HBP	MBP+HBP	MBP+HBP
System cooling	fan 1,5m/s	fan 1,5m/s	fan 1,5m/s	fan 1,5m/s
Hot gas defrost	OK	OK	OK	OK
Long interval pull down	OK	OK	OK	OK

Electrical data - Configurations with FR7GH

	Conf. 1	Conf. 2	Conf. 3	Conf. 4
Starting device type	relay	relay	relay	relay
Run capacitor	- / -	- / -	- / -	- / -
Start capacitor	80μF	80μF	80μF	80μF
LRA (locked rotor amps / 4s)	9,1A	9,1A	9,1A	9,1A
RLA (rated load amps / 1s)				
Cut in current	9,1A	9,1A	9,1A	9,1A

Model

Designation

FR7GH

220-240V/50Hz 1~ 208-230V/60Hz 1~

Sales code:

103G6683

Compressor dimensions

Housing	A Height	196mm / 7,72in
	B Height	191mm / 7,52in
	C Length shell	220mm / 8,66in
	D Length w. cover	243mm / 9,57in
	E Width	156mm / 6,14in

Connectors		Suction	Discharge	Process
		X	Y	Z
Diameter	[mm]	øi 8,11-8,29	øi 8,11-8,29	øi 6,11-6,29
	(i:inside, o:outside) [in]	øi 0,32-0,33	øi 0,32-0,33	øi 0,24-0,25
Material		steel/CU	copper	steel/CU
Horizontal angle	±2°	0°	0°	0°
Vertical angle	±2°	30°	25°	150°
Position l/h/w	[mm]	125/130/55	128/102/32	-123/127/55
	[in]	4,9/5,1/2,2	5/4/1,3	-4,8/5/2,2
Straight tube l.	[mm]	12	12	12
	[in]	0,5	0,5	0,5

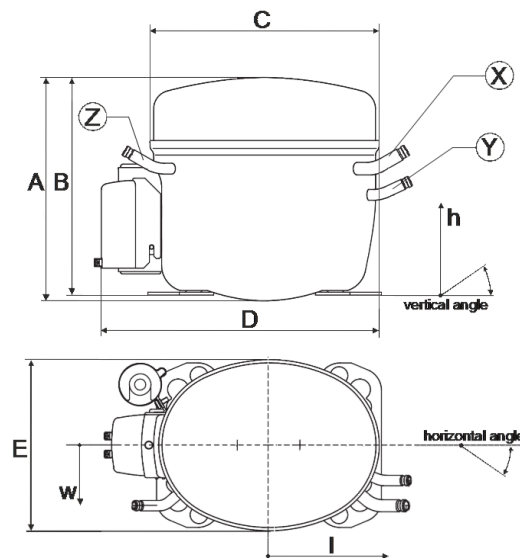

Compressor fixation

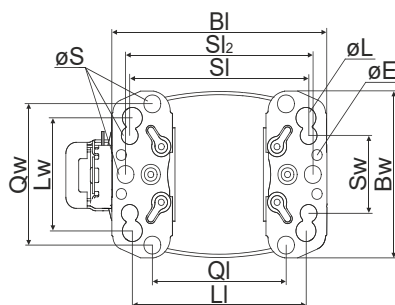

Baseplate	[mm]	[inch]
BI	204	8.03
Bw	150	5.9
øE	ø 9.7	ø 0.38
Large holes	[mm]	[inch]
LI	165	6.5
Lw	101.6	4
øL	ø 19	ø 0.75
Small holes	[mm]	[inch]
SI	170	6.7
Sw	70	2.76
øS	ø 16	ø 0.63
QI	127	5
Qw	127	5

Bolt joint

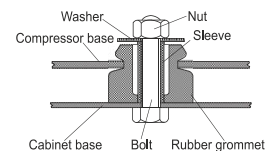

Snap-on

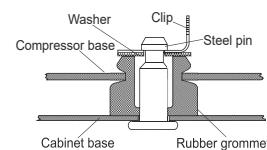

Mounting accessories

	one comp.	multi pack
Bolt joint M6 ø16mm	118-1917	118-1918
Bolt joint ø1/4" ø16mm	118-1946	
Bolt joint ø1/4" ø19mm	118-1949	
Snap-on ø7,3 ø16mm	118-1947	118-1919

Model

Designation	FR7GH	220-240V/50Hz	Conf. 1	Sales code:	103G6683
-------------	--------------	----------------------	----------------	-------------	-----------------

Configuration

Motorconfiguration	CSIR
Power supply (nominal)	220-240V/50Hz 1~
Refrigerant	R134a
Application	MBP+HBP
Voltage range	198-254V
Starting torque	HST
Approvals	CCC

Electrical accessories / wiring diagram

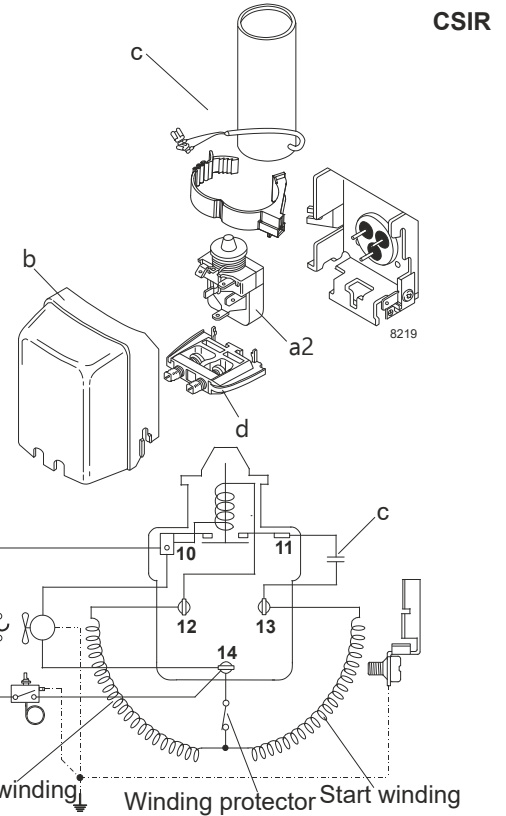

Ambient temperatures / system cooling

Ambient temperature min.:	10°C / 50°F
Ambient temperature max.:	43°C / 110°F

System cooling (n/a: outside limits)			
T ambient	LBP	MBP	HBP
32°C / 90°F	n/a	fan 1,5m/s	fan 1,5m/s
38°C / 100°F	n/a	fan 1,5m/s	fan 1,5m/s
43°C / 110°F	n/a	fan 1,5m/s	fan 1,5m/s

Operation pressure range

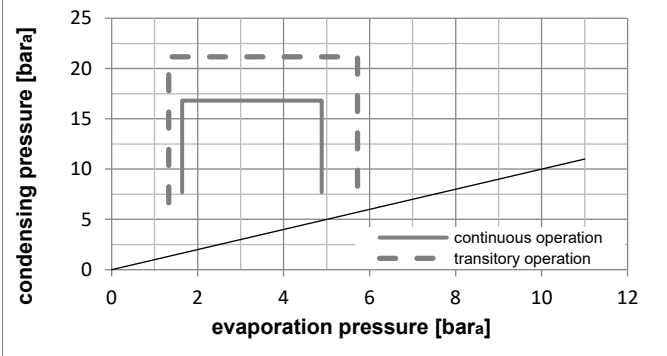
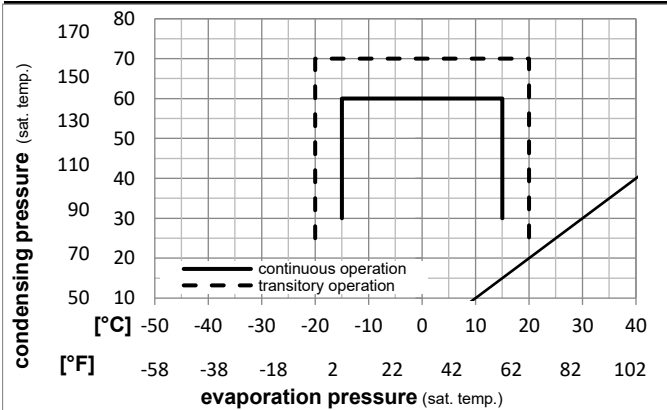

Components

a2	relay	117U6016
c	start capacitor (80μF)	117U5015
b	plastic cover	103N2011
d	cord relief	103N1010

Model

Designation **FR7GH** **220-240V/50Hz** Conf. 1 Sales code: **103G6683**

Optimization + standard conditions

R134a, 220V/50Hz, CSIR, fan 1,5m/s, CCC

		Evaporating pressure (saturation temperature)				Condensing pressure (saturation temperature)						Power consumption			
		Return gas temp.				Liquid temp.						Current consumption			Ref. mass flow
		Cooling capacity				COP		EER		P1	I	m			
		pe	pc	RGT	Tliq	[W]	[Btu/h]	[kcal/h]	[W/W]	[Btu/Wh]	[kcal/Wh]	[W]	[A]	[kg/h]	
[°C]	7,2	54	35	46	645,2	2203	555,2	2,44	8,33	2,10	264,6	1,72	14,31	ASHRAE HBP	
[°F]	45	130	95	115											
[°C]	5	55	32	55	525,4	1794	452,1	2,04	6,95	1,75	258,2	1,70	12,95	cecomaf HBP	
[°F]	41	131	90	131											
[°C]	5	50	20	50	553,7	1891	476,5	2,23	7,60	1,92	248,7	1,67	13,95	EN12900 HBP	
[°F]	41	122	68	122											
[°C]	-7	54	35	46	334,8	1143	288,1	1,60	5,47	1,38	208,9	1,53	7,30	ASHRAE MBP	
[°F]	20	130	95	115											
[°C]	-10	55	32	55	255,2	872	219,7	1,33	4,53	1,14	192,4	1,47	6,17	cecomaf MBP	
[°F]	14	131	90	131											
[°C]	-10	45	20	45	301,9	1031	259,8	1,61	5,51	1,39	187,2	1,48	7,07	EN12900 MBP	
[°F]	14	113	68	113											

Performance tables

R134a, 220V/50Hz, CSIR, fan 1,5m/s, CCC

	pe		Cooling capacity			COP	EER	P1	I	m	
	[°C]	[°F]	[W]	[Btu/h]	[kcal/h]	[W/W]	[Btu/Wh]	[kcal/Wh]	[W]	[A]	[kg/h]
[°C / °F]	-15	5	242,0	826	208,2	1,47	5,02	1,27	164,5	1,42	5,27
cond. pressure	-10	14	313,2	1070	269,5	1,67	5,71	1,44	187,2	1,48	6,85
pc= 45/113	-5	23	400,9	1369	345,0	1,94	6,62	1,67	206,9	1,54	8,82
return gas temp.	0	32	506,7	1730	436,1	2,26	7,73	1,95	223,8	1,60	11,21
RGT= 32/90	5	41	632,3	2160	544,2	2,66	9,08	2,29	237,8	1,64	14,08
liquid temp	10	50	779,5	2662	670,8	3,13	10,69	2,69	249,0	1,68	17,49
Tliq= 45/113	15	59	949,8	3244	817,4	3,69	12,61	3,18	257,2	1,72	21,51
[°C / °F]	-15	5	199,0	680	171,2	1,21	4,13	1,04	164,7	1,38	4,79
cond. pressure	-10	14	255,2	872	219,7	1,33	4,53	1,14	192,4	1,47	6,17
pc= 55/131	-5	23	327,3	1118	281,7	1,51	5,15	1,30	217,2	1,55	7,96
return gas temp	0	32	416,8	1423	358,7	1,74	5,95	1,50	239,1	1,63	10,19
RGT= 32/90	5	41	525,4	1794	452,1	2,04	6,95	1,75	258,2	1,70	12,95
liquid temp	10	50	654,8	2236	563,5	2,39	8,15	2,05	274,3	1,76	16,28
Tliq= 55/131	15	59	806,7	2755	694,2	2,80	9,58	2,41	287,6	1,81	20,26

Model

Designation	FR7GH	220-240V/50Hz	Conf. 2	Sales code:	103G6683
-------------	--------------	----------------------	----------------	-------------	-----------------

Configuration

Motorconfiguration	CSIR
Power supply (nominal)	220-240V/50Hz 1~
Refrigerant	R513A
Application	MBP+HBP
Voltage range	198-254V
Starting torque	HST
Approvals	CCC

Electrical accessories / wiring diagram

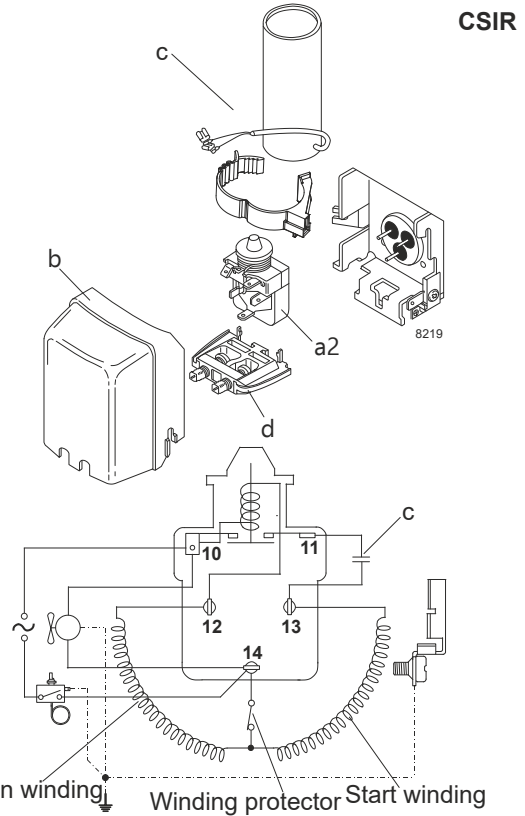

Ambient temperatures / system cooling

Ambient temperature min.:	10°C / 50°F
Ambient temperature max.:	43°C / 110°F

System cooling (n/a: outside limits)			
T ambient	LBP	MBP	HBP
32°C / 90°F	n/a	fan 1,5m/s	fan 1,5m/s
38°C / 100°F	n/a	fan 1,5m/s	fan 1,5m/s
43°C / 110°F	n/a	fan 1,5m/s	fan 1,5m/s

Operation pressure range

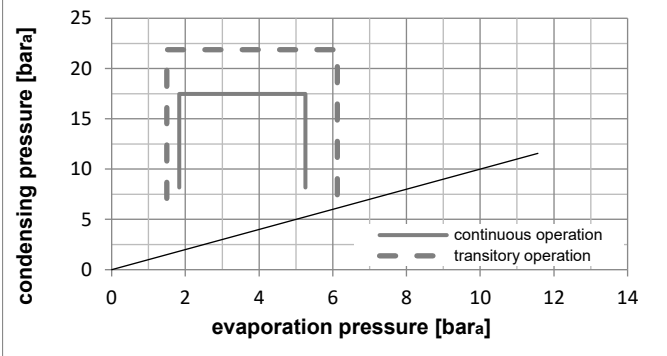
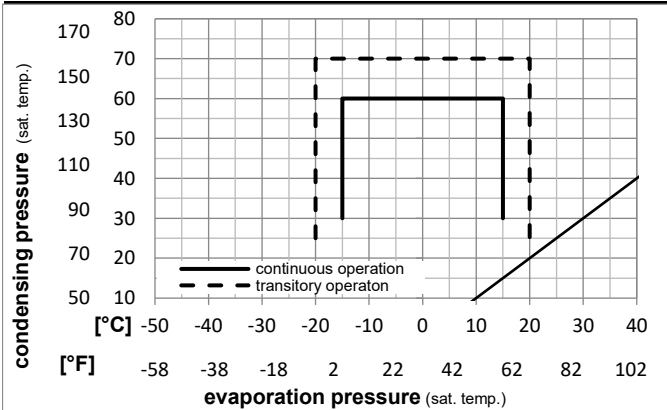

Components

a2	relay	117U6016
c	start capacitor (80μF)	117U5015
b	plastic cover	103N2011
d	cord relief	103N1010

Model

Designation **FR7GH** **220-240V/50Hz** Conf. 2 Sales code: **103G6683**

Optimization + standard conditions

R513A, 220V/50Hz, CSIR, fan 1,5m/s, CCC

		Evaporating pressure (saturation temperature)				Condensing pressure (saturation temperature)			Return gas temp.			Liquid temp.			Cooling capacity			COP	EER	Power consumption			
		pe	pc	RGT	Tliq	[W]	[Btu/h]	[kcal/h]	[W/W]	[Btu/Wh]	[kcal/Wh]	P1	I	m	[W]	[A]	[kg/h]						
[°C]	[°F]																						
7,2	45	54	35	46	664,6	2270	572,0	2,41	8,24	2,08	275,5	1,77	16,51								ASHRAE HBP		
5	41	55	32	55	533,3	1821	459,0	1,98	6,76	1,70	269,4	1,75	14,99								cecomaf HBP		
5	41	50	20	50	563,0	1923	484,5	2,17	7,41	1,87	259,5	1,72	16,14								EN12900 HBP		
-7	20	54	35	46	353,1	1206	303,9	1,60	5,46	1,38	220,9	1,59	8,65								ASHRAE MBP		
-10	14	55	32	55	266,4	910	229,3	1,30	4,46	1,12	204,2	1,54	7,37								cecomaf MBP		
-10	14	45	20	45	316,9	1082	272,7	1,60	5,47	1,38	198,0	1,52	8,40								EN12900 MBP		

Performance tables

R513A, 220V/50Hz, CSIR, fan 1,5m/s, CCC

	pe		Cooling capacity			COP	EER	P1			I	m
	[°C]	[°F]	[W]	[Btu/h]	[kcal/h]	[W/W]	[Btu/Wh]	[kcal/Wh]	[W]	[A]	[kg/h]	
[°C / °F]	-15	5	258,8	884	222,8	1,48	5,06	1,27	174,9	1,45	6,34	
cond. pressure	-10	14	331,4	1132	285,2	1,67	5,72	1,44	198,0	1,52	8,15	
pc= 45/113	-5	23	420,1	1435	361,6	1,93	6,59	1,66	217,8	1,58	10,37	
return gas temp.	0	32	526,7	1799	453,3	2,25	7,67	1,93	234,5	1,64	13,06	
RGT= 32/90	5	41	652,7	2229	561,7	2,63	8,99	2,26	248,0	1,68	16,28	
liquid temp	10	50	799,5	2730	688,0	3,09	10,56	2,66	258,5	1,71	20,07	
Tliq= 45/113	15	59	968,7	3308	833,7	3,64	12,43	3,13	266,1	1,74	24,51	
[°C / °F]	-15	5	210,3	718	181,0	1,20	4,08	1,03	176,0	1,45	5,79	
cond. pressure	-10	14	266,4	910	229,3	1,30	4,46	1,12	204,2	1,54	7,37	
pc= 55/131	-5	23	337,9	1154	290,8	1,47	5,04	1,27	229,2	1,62	9,39	
return gas temp	0	32	426,4	1456	367,0	1,70	5,80	1,46	250,9	1,69	11,91	
RGT= 32/90	5	41	533,3	1821	459,0	1,98	6,76	1,70	269,4	1,75	14,99	
liquid temp	10	50	660,3	2255	568,3	2,32	7,91	1,99	284,9	1,80	18,69	
Tliq= 55/131	15	59	808,9	2762	696,1	2,72	9,29	2,34	297,4	1,84	23,10	

Model

Designation	FR7GH	208-230V/60Hz	Conf. 3	Sales code:	103G6683
-------------	--------------	----------------------	----------------	-------------	-----------------

Configuration

Motorconfiguration	CSIR
Power supply (nominal)	208-230V/60Hz 1~
Refrigerant	R134a
Application	MBP+HBP
Voltage range	198-254V
Starting torque	HST
Approvals	CCC

Electrical accessories / wiring diagram

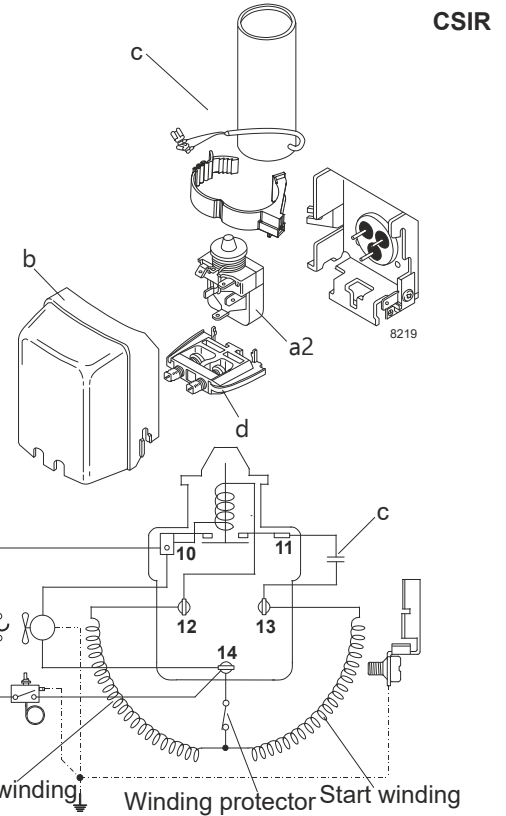

Ambient temperatures / system cooling

Ambient temperature min.:	10°C / 50°F
Ambient temperature max.:	43°C / 110°F

System cooling (n/a: outside limits)			
T ambient	LBP	MBP	HBP
32°C / 90°F	n/a	fan 1,5m/s	fan 1,5m/s
38°C / 100°F	n/a	fan 1,5m/s	fan 1,5m/s
43°C / 110°F	n/a	fan 1,5m/s	fan 1,5m/s

Operation pressure range

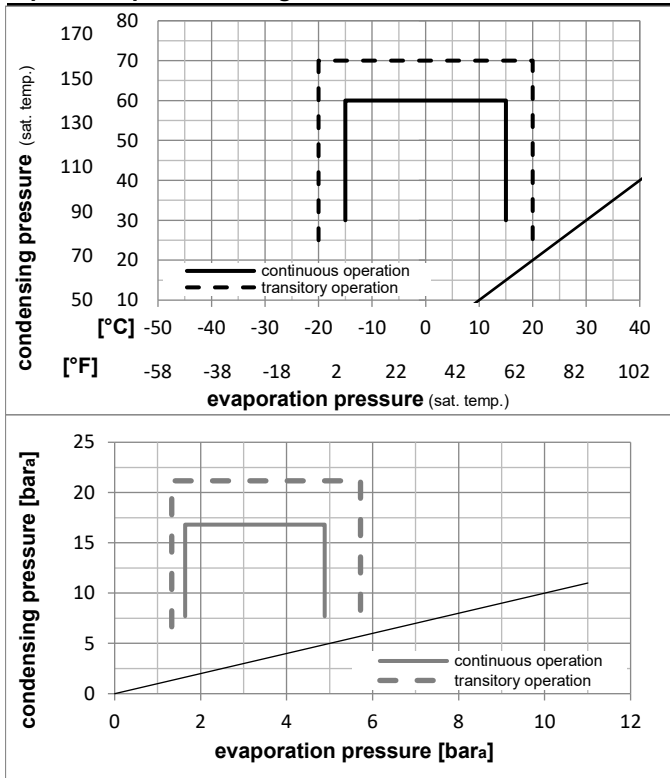

Components

a2	relay	117U6016
c	start capacitor (80μF)	117U5015
b	plastic cover	103N2011
d	cord relief	103N1010

Model

Designation **FR7GH** **208-230V/60Hz** Conf. 3 Sales code: **103G6683**

Optimization + standard conditions

R134a, 230V/60Hz, CSIR, fan 1,5m/s, CCC

		Evaporating pressure (saturation temperature)				Condensing pressure (saturation temperature)			Return gas temp.			Liquid temp.			Cooling capacity			COP	EER	Power consumption			
		pe	pc	RGT	Tliq	[W]	[Btu/h]	[kcal/h]	[W/W]	[Btu/Wh]	[kcal/Wh]	P1	I	m	[W]	[A]	[kg/h]						
[°C]	[°F]																						
		7,2	54	35	46	742,7	2537	639,2	2,26	7,71	1,94	329,1	1,85	16,48							ASHRAE HBP		
		45	130	95	115																		
		5	55	32	55	606,5	2071	522,0	1,91	6,54	1,65	316,9	1,79	14,95							cecomaf HBP		
		41	131	90	131																		
		5	50	20	50	632,6	2160	544,4	2,12	7,23	1,82	299,0	1,74	15,94							EN12900 HBP		
		41	122	68	122																		
		-7	54	35	46	386,6	1320	332,7	1,62	5,53	1,39	238,6	1,49	8,43							ASHRAE MBP		
		20	130	95	115																		
		-10	55	32	55	293,9	1004	252,9	1,35	4,62	1,16	217,4	1,41	7,11							cecomaf MBP		
		14	131	90	131																		
		-10	45	20	45	341,4	1166	293,8	1,62	5,52	1,39	211,2	1,41	7,99							EN12900 MBP		
		14	113	68	113																		

Performance tables

R134a, 230V/60Hz, CSIR, fan 1,5m/s, CCC

	pe		Cooling capacity			COP	EER	P1			I	m
	[°C]	[°F]	[W]	[Btu/h]	[kcal/h]	[W/W]	[Btu/Wh]	[kcal/Wh]	[W]	[A]	[kg/h]	
[°C / °F]	-15	5	271,1	926	233,3	1,46	4,99	1,26	185,7	1,34	5,91	
cond. pressure	-10	14	354,2	1210	304,8	1,68	5,73	1,44	211,2	1,41	7,75	
pc= 45/113	-5	23	454,9	1554	391,5	1,93	6,58	1,66	236,2	1,49	10,00	
return gas temp.	0	32	575,4	1965	495,2	2,21	7,54	1,90	260,6	1,58	12,72	
RGT= 32/90	5	41	717,6	2451	617,5	2,52	8,62	2,17	284,4	1,68	15,98	
liquid temp	10	50	883,5	3017	760,3	2,87	9,81	2,47	307,6	1,80	19,82	
Tliq= 45/113	15	59	1075,2	3672	925,3	3,26	11,12	2,80	330,1	1,92	24,35	
[°C / °F]	-15	5	225,3	770	193,9	1,22	4,18	1,05	184,1	1,31	5,42	
cond. pressure	-10	14	293,9	1004	252,9	1,35	4,62	1,16	217,4	1,41	7,11	
pc= 55/131	-5	23	378,9	1294	326,1	1,51	5,16	1,30	250,6	1,53	9,21	
return gas temp	0	32	482,4	1648	415,2	1,70	5,81	1,46	283,8	1,65	11,80	
RGT= 32/90	5	41	606,5	2071	522,0	1,91	6,54	1,65	316,9	1,79	14,95	
liquid temp	10	50	753,2	2572	648,2	2,15	7,35	1,85	349,9	1,94	18,72	
Tliq= 55/131	15	59	924,5	3157	795,6	2,42	8,25	2,08	382,7	2,10	23,22	

Model

Designation	FR7GH	208-230V/60Hz	Conf. 4	Sales code:	103G6683
-------------	--------------	----------------------	----------------	-------------	-----------------

Configuration

Motorconfiguration	CSIR
Power supply (nominal)	208-230V/60Hz 1~
Refrigerant	R513A
Application	MBP+HBP
Voltage range	198-254V
Starting torque	HST
Approvals	CCC

Electrical accessories / wiring diagram

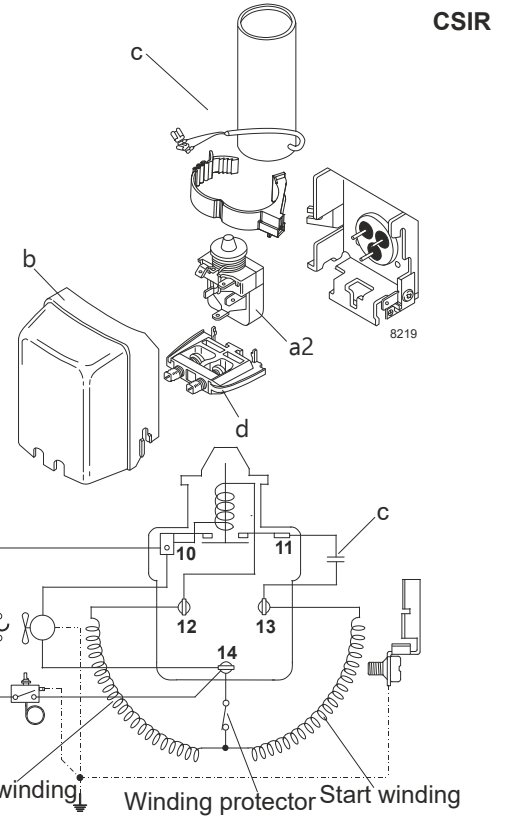

Ambient temperatures / system cooling

Ambient temperature min.:	10°C / 50°F
Ambient temperature max.:	43°C / 110°F

System cooling (n/a: outside limits)			
T ambient	LBP	MBP	HBP
32°C / 90°F	n/a	fan 1,5m/s	fan 1,5m/s
38°C / 100°F	n/a	fan 1,5m/s	fan 1,5m/s
43°C / 110°F	n/a	fan 1,5m/s	fan 1,5m/s

Operation pressure range

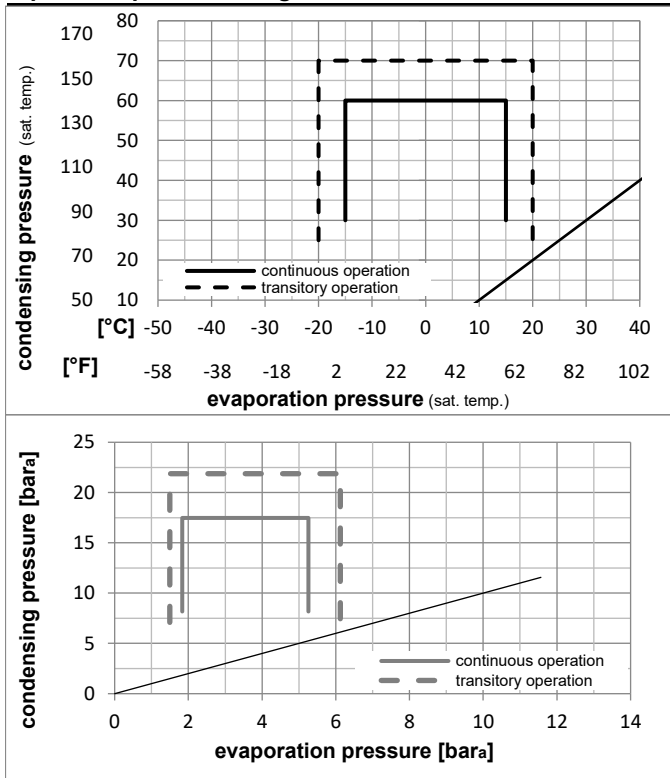

Components

a2	relay	117U6016
c	start capacitor (80μF)	117U5015
b	plastic cover	103N2011
d	cord relief	103N1010

Model

Designation **FR7GH** **208-230V/60Hz** Conf. 4 Sales code: **103G6683**

Optimization + standard conditions

R513A, 230V/60Hz, CSIR, fan 1,5m/s, CCC

Evaporating pressure (saturation temperature)					Condensing pressure (saturation temperature)						Power consumption			
					Return gas temp.			Liquid temp.			Current consumption		Ref. mass flow	
					Cooling capacity			COP	EER	P1		I	m	
					[W]	[Btu/h]	[kcal/h]	[W/W]	[Btu/Wh]	[kcal/Wh]	[W]	[A]	[kg/h]	
[°C]	7,2	54	35	46	765,0	2613	658,4	2,22	7,60	1,91	343,8	1,96	19,01	ASHRAE HBP
[°F]	45	130	95	115										
[°C]	5	55	32	55	615,7	2103	529,9	1,86	6,34	1,60	331,8	1,92	17,30	cecomaf HBP
[°F]	41	131	90	131										
[°C]	5	50	20	50	643,2	2197	553,6	2,06	7,02	1,77	312,9	1,84	18,44	EN12900 HBP
[°F]	41	122	68	122										
[°C]	-7	54	35	46	407,7	1392	350,9	1,61	5,50	1,39	253,1	1,60	9,99	ASHRAE MBP
[°F]	20	130	95	115										
[°C]	-10	55	32	55	306,7	1048	264,0	1,32	4,52	1,14	231,7	1,51	8,48	cecomaf MBP
[°F]	14	131	90	131										
[°C]	-10	45	20	45	358,3	1224	308,4	1,60	5,46	1,37	224,3	1,49	9,50	EN12900 MBP
[°F]	14	113	68	113										

Performance tables

R513A, 230V/60Hz, CSIR, fan 1,5m/s, CCC

	pe		Cooling capacity			COP	EER	P1			I	m
	[°C]	[°F]	[W]	[Btu/h]	[kcal/h]	[W/W]	[Btu/Wh]	[kcal/Wh]	[W]	[A]	[kg/h]	
[°C / °F]	-15	5	289,9	990	249,5	1,46	4,99	1,26	198,4	1,38	7,10	
cond. pressure	-10	14	374,7	1280	322,5	1,67	5,71	1,44	224,3	1,49	9,21	
pc= 45/113	-5	23	476,8	1628	410,3	1,91	6,53	1,65	249,4	1,59	11,77	
return gas temp.	0	32	598,2	2043	514,8	2,18	7,46	1,88	273,8	1,68	14,84	
RGT= 32/90	5	41	740,6	2529	637,4	2,49	8,50	2,14	297,5	1,78	18,47	
liquid temp	10	50	906,1	3094	779,8	2,83	9,66	2,43	320,4	1,87	22,75	
Tliq= 45/113	15	59	1096,4	3744	943,6	3,20	10,93	2,75	342,5	1,96	27,74	
[°C / °F]	-15	5	238,2	813	205,0	1,20	4,11	1,04	197,8	1,38	6,56	
cond. pressure	-10	14	306,7	1048	264,0	1,32	4,52	1,14	231,7	1,51	8,48	
pc= 55/131	-5	23	391,2	1336	336,7	1,47	5,04	1,27	265,3	1,65	10,87	
return gas temp	0	32	493,6	1686	424,8	1,65	5,64	1,42	298,7	1,78	13,79	
RGT= 32/90	5	41	615,7	2103	529,9	1,86	6,34	1,60	331,8	1,92	17,30	
liquid temp	10	50	759,5	2594	653,6	2,08	7,11	1,79	364,7	2,05	21,50	
Tliq= 55/131	15	59	926,7	3165	797,6	2,33	7,97	2,01	397,2	2,18	26,47	