

## Single Pack FF8.5GX 115V 60Hz CSIR

Single pack code number: **195B4109**

Position	Title	Code	Amount
1	Compressor FF8.5GX	103G5880	1
2	Starting relay (overload protector MRP36AEN-6)	117U4060	1
3	Starting capacitor (280 $\mu$ F 125V, 6.3mm)	117U5041	1
4	Cord relief	117U0349	2
5	Cover	117U1021	1
6	Bolt joint for one compressor   M6   $\varnothing$ 16mm	118-1917	1

Secop GmbH • Lise-Meitner-Straße 29 • 24941 Flensburg, Germany • Tel: +49 461 4941 0 • [www.secop.com](http://www.secop.com)

Secop accepts no responsibility for possible errors in catalogs, brochures, and other printed material. Secop reserves the right to alter its products without notice. This also applies to products already on order provided that such alterations can be made without subsequent changes being necessary to specifications already agreed. All trademarks in this material are the property of the respective companies. Secop and the Secop logotype are trademarks of Secop GmbH. All rights reserved.

## FF8.5GX Universal Compressor R134a 115V 60Hz

### General

Code number	103G5880
Approvals	UL984
Compressors on pallet	80

### Application

Application	LBP/HBP			
Frequency	Hz	50	60	
Evaporating temperature	°F	-	-22 to 50	
Voltage range	V	-	103 - 127	
Max. condensing temperature continuous (short)	°F	-	140 (158)	
Max. winding temperature continuous (short)	°F	-	257 (275)	

### Cooling requirements

Frequency	Hz	50			60		
Application		LBP	MBP	HBP	LBP	MBP	HBP
90°F		-	-	-	F <sub>1</sub>	F <sub>1</sub>	F <sub>1</sub>
100°F		-	-	-	F <sub>1</sub>	F <sub>1</sub>	F <sub>1</sub>
110°F		-	-	-	F <sub>1</sub>	F <sub>1</sub>	F <sub>1</sub>
Remarks on application:							

### Motor

Motor type	CSIR		
LRA (rated after 4 sec. UL984), HST   LST	A	28.0	-
Cut in Current, HST   LST	A	28.0	-
Resistance, main   start winding (77°F)	Ω	1.9	6.6

### Design

Displacement	cu.in	0.48
Oil quantity (type)	fl.oz.	13.5 (polyolester)
Maximum refrigerant charge	oz.	32.0
Free gas volume in compressor	fl.oz.	47.3
Weight without electrical equipment	lbs.	23.3

### Dimensions

Height	inch	A	7.72
		B	7.52
		B1	-
		B2	-
Suction connector	location, I.D. in.   angle	C	0.320-0.327   30°
	material   comment		Cu-plated steel   Al cap
Process connector	location, I.D. in.   angle	D	0.252-0.259   30°
	material   comment		Cu-plated steel   Al cap
Discharge connector	location, I.D. in.   angle	E	0.252-0.259   25°
	material   comment		Cu-plated steel   Al cap
Oil cooler connector	location, I.D. in.   angle	F	-
	material   comment		-
Remarks:			

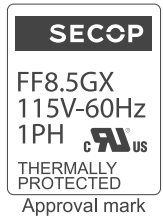
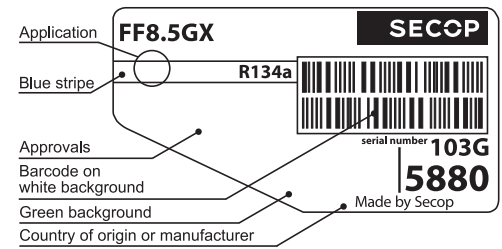

- S = Static cooling normally sufficient
- O = Oil cooling
- F<sub>1</sub> = Fan cooling 1.5 m/s  
(compressor compartment temperature equal to ambient temperature)
- F<sub>2</sub> = Fan cooling 3.0 m/s necessary
- SG = Suction gas cooling normally sufficient
- = not applicable in this area

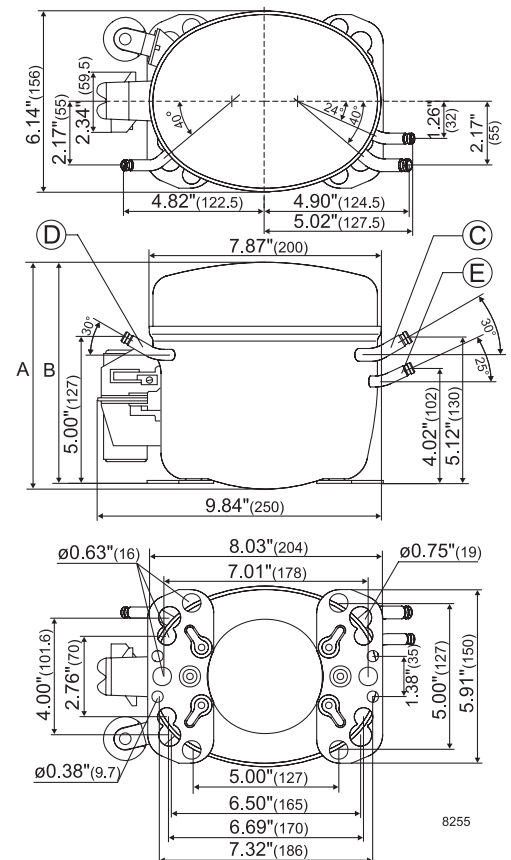

**ASHRAE LBP**

115V, 60Hz, fan cooling F<sub>1</sub>

Evap. temp. in °F	-49	-40	-30	-20	-13	-10	0	10	14	20	30	32	40	45	50	59	68
Capacity in BTU/h				443	588	662	957	1328	1490	1773	2294	2404	2890	3217	3563		
Power cons. in W				172	198	209	245	283	299	321	359	369	398	418	437		
Current cons. in A				3.13	3.22	3.27	3.45	3.67	3.77	3.92	4.19	4.25	4.46	4.59	4.72		
EER in BTU/Wh				2.57	2.98	3.18	3.90	4.69	4.98	5.53	6.38	6.51	7.26	7.70	8.14		

**ASHRAE HBP**

115V, 60Hz, fan cooling F<sub>1</sub>

Evap. temp. in °F	-49	-40	-30	-20	-13	-10	0	10	14	20	30	32	40	45	50	59	68
Capacity in BTU/h				392	522	587	848	1176	1336	1570	2029	2141	2555	2842	3146		
Power cons. in W				172	198	209	245	283	297	321	359	366	398	418	437		
Current cons. in A				3.13	3.22	3.27	3.45	3.67	3.77	3.92	4.19	4.24	4.46	4.59	4.72		
EER in BTU/Wh				2.28	2.64	2.81	3.46	4.16	4.50	4.89	5.65	5.83	6.41	6.80	7.19		

**EN 12900 Household (CECOMAF)**

115V, 60Hz, fan cooling F<sub>1</sub>

Evap. temp. in °F	-49	-40	-30	-20	-13	-10	0	10	14	20	30	32	40	45	50	59	68
Capacity in W				106	141	158	229	317	354	423	547	569	688	765	846		
Power cons. in W				172	198	209	245	283	299	321	359	369	398	418	437		
Current cons. in A				3.13	3.22	3.27	3.45	3.67	3.77	3.92	4.19	4.25	4.46	4.59	4.72		
COP in W/W				0.61	0.71	0.76	0.93	1.12	1.18	1.32	1.52	1.54	1.73	1.83	1.93		

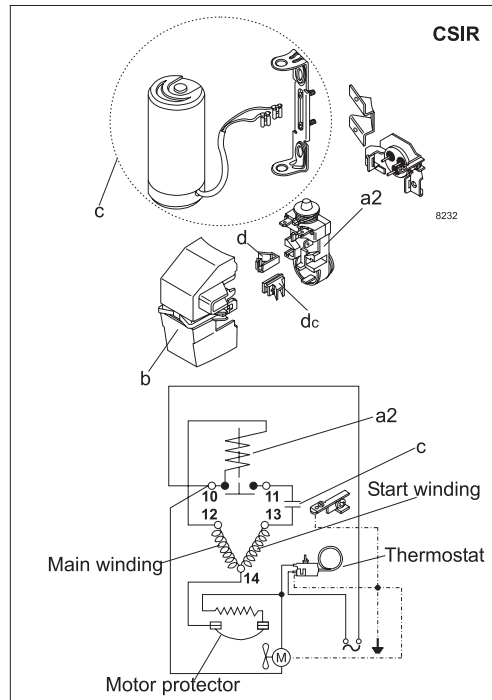

Accessories for	FF8.5GX	Figure	Code number	Test conditions	ASHRAE LBP	ASHRAE HBP	EN 12900/CECOMAF
Starting relay	1/4 in. spade connect.	a2	117U4060	Condensing temp.	130°F	130°F	131°F
Protector 3/4 in.	Texas Instruments		MRP36AEN-6	Ambient temp.	90°F	95°F	90°F
Cover		b	117U1021	Suction gas temp.	90°F	95°F	90°F
Start. capacitor 280 µF	1/4 in. spade connect.	c	117U5041	Liquid temperature	90°F	115°F	131°F
Cord relief		d	117U0349				
Cord relief for capacitor		dc	117U0349				
<b>Mounting accessories</b>					<b>Code number</b>		
Bolt joint for one comp.					Ø: 5/8 in.	118-1917	
Bolt joint in quantities					Ø: 5/8 in.	118-1918	
Snap-on in quantities					Ø: 5/8 in.	118-1919	

Secop accepts no responsibility for possible errors in catalogs, brochures, and other printed material. Secop reserves the right to alter its products without notice. This also applies to products already on order provided that such alterations can be made without subsequential changes being necessary to specifications already agreed. All trademarks in this material are the property of the respective companies. Secop and the Secop logotype are trademarks of Secop GmbH. All rights reserved. [www.secop.com](http://www.secop.com)

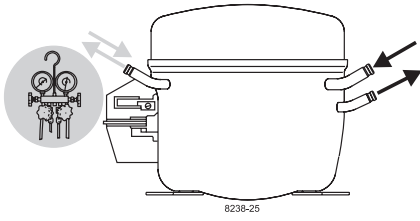

# FF Compressors

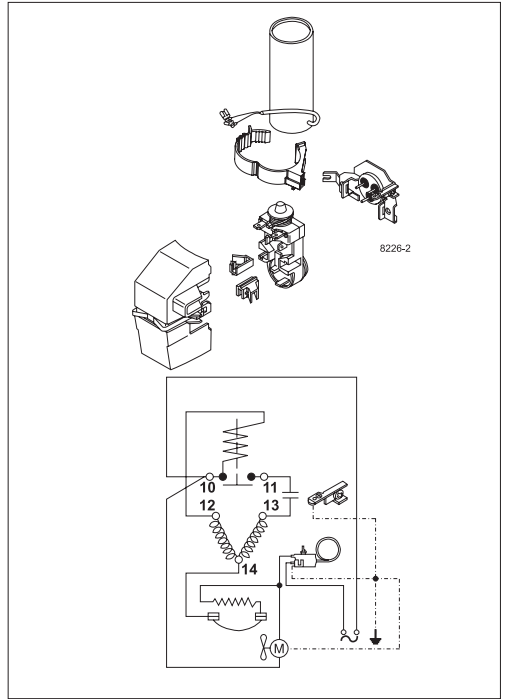
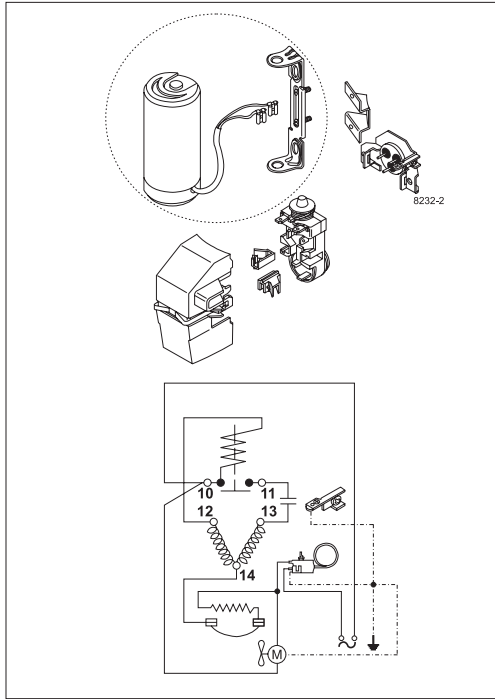
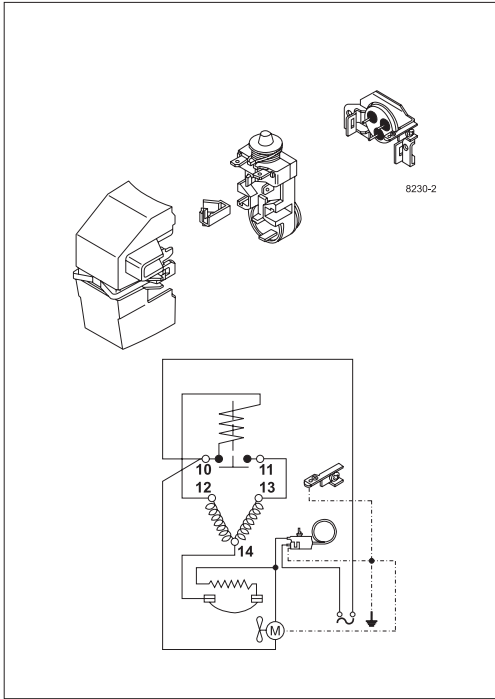

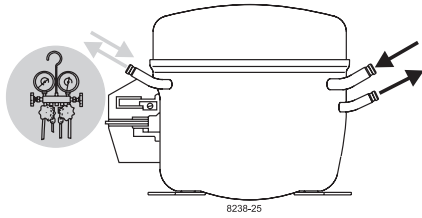

# FF Compressors



8238-25

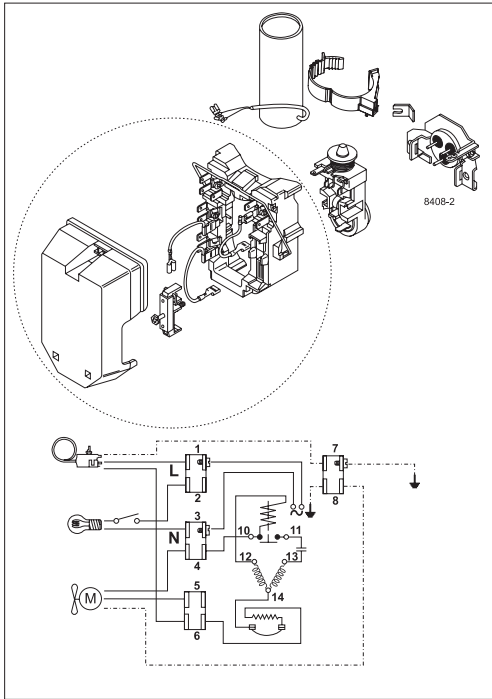
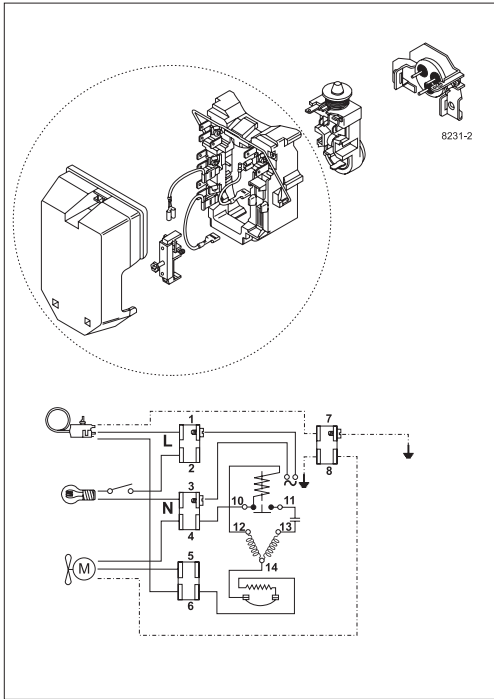

Secop accepts no responsibility for possible errors in catalogs, brochures, and other printed material. Secop reserves the right to alter its products without notice. This also applies to products already on order provided that such alterations can be made without subsequential changes being necessary to specifications already agreed. All trademarks in this material are the property of the respective companies. Secop and the Secop logotype are trademarks of Secop GmbH. All rights reserved. [www.secop.com](http://www.secop.com)