

Single Pack BD350GH 24V DC PM

Single pack code number: **195B4186**

Position	Title	Code	Amount
1	Compressor BD350GH	102Z3016	1
2	Electronic unit	101N0715	1
3	Bolt joint for one compressor M6 ø16mm	118-1917	1

Secop GmbH • Lise-Meitner-Straße 29 • 24941 Flensburg, Germany • Tel: +49 461 4941 0 • www.secop.com

Secop accepts no responsibility for possible errors in catalogs, brochures, and other printed material. Secop reserves the right to alter its products without notice. This also applies to products already on order provided that such alterations can be made without subsequent changes being necessary to specifications already agreed. All trademarks in this material are the property of the respective companies. Secop and the Secop logotype are trademarks of Secop GmbH. All rights reserved.

BD350GH Direct Current Compressor R134a 24V DC - with 101N07xx Series Controllers

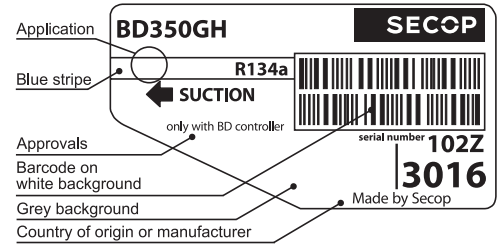

General

Code number (without electronic units)	102Z3016
Electronic unit	101N0715, 36 pcs: 101N0714
Approvals	-
Compressors on pallet	125

Application

Application	LBP/MBP/HBP	
Evaporating temperature °C	-25 to 15	
Voltage range VDC	19 - 31.5	
Max. condensing temperature continuous (short) °C	60 (70)	
Max. winding temperature continuous (short) °C	125 (135)	

- S = Static cooling normally sufficient
- O = Oil cooling
- F₁ = Fan cooling 1.5 m/s
(compressor compartment temperature equal to ambient temperature)
- F₂ = Fan cooling 3.0 m/s necessary
- SG = Suction gas cooling normally sufficient
- = not applicable in this area

Cooling requirements

Application	LBP	MBP	HBP
32°C	F ₁	F ₁	F ₁
38°C	F ₁	F ₁	F ₁
43°C	F ₁	F ₁	F ₁

Remarks on application:
 - evaporator fan max. 60W
 - condenser fan max. 40W
 - starting ability: LST (low starting torque) only

Motor

Motor type	variable speed
Resistance, all 3 windings (25°C) Ω	0.2

Design

Displacement cm ³	5.08
Oil quantity (type) cm ³	280 (polyolester)
Maximum refrigerant charge g	400
Free gas volume in compressor cm ³	1690
Weight - Compressor/Electronic unit kg	7.9/0.27

Battery protection settings

Voltage	Min. value	Default	Max. value
Cut out (0.1 steps) VDC	19.0	21.1	27.0
Cut in diff. (0.1 steps) VDC	0.5	3.9	10.0

Dimensions

Height mm	A	173
	B	169
	B1	-
	B2	-
Suction connector location/I.D. mm angle	C	6.2 90°
	material comment	Cu-plated steel Al cap
Process connector location/I.D. mm angle	D	6.2 31.5°
	material comment	Cu-plated steel Al cap
Discharge connector location/I.D. mm angle	E	5.0 28°
	material comment	Cu-plated steel Al cap
Connector tolerance I.D. mm	±0.09, on 5.0 +0.12/+0.20	
Remarks		

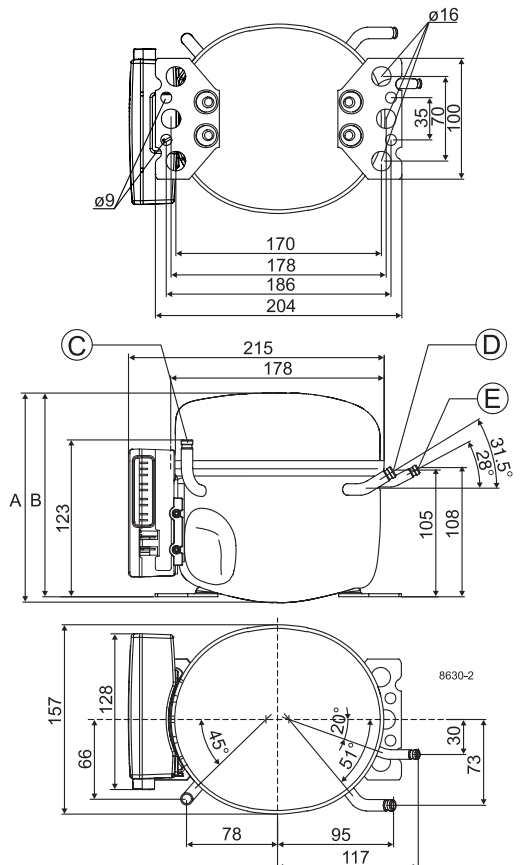

Capacity (EN 12900 Household/CECOMAF) 24V DC, fan cooling F₁ watt

rpm \ °C	-25	-23.3	-20	-15	-10	-6.7	-5	0	5	7.2	10	15
2,500	84.7	93.7	113	147	188	219	236	292	358	390	434	520
3,000	101	112	136	176	225	262	283	351	430	468	521	625
3,500	114	126	152	198	254	296	319	396	485	528	588	706
4,000	126	139	169	220	282	329	355	440	540	588	654	786

Capacity (ASHRAE LBP) 24V DC, fan cooling F₁ watt

rpm \ °C	-25	-23.3	-20	-15	-10	-6.7	-5	0	5	7.2	10	15
2,500	105	116	140	182	233	271	292	363	445	485	539	648
3,000	126	139	168	219	279	325	351	435	534	582	648	779
3,500	141	156	188	246	314	366	395	491	602	656	731	879
4,000	156	173	209	273	349	407	440	546	670	731	814	979

Power consumption 24V DC, fan cooling F₁ watt

rpm \ °C	-25	-23.3	-20	-15	-10	-6.7	-5	0	5	7.2	10	15
2,500	77.4	81.8	90.8	105	120	130	136	152	168	175	184	200
3,000	95.5	101	112	129	148	160	167	186	206	215	226	245
3,500	109	115	128	149	171	186	194	217	241	251	264	288
4,000	122	129	144	169	194	212	221	248	276	288	303	330

Current consumption 24V DC, fan cooling F₁ A

rpm \ °C	-25	-23.3	-20	-15	-10	-6.7	-5	0	5	7.2	10	15
2,500	3.23	3.41	3.78	4.38	5.01	5.43	5.66	6.32	7.00	7.29	7.67	8.33
3,000	3.98	4.20	4.66	5.39	6.15	6.67	6.95	7.76	8.58	8.94	9.40	10.21
3,500	4.52	4.79	5.34	6.21	7.12	7.75	8.08	9.05	10.03	10.46	11.01	11.98
4,000	5.07	5.38	6.02	7.03	8.10	8.82	9.20	10.34	11.48	11.99	12.63	13.75

COP (EN 12900 Household/CECOMAF) 24V DC, fan cooling F₁ W/W

rpm \ °C	-25	-23.3	-20	-15	-10	-6.7	-5	0	5	7.2	10	15
2,500	1.09	1.15	1.25	1.40	1.56	1.68	1.74	1.93	2.13	2.23	2.36	2.60
3,000	1.06	1.11	1.21	1.37	1.53	1.64	1.70	1.88	2.09	2.18	2.31	2.55
3,500	1.05	1.09	1.19	1.33	1.48	1.59	1.65	1.82	2.01	2.10	2.22	2.45
4,000	1.03	1.08	1.17	1.31	1.45	1.55	1.61	1.77	1.96	2.05	2.16	2.38

COP (ASHRAE LBP) 24V DC, fan cooling F₁ W/W

rpm \ °C	-25	-23.3	-20	-15	-10	-6.7	-5	0	5	7.2	10	15
2,500	1.36	1.42	1.55	1.74	1.95	2.09	2.17	2.40	2.67	2.79	2.95	3.27
3,000	1.32	1.38	1.51	1.70	1.90	2.04	2.12	2.35	2.61	2.73	2.89	3.20
3,500	1.30	1.36	1.48	1.66	1.85	1.98	2.05	2.27	2.52	2.63	2.79	3.08
4,000	1.28	1.34	1.45	1.62	1.81	1.93	2.00	2.22	2.45	2.56	2.71	2.99

Test conditions	EN 12900/CECOMAF	ASHRAE LBP
Condensing temperature	55°C	54.4°C
Ambient temperature	32°C	32°C
Suction gas temperature	32°C	32°C
Liquid temperature	no subcooling	32°C

Operational errors

Error code	Error type
	Can be read out in the software TOOL4COOL®
6	Thermostat failure (If the NTC thermistor is short-circuit or has no connection, the electronic unit will enter manual mode).
5	Thermal cut-out of electronic unit (If the refrigeration system has been too heavily loaded, or if the ambient temperature is high, the electronic unit will run too hot).
4	Minimum motor speed error (If the refrigeration system is too heavily loaded, the motor cannot maintain minimum speed at approximately 1,850 rpm).
3	Motor start error (The rotor is blocked or the differential pressure in the refrigeration system is too high).
2	Fan over-current cut-out (The evaporator fan loads the electronic unit with more than 1.8A _{peak} / the condenser fan loads the electronic unit with more than 2.5A _{peak}).
1	Battery protection cut-out (The voltage is outside the cut-out setting).

Accessories for BD350GH

Mounting	Code number
Bolt joint for one compressor Ø: 16 mm	118-1917
Bolt joint in quantities Ø: 16 mm	118-1918
Snap-on in quantities Ø: 16 mm	118-1919

Electrical (cables, sensors, etc.)	Code number	
	Single pack	I - Pack
Temperature sensor 470 mm	105N9612	105N9613, 200 pcs.
Temperature sensor 1000 mm	105N9614	105N9615, 100 pcs.
Temperature sensor 1500 mm	105N9616	105N9617, 100 pcs.
One Wire/LIN gateway	105N9501	-
Comm. cable, 1500 mm	-	105N9545, 100 pcs.
Comm. cable, 3000 mm	-	105N9547, 50 pcs.

Not deliverable from Secop	
Slow-blow fuse	30A
Main switch	rated to min. 50A

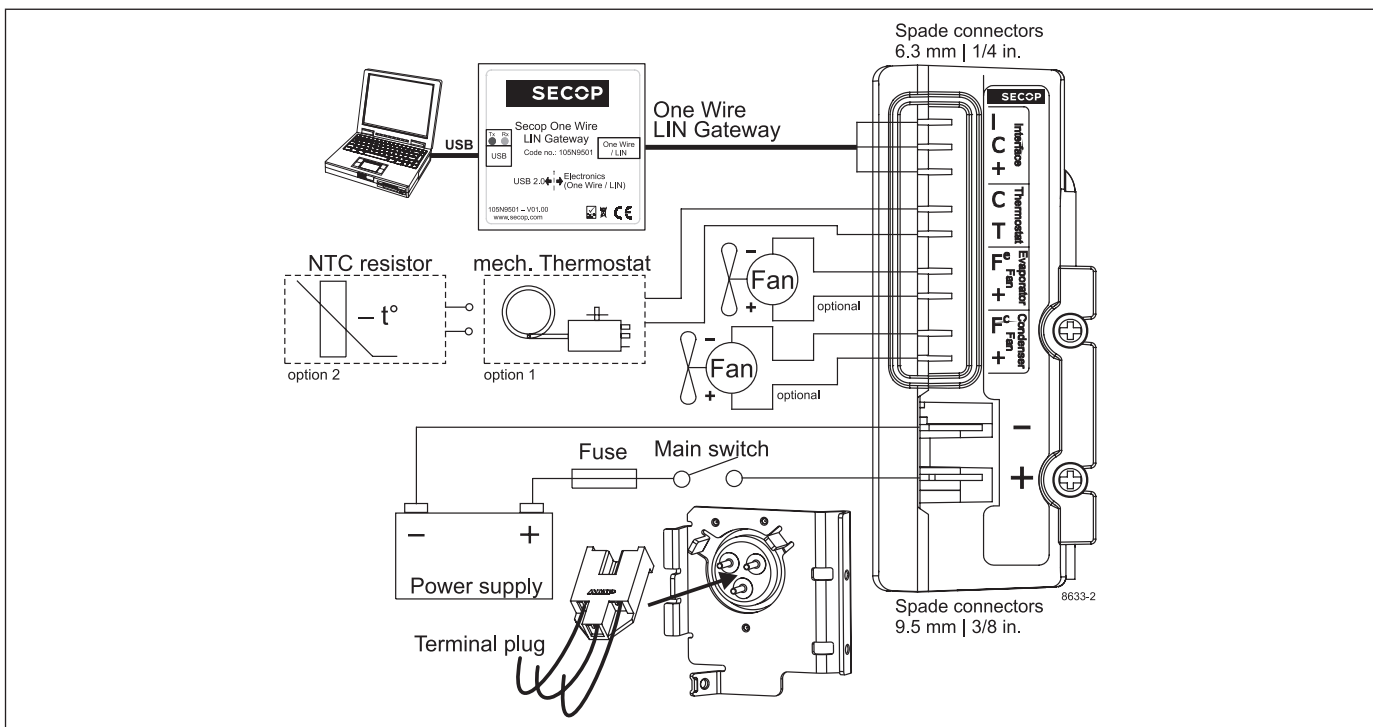

Secop accepts no responsibility for possible errors in catalogs, brochures, and other printed material. Secop reserves the right to alter its products without notice. This also applies to products already on order provided that such alterations can be made without consequential changes being necessary to specifications already agreed. All trademarks in this material are the property of the respective companies. Secop and the Secop logotype are trademarks of Secop GmbH. All rights reserved. www.secop.com

BD350GH Direct Current Compressor R134a 24V DC - with 101N08xx Series Controllers

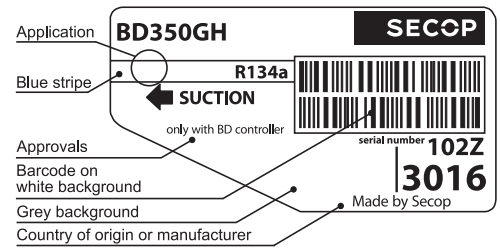

General

Code number (without electronic units)	102Z3016
Compressor module	101N0810, 30 pcs: 101N0811
Application module	101N0820, 30 pcs: 101N0821
Approvals	-
Compressors on pallet	125

Application

Application	LBP/MBP/HBP
Evaporating temperature °C	-25 to 15
Voltage range VDC	19 - 31.5
Max. condensing temperature continuous (short) °C	60 (70)
Max. winding temperature continuous (short) °C	125 (135)

- S = Static cooling normally sufficient
- O = Oil cooling
- F₁ = Fan cooling 1.5 m/s (compressor compartment temperature equal to ambient temperature)
- F₂ = Fan cooling 3.0 m/s necessary
- SG = Suction gas cooling normally sufficient
- = not applicable in this area

Cooling requirements

Application	LBP	MBP	HBP
32°C	F ₁	F ₁	F ₁
38°C	F ₁	F ₁	F ₁
43°C	F ₁	F ₁	F ₁

Remarks on application:
 - evaporator fan max. 200W
 - condenser fan max. 100W
 - starting ability: LST (low starting torque) only

Motor

Motor type	Variable speed
Resistance, all 3 windings (25°C) Ω	0.2

Design

Displacement cm ³	5.08
Oil quantity (type) cm ³	280 (polyolester)
Maximum refrigerant charge g	400
Free gas volume in compressor cm ³	1690
Weight - Compressor/Electronic unit kg	7.9 / 0.25 / 0.28 (101N820)

Battery protection settings

Voltage	Min. value	Default	Max. value
Cut out (0.1 steps) VDC	19.0	21.1	27.0
Cut in diff. (0.1 steps) VDC	0.5	3.9	10.0

Dimensions

Height mm	A	173
	B	169
	B1	-
	B2	-
Suction connector location/I.D. mm angle	C	6.2 90°
material comment		Cu-plated steel Al cap
Process connector location/I.D. mm angle	D	6.2 31.5°
material comment		Cu-plated steel Al cap
Discharge connector location/I.D. mm angle	E	5.0 28°
material comment		Cu-plated steel Al cap
Connector tolerance I.D. mm		±0.09, on 5.0 +0.12/+0.20

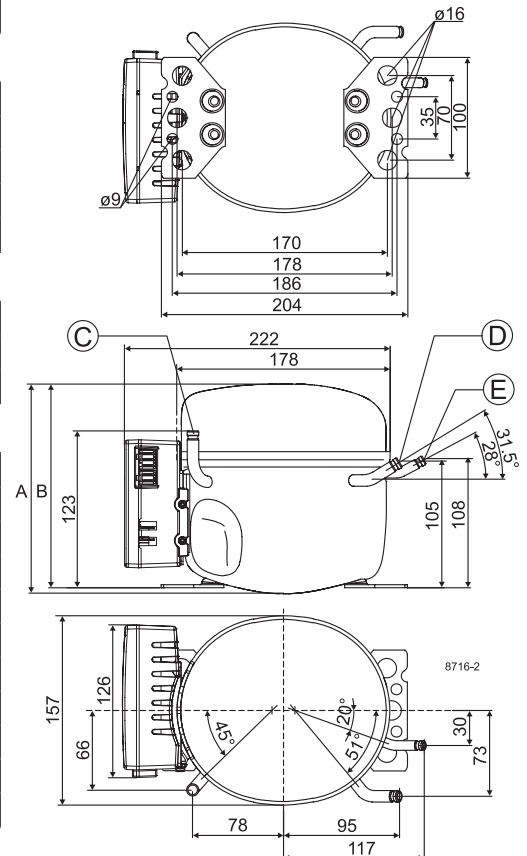

Capacity (EN 12900 Household/CECOMAF)												
24V DC, fan cooling F ₁ watt												
rpm \ °C	-25	-23.3	-20	-15	-10	-6.7	-5	0	5	7.2	10	15
2,500	84.7	93.7	113	147	188	219	236	292	358	390	434	520
3,000	101	112	136	176	225	262	283	351	430	468	521	625
3,500	114	126	152	198	254	296	319	396	485	528	588	706
4,000	126	139	169	220	282	329	355	440	540	588	654	786

Capacity (ASHRAE LBP)												
24V DC, fan cooling F ₁ watt												
rpm \ °C	-25	-23.3	-20	-15	-10	-6.7	-5	0	5	7.2	10	15
2,500	105	116	140	182	233	271	292	363	445	485	539	648
3,000	126	139	168	219	279	325	351	435	534	582	648	779
3,500	141	156	188	246	314	366	395	491	602	656	731	879
4,000	156	173	209	273	349	407	440	546	670	731	814	979

Power consumption												
24V DC, fan cooling F ₁ watt												
rpm \ °C	-25	-23.3	-20	-15	-10	-6.7	-5	0	5	7.2	10	15
2,500	77.4	81.8	90.8	105	120	130	136	152	168	175	184	200
3,000	95.5	101	112	129	148	160	167	186	206	215	226	245
3,500	109	115	128	149	171	186	194	217	241	251	264	288
4,000	122	129	144	169	194	212	221	248	276	288	303	330

Current consumption												
24V DC, fan cooling F ₁ A												
rpm \ °C	-25	-23.3	-20	-15	-10	-6.7	-5	0	5	7.2	10	15
2,500	3.23	3.41	3.78	4.38	5.01	5.43	5.66	6.32	7.00	7.29	7.67	8.33
3,000	3.98	4.20	4.66	5.39	6.15	6.67	6.95	7.76	8.58	8.94	9.40	10.21
3,500	4.52	4.79	5.34	6.21	7.12	7.75	8.08	9.05	10.03	10.46	11.01	11.98
4,000	5.07	5.38	6.02	7.03	8.10	8.82	9.20	10.34	11.48	11.99	12.63	13.75

COP (EN 12900 Household/CECOMAF)												
24V DC, fan cooling F ₁ W/W												
rpm \ °C	-25	-23.3	-20	-15	-10	-6.7	-5	0	5	7.2	10	15
2,500	1.09	1.15	1.25	1.40	1.56	1.68	1.74	1.93	2.13	2.23	2.36	2.60
3,000	1.06	1.11	1.21	1.37	1.53	1.64	1.70	1.88	2.09	2.18	2.31	2.55
3,500	1.05	1.09	1.19	1.33	1.48	1.59	1.65	1.82	2.01	2.10	2.22	2.45
4,000	1.03	1.08	1.17	1.31	1.45	1.55	1.61	1.77	1.96	2.05	2.16	2.38

COP (ASHRAE LBP)												
24V DC, fan cooling F ₁ W/W												
rpm \ °C	-25	-23.3	-20	-15	-10	-6.7	-5	0	5	7.2	10	15
2,500	1.36	1.42	1.55	1.74	1.95	2.09	2.17	2.40	2.67	2.79	2.95	3.27
3,000	1.32	1.38	1.51	1.70	1.90	2.04	2.12	2.35	2.61	2.73	2.89	3.20
3,500	1.30	1.36	1.48	1.66	1.85	1.98	2.05	2.27	2.52	2.63	2.79	3.08
4,000	1.28	1.34	1.45	1.62	1.81	1.93	2.00	2.22	2.45	2.56	2.71	2.99

Test conditions	EN 12900/CECOMAF	ASHRAE LBP
Condensing temperature	55°C	54.4°C
Ambient temperature	32°C	32°C
Suction gas temperature	32°C	32°C
Liquid temperature	no subcooling	32°C

Error code	Error type
	Can be read out in the software TOOL4COOL®
6	Thermostat failure (If the NTC thermistor is short-circuit or has no connection, the electronic unit will enter manual mode).
5	Thermal cut-out of electronic unit (If the refrigeration system has been too heavily loaded, or if the ambient temperature is high, the electronic unit will run too hot).
4	Minimum motor speed error (If the refrigeration system is too heavily loaded, the motor cannot maintain minimum speed at approximately 1,850 rpm).
3	Motor start error (The rotor is blocked or the differential pressure in the refrigeration system is too high).
2	Fan over-current cut-out (The fan loads the electronic unit with too high current).
1	Battery protection cut-out (The voltage is outside the cut-out setting).

Accessories for BD350GH	
Mounting	Code number
Bolt joint for one compressor Ø: 16 mm	118-1917
Bolt joint in quantities Ø: 16 mm	118-1918
Snap-on in quantities Ø: 16 mm	118-1919

Electrical (cables, sensors, etc.)	Code number	
	Single pack	I - Pack
One Wire/LIN gateway communication cable	105N9501	-
Bluetooth® gateway communication cable	105N9502	-
Temperature sensor 470 mm	105N9612	105N9613, 200 pcs.
Temperature sensor 1000 mm	105N9614	105N9615, 100 pcs.
Temperature sensor 1500 mm	105N9616	105N9617, 100 pcs.
Comm. cable, 1500 mm	-	105N9553, 80 pcs.
Comm. cable, 3000 mm	-	105N9554, 45 pcs.
Display cable, 1500 mm	-	105N9557, 65 pcs.
Display cable, 3000 mm	-	105N9558, 35 pcs.

Not deliverable from Secop	
Slow-blow fuse compressor module	60A
Slow-blow fuse application module	30A
Main switch	rated to min. 100A

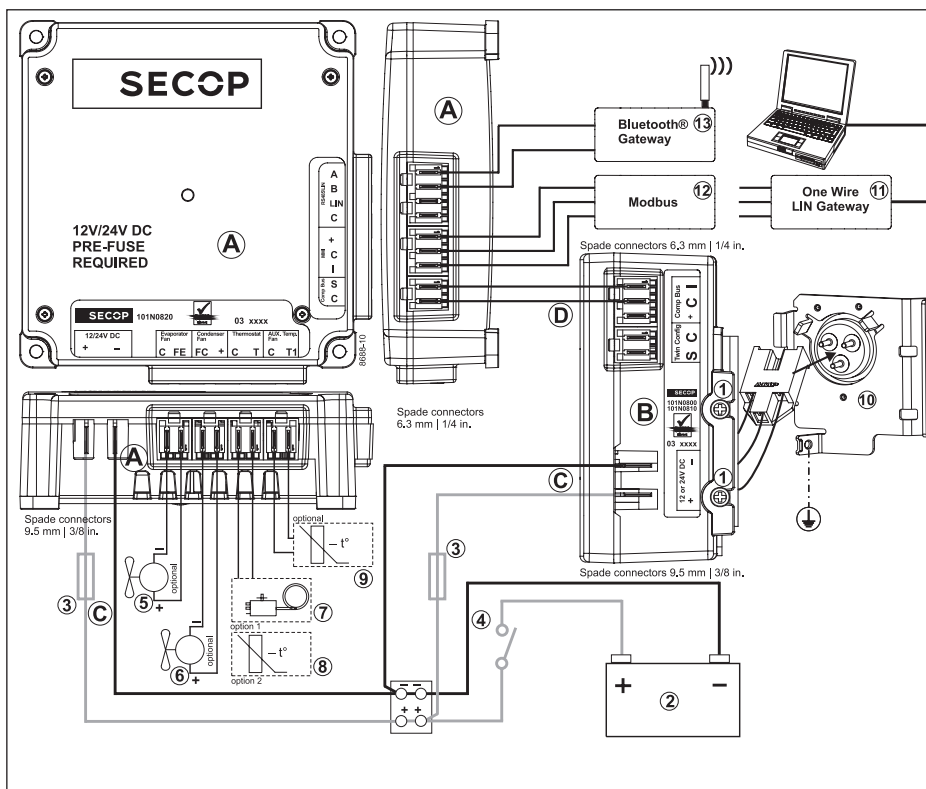

Legend, see **Intructions** for details.

- A) Application module **101N0820**
 - B) Compressor module **101N0810**, 24 V DC
 - C) Supply cables
 - D) Compressor communication cable assembly
- 1) Mounting screws
 - 2) Battery
 - 3) Fuse
 - 4) Main switch
 - 5) Evaporator fan
 - 6) Condenser fan
 - 7) Mechanical thermostat
 - 8) NTC temperature sensor
 - 9) NTC auxiliary temperature sensor
 - 10) Compressor(s)
 - 11) One Wire/LIN gateway comm. interface
 - 12) Modbus-compatible device
 - 13) Bluetooth® gateway comm. interface

Secop accepts no responsibility for possible errors in catalogs, brochures, and other printed material. Secop reserves the right to alter its products without notice. This also applies to products already on order provided that such alterations can be made without consequential changes being necessary to specifications already agreed. All trademarks in this material are the property of the respective companies. Secop and the Secop logotype are trademarks of Secop GmbH. All rights reserved. www.secop.com



Instructions for Electronic Units
are available for download on
www.secop.com



BD Compressors



Service/Repair

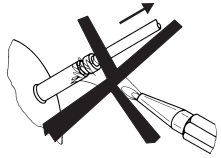

8545

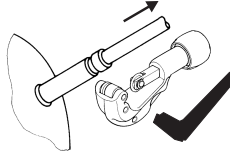

R290



R600a



R170



R1234yf

BD Nano

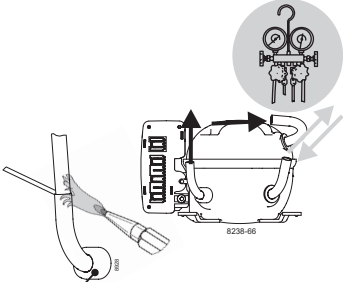

8238-66

**! max. 150°C/302°F !
at socket**

brazing solder: silver with flux

Do not heat up the bottom of the discharge connector directly.
Do not braise longer than 10 seconds and wait for 5 minutes for the next soldering attempt (Product Bulletin DES.N.101.M1).

BD Micro

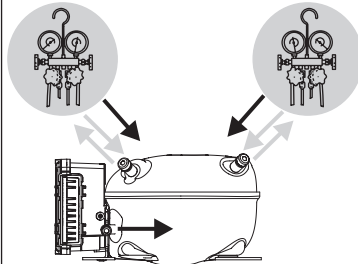

8238-47

BD P-Housing

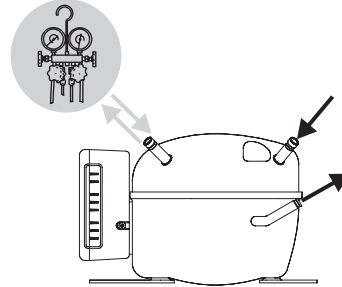

8238-31

BD T-Housing

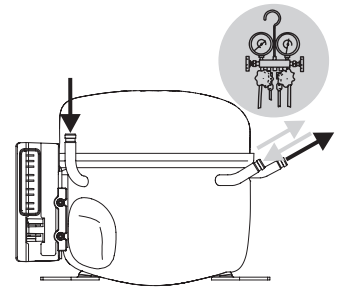

8238-48

Secop accepts no responsibility for possible errors in catalogs, brochures, and other printed material. Secop reserves the right to alter its products without notice. This also applies to products already on order provided that such alterations can be made without subsequent changes being necessary to specifications already agreed. All trademarks in this material are the property of the respective companies. Secop and the Secop logotype are trademarks of Secop GmbH. All rights reserved. www.secop.com