

Single Pack TL3F 220-240V 50Hz CSIR

Single pack code number: **195B4212**

Position	Title	Code	Amount
1	Compressor TL3F	102G4300	1
2	Starting relay	117U6007	1
3	Starting capacitor (60 μ F 220V, 6.3mm)	117U5014	1
4	Cord relief	103N1010	1
5	Cover	103N2010	1
6	Bolt joint for one compressor M6 \varnothing 16mm	118-1917	1

Secop GmbH • Lise-Meitner-Straße 29 • 24941 Flensburg, Germany • Tel: +49 461 4941 0 • www.secop.com

Secop accepts no responsibility for possible errors in catalogs, brochures, and other printed material. Secop reserves the right to alter its products without notice. This also applies to products already on order provided that such alterations can be made without subsequent changes being necessary to specifications already agreed. All trademarks in this material are the property of the respective companies. Secop and the Secop logotype are trademarks of Secop GmbH. All rights reserved.

TL3F Standard Compressor R134a 220-240V 50Hz

General

Code number	102G4300
Approvals	EN 60335-2-34 w. Annex AA, CCC
Compressors on pallet	125

Application

Application	MBP		
Frequency	Hz	50	60
Evaporating temperature	°C	-25 to 0	-
Voltage range	V	198 - 254	-
Max. condensing temperature continuous (short)	°C	60 (70)	-
Max. winding temperature continuous (short)	°C	125 (135)	-

Cooling requirements

Frequency	Hz	50			60		
Application		LBP	MBP	HBP	LBP	MBP	HBP
32°C		-	S	-	-	-	-
38°C		-	S	-	-	-	-
43°C		-	-	-	-	-	-
Remarks on application:							

Motor

Motor type	RSIR/CSIR		
LRA (rated after 4 sec. UL984), HST LST	A	4.5	2.8
Cut in Current, HST LST	A	4.5	7.5
Resistance, main start winding (25°C)	Ω	31.5	15.0

Design

Displacement	cm ³	3.13
Oil quantity (type)	cm ³	180 (polyolester)
Maximum refrigerant charge	g	400
Free gas volume in compressor	cm ³	1600
Weight without electrical equipment	kg	6.7

Dimensions

Height	mm	A	163
		B	159
		B1	-
		B2	-
Suction connector	location/I.D. mm angle	C	6.2 30°
	material comment		Cu-plated steel Al cap
Process connector	location/I.D. mm angle	D	6.2 31.5°
	material comment		Cu-plated steel Al cap
Discharge connector	location/I.D. mm angle	E	5.0 28°
	material comment		Cu-plated steel Al cap
Oil cooler connector	location/I.D. mm angle	F	-
	material comment		-
Connector tolerance	I.D. mm		±0.09, on 5.0 +0.12/+0.20
Remarks:			

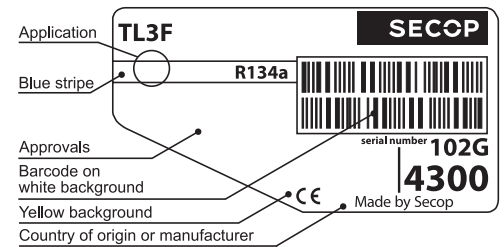

- S = Static cooling normally sufficient
- O = Oil cooling
- F₁ = Fan cooling 1.5 m/s
(compressor compartment temperature equal to ambient temperature)
- F₂ = Fan cooling 3.0 m/s necessary
- SG = Suction gas cooling normally sufficient
- = not applicable in this area

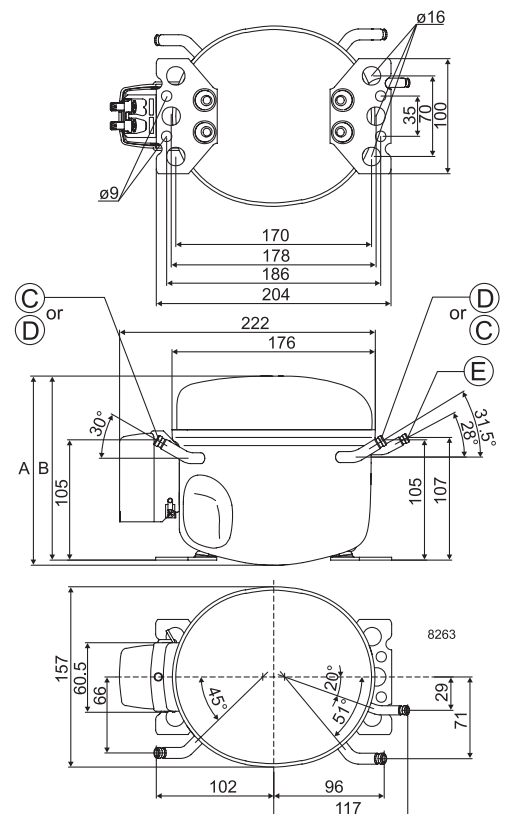

EN 12900 Household (CECOMAF) 220V, 50Hz, static cooling, PTC consumption incl.

Evap. temp in °C	-45	-40	-35	-30	-25	-23.3	-20	-15	-10	-6.7	-5	0	5	7.2	10	15	20
Capacity in W					42	48	60	82	108	127	138	173					
Power cons. in W					66	69	76	87	99	107	111	124					
Current cons. in A					0.50	0.51	0.52	0.54	0.57	0.6	0.61	0.67					
COP in W/W					0.64	0.69	0.79	0.94	1.09	1.19	1.24	1.39					

ASHRAE LBP 220V, 50Hz, static cooling, PTC consumption incl.

Evap. temp in °C	-45	-40	-35	-30	-25	-23.3	-20	-15	-10	-6.7	-5	0	5	7.2	10	15	20
Capacity in W					52	59	74	101	133	158	171	214					
Power cons. in W					66	69	76	87	99	107	111	124					
Current cons. in A					0.50	0.51	0.52	0.54	0.57	0.6	0.61	0.67					
COP in W/W					0.78	0.85	0.97	1.16	1.35	1.48	1.53	1.72					



Accessories for	TL3F	Figure	Code number
PTC starting device	6.3 mm spade connectors	a1	103N0011
	4.8 mm spade connectors		103N0018
Starting relay	6.3 mm spade connectors	a2	117U6007
Start capacitor 60 µF	6.3 mm spade connectors	c	117U5014
Cover		b	103N2010
Cord relief		d	103N1010
Protection screen for PTC		g	103N0476

Test conditions	EN 12900/ CECOMAF	ASHRAE
Condensing temperature	55°C	55°C
Ambient temperature	32°C	32°C
Suction gas temperature	32°C	32°C
Liquid temperature	no subcooling	32°C

Mounting accessories	Code number	
Bolt joint for one comp.	Ø: 16 mm	118-1917
Bolt joint in quantities	Ø: 16 mm	118-1918
Snap-on in quantities	Ø: 16 mm	118-1919

Secop accepts no responsibility for possible errors in catalogs, brochures, and other printed material. Secop reserves the right to alter its products without notice. This also applies to products already on order provided that such alterations can be made without consequential changes being necessary to specifications already agreed. All trademarks in this material are the property of the respective companies. Secop and the Secop logotype are trademarks of Secop GmbH. All rights reserved. www.secop.com



TL Compressors





Service/Repair – R600a, R290



8545

Brazing on Suction Connectors (Direct Intake)

representative image



! max. 150°C/302°F !
at socket
 brazing solder: phosphor (LP7) or silver

Refer to Product Bulletin:
Brazing on Suction Connectors
(Compressors with Direct Suction Intake)

Secop accepts no responsibility for possible errors in catalogs, brochures, and other printed material. Secop reserves the right to alter its products without notice. This also applies to products already on order provided that such alterations can be made without subsequential changes being necessary to specifications already agreed. All trademarks in this material are the property of the respective companies. Secop and the Secop logotype are trademarks of Secop GmbH. All rights reserved. www.secop.com