

Single Pack SC15GHH 220-240V 50Hz CSCR

Single pack code number: **195B4271**

Position	Title	Code	Amount
1	Compressor SC15GHH	104G8571	1
2	SC starting device (550mm)	117-7027	1
3	Cord relief	103N1004	1
4	Cover	103N2009	1
5	Bolt joint for one compressor M6 ø16mm	118-1917	1

Secop GmbH • Lise-Meitner-Straße 29 • 24941 Flensburg, Germany • Tel: +49 461 4941 0 • www.secop.com

Secop accepts no responsibility for possible errors in catalogs, brochures, and other printed material. Secop reserves the right to alter its products without notice. This also applies to products already on order provided that such alterations can be made without subsequent changes being necessary to specifications already agreed. All trademarks in this material are the property of the respective companies. Secop and the Secop logotype are trademarks of Secop GmbH. All rights reserved.

Model

Designation	SC15GHH	220-240V/50Hz 1~	Sales code:	104G8571
-------------	----------------	------------------	-------------	-----------------

Compressor design

Oil type	Polyolester	Refrigerant(s)	R134a
Oil viscosity	22cST	Displacement	15,28cm ³ / 0,93cu.in
Oil quantity	449cm ³ / 15,2fl.oz	Compressors on pallet	80
Refr. charge - tech. limit	1300g / 45,9oz		
Free gas volume comp.	1540cm ³ / 52,1fl.oz		
Weight	13kg / 28,7lbs		
Motor protection	1# internal		
Winding resistance main	5,13Ω (at 25°C)		
Winding resistance aux	13,51Ω (at 25°C)		
Max. winding temp.	125°C / 257°F		
Max. discharge temp.	135°C / 275°F		



General - Configurations with SC15GHH

	Conf. 1
Motorconfiguration	CSCR
Power supply (nominal)	220-240V/50Hz
Number of phases	1
Voltage range	198-254V
Approvals	VDE
Starting torque	HST
Note	- / -

Applications with SC15GHH

	Conf. 1
Refrigerant	R134a
Application	HBP
System cooling	oil cooled
Hot gas defrost	OK
Long interval pull down	OK

Electrical data - Configurations with SC15GHH

	Conf. 1
Starting device type	relay
Run capacitor	10μF
Start capacitor	80μF
LRA (locked rotor amps / 4s)	
RLA (rated load amps / 1s)	-/A
Cut in current	

Model

Designation

SC15GHH

220-240V/50Hz 1~

Sales code:

104G8571

Compressor dimensions

Housing	A Height	209mm / 8,23in
	B Height	203mm / 7,99in
	C Length shell	218mm / 8,58in
	D Length w. cover	255mm / 10,04in
	E Width	151mm / 5,94in

Connectors	Suction X	Discharge Y	Process Z
Diameter [mm]	øi 10,11-10,29	øi 8,11-8,29	øi 6,11-6,29
(i:inside, o:outside) [in]	øi 0,4-0,41	øi 0,32-0,33	øi 0,24-0,25
Material	copper	copper	copper
Horizontal angle ±2°	37°	37°	143°
Vertical angle ±2°	30°	0°	150°
Position l/h/w [mm]	107/183/55	115/100/63	-107/183/55
[in]	4,2/7,2/2,2	4,5/3,9/2,5	-4,2/7,2/2,2
Straight tube l. [mm]	12	12	12
[in]	0,5	0,5	0,5



Compressor fixation



Bolt joint



Snap-on



Mounting accessories

Mounting accessories	one comp.	multi pack
Bolt joint M6 ø16mm	118-1917	118-1918
Bolt joint ø1/4" ø16mm	118-1946	
Bolt joint ø1/4" ø19mm	118-1949	
Snap-on ø7,3 ø16mm	118-1947	118-1919

Application notes

Provision for PE Grounding is located at the PE Stamp on the compressor

Model

Designation	SC15GHH	220-240V/50Hz	Conf. 1	Sales code:	104G8571
-------------	----------------	----------------------	----------------	-------------	-----------------

Configuration

Motorconfiguration	CSCR
Power supply (nominal)	220-240V/50Hz 1~
Refrigerant	R134a
Application	HBP
Voltage range	198-254V
Starting torque	HST
Approvals	VDE

Electrical accessories / wiring diagram

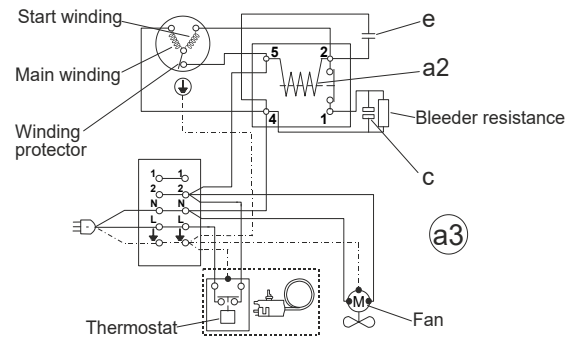
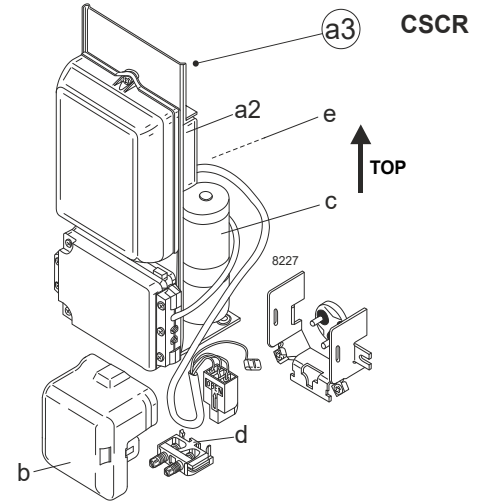

Ambient/ machine room temperatures minimum /maximum

Ambient temperature range:	10 - 43°C / 50 - 110°F
Machine room temperature range:	10 - 48°C / 50 - 119°F
Compressor cooling:	fan 1,5m/s

Operation Limits

Operation pressure range

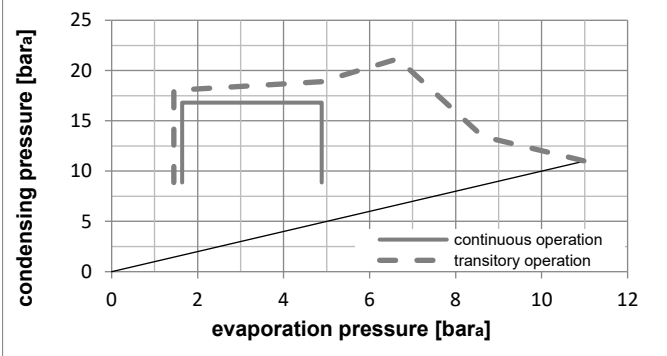
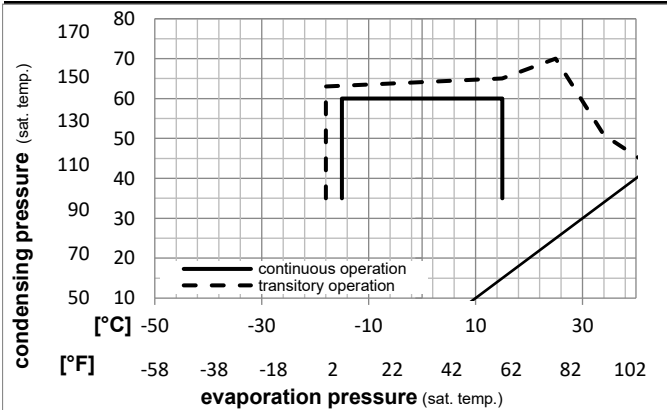

Components

a3	SC starter kit (550mm)	117-7027
b	plastic cover	103N2009
d	cord relief	103N1004

Model

Designation **SC15GHH** **220-240V/50Hz** Conf. 1 Sales code: **104G8571**

Optimization + standard conditions

R134a, 220V/50Hz, CSCR, fan 1,5m/s, VDE

		Evaporating pressure (saturation temperature)				Condensing pressure (saturation temperature)			Return gas temp.			Liquid temp.			Cooling capacity			COP	EER	Power consumption			
		pe	pc	RGT	Tliq	[W]	[Btu/h]	[kcal/h]	[W/W]	[Btu/Wh]	[kcal/Wh]	P1	I	Ref. mass flow									
[°C]	[°F]											[W]	[A]	[kg/h]									
7,2	45	54	35	46	1383,1	4723	1190,3	2,66	9,07	2,29	520,8	2,46	30,68	ASHRAE HBP									
5	41	55	32	55	1134,9	3876	976,7	2,25	7,68	1,93	504,8	2,39	27,97	cecomaf HBP									
5	41	50	20	50	1168,7	3991	1005,8	2,40	8,19	2,06	487,2	2,31	29,45	EN12900 HBP									
-7	20	54	35	46	740,5	2529	637,3	1,84	6,28	1,58	402,5	1,94	16,16	ASHRAE MBP									
-10	14	55	32	55	570,1	1947	490,6	1,51	5,16	1,30	377,0	1,84	13,79	cecomaf MBP									
-10	14	45	20	45	636,4	2173	547,7	1,74	5,94	1,50	366,0	1,79	14,90	EN12900 MBP									

Performance tables

R134a, 220V/50Hz, CSCR, fan 1,5m/s, VDE

	pe		Cooling capacity			COP	EER	P1	I	m	
	[°C]	[°F]	[W]	[Btu/h]	[kcal/h]	[W/W]	[Btu/Wh]	[kcal/Wh]	[W]	[A]	[kg/h]
[°C / °F]	-15	5	489,2	1671	421,0	1,44	4,91	1,24	340,4	1,69	10,66
cond. pressure	-10	14	660,2	2255	568,2	1,80	6,16	1,55	366,0	1,79	14,45
pc= 45/113	-5	23	852,0	2910	733,2	2,14	7,30	1,84	398,6	1,93	18,73
return gas temp.	0	32	1073,0	3665	923,5	2,47	8,44	2,13	434,0	2,08	23,73
RGT= 32/90	5	41	1332,1	4549	1146,4	2,85	9,73	2,45	467,5	2,23	29,66
liquid temp	10	50	1637,9	5594	1409,6	3,31	11,30	2,85	494,8	2,35	36,75
Tliq= 45/113	15	59	1998,9	6827	1720,3	3,91	13,35	3,36	511,4	2,42	45,28
[°C / °F]	-15	5	434,9	1485	374,3	1,26	4,30	1,08	345,3	1,71	10,47
cond. pressure	-10	14	570,1	1947	490,6	1,51	5,16	1,30	377,0	1,84	13,79
pc= 55/131	-5	23	726,1	2480	624,9	1,74	5,94	1,50	417,1	2,01	17,65
return gas temp	0	32	911,4	3113	784,4	1,98	6,75	1,70	461,2	2,20	22,29
RGT= 32/90	5	41	1134,9	3876	976,7	2,25	7,68	1,93	504,8	2,39	27,97
liquid temp	10	50	1405,0	4798	1209,2	2,59	8,83	2,22	543,5	2,56	34,93
Tliq= 55/131	15	59	1730,6	5910	1489,4	3,02	10,32	2,60	572,8	2,70	43,47



SC Compressors





SC Compressors

Service/Repair – R290



8545



Secop accepts no responsibility for possible errors in catalogs, brochures, and other printed material. Secop reserves the right to alter its products without notice. This also applies to products already on order provided that such alterations can be made without subsequent changes being necessary to specifications already agreed. All trademarks in this material are the property of the respective companies. Secop and the Secop logotype are trademarks of Secop GmbH. All rights reserved. www.secop.com