

Single Pack DLV4.0CN 100-127V 50/60Hz PM

Single pack code number: **195B4329**

Position	Title	Code	Amount
1	Compressor DLV4.0CN	102H3486	1
2	Motor cable (900mm)	105B4477	1
3	Electronic unit DLV	105N4460	1
4	Cord relief	103N1010	1
5	Bolt joint for one compressor M6 ø16mm	118-1917	1

DLV4.0CN Variable Speed Drive Compressor R290, 100-127V 50/60Hz

- with 105N4460 Controller



General

Code number (without electronic unit)	102H3486
Electronic unit	105N4460
Approvals: UL 60335-2-34 with Annex AA, CCC	
Compressors on pallet	100

Application

Application	LBP/MBP			
Frequency	Hz	50	60	
Evaporating temperature	°F	-31 to 45	-31 to 45	
Voltage range	V	90 - 140	90 - 140	
Max. condensing temperature continuous (short)	°F	140 (149)	140 (149)	
Max. winding temperature continuous (short)	°F	257 (275)	257 (275)	

Cooling requirements

Frequency	Hz	50			60		
Application		LBP	MBP	HBP	LBP	MBP	HBP
32°C		F ₂	F ₂	-	F ₂	F ₂	-
38°C		F ₂	F ₂	-	F ₂	F ₂	-
43°C		F ₂	F ₂	-	F ₂	F ₂	-

Remarks on application:

Features

Speed range	rpm	2000 - 4500
Speed control		AEO, frequency, serial com.
Thermostat		integrated, electronic
Protections		current, speed, temperature
Protection class (electronic unit)		IP54

Motor

Motor type		permanent magnet
LRA (rated after 4 sec. UL984)	A	electronic cut off
Maximum current	A	6.5
Resistance, all 3 windings (25°C)	Ω	1.2

Design

Displacement	cu.in	0.24
Oil quantity (type)	fl.oz.	7.8 (polyolester)
Maximum refrigerant charge	oz.	5.3
Free gas volume in compressor	fl.oz.	49.5
Weight - Compressor/Electronic unit	lbs.	17.2 / 1.15

Dimensions

Height	inch	A	6.89
		B	6.65
Suction connector	location/I.D. mm angle	C	0.320-0.327 18°
	material comment		Copper Rubber plug
Process connector	location/O.D. mm angle	D	0.252-0.259 61°
	material comment		Copper Rubber plug
Discharge connector	location/O.D. mm angle	E	0.252-0.259 25°
	material comment		Copper Rubber plug

Accessories

	Code number
Cover	103N0492
Cord relief	103N1010
Motor cable	35.4 in. cable length 105B4477

Mounting accessories

	Code number
Bolt joint for one compressor	Ø: 3/4 in. 118-1949
Bolt joint in quantities	Ø: 5/8 in. 118-1946
Snap-on in quantities	Ø: 5/8 in. 118-1947

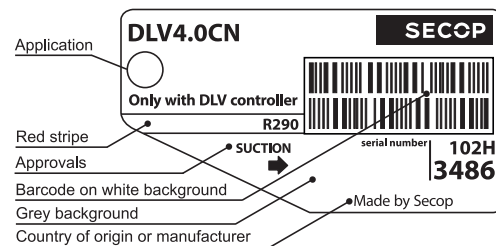

- S = Static cooling normally sufficient
- O = Oil cooling
- F₁ = Fan cooling 1.5 m/s (compressor compartment temperature equal to ambient temperature)
- F₂ = Fan cooling 3.0 m/s necessary
- = not applicable in this area

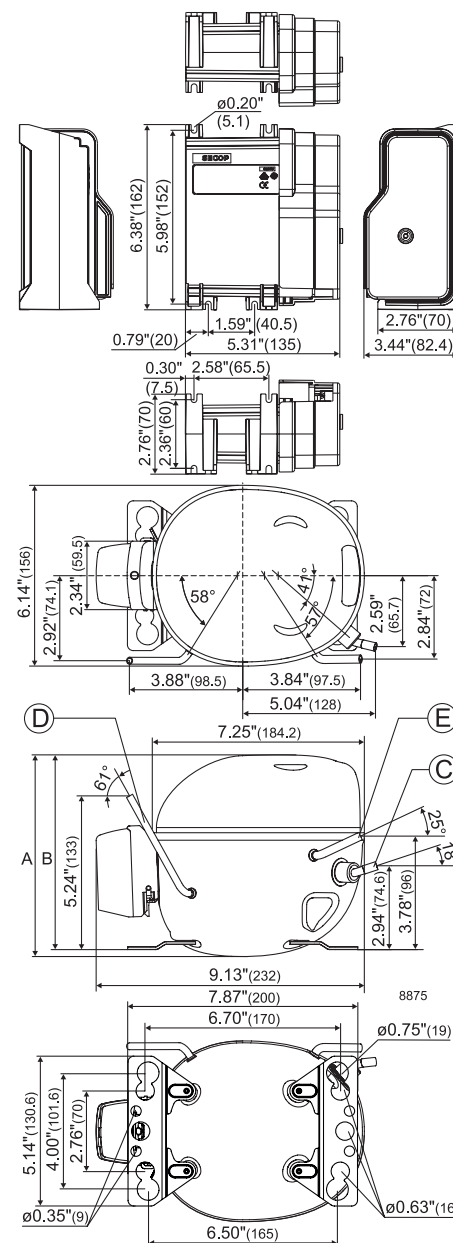

LBP: ASHRAE 115V, 50/60Hz, fan cooling F₂

Speed (rpm)	2000	2250	2500	2750	3000	3500	4000	4500
Capacity [BTU/h]	409	465	522	577	632	741	849	958
Power cons. [W]	77.6	87.6	97.5	107.1	116.7	137.0	157.3	177.5
Current cons. [A]	1.07	1.25	1.42	1.60	1.79	2.23	2.68	3.12
EER [BTU/Wh]	5.27	5.31	5.35	5.38	5.42	5.41	5.40	5.39

Test conditions

Evaporation pressure	-10°F	-23.3°C
Condensing pressure	130°F	54.4°C
Liquid temperature	90°F	32.2°C
Return gas temperature	90°F	32.2°C

LBP: CECOMAF 115V, 50/60Hz, fan cooling F₂

Speed (rpm)	2000	2250	2500	2750	3000	3500	4000	4500
Capacity [BTU/h]	302	343	385	425	466	546	626	706
Power cons. [W]	75.0	84.3	93.6	102.9	112.2	131.6	151.1	170.6
Current cons. [A]	1.03	1.19	1.35	1.52	1.70	2.12	2.54	2.95
EER [BTU/Wh]	4.02	4.07	4.11	4.13	4.16	4.15	4.14	4.14

Test conditions

Evaporation pressure	-13°F	-25°C
Condensing pressure	131°F	55°C
Liquid temperature	131°F	55°C
Return gas temperature	90°F	32°C

LBP: EN12900 115V, 50/60Hz, fan cooling F₂

Speed (rpm)	2000	2250	2500	2750	3000	3500	4000	4500
Capacity [BTU/h]	222	252	283	313	342	401	460	519
Power cons. [W]	58.1	63.0	68.0	75.2	82.4	96.6	110.8	124.9
Current cons. [A]	0.76	0.84	0.92	1.03	1.15	1.42	1.68	1.95
EER [BTU/Wh]	3.81	4.00	4.16	4.16	4.16	4.16	4.15	4.15

Test conditions

Evaporation pressure	-31°F	-35°C
Condensing pressure	104°F	40°C
Liquid temperature	104°F	40°C
Return gas temperature	68°F	20°C

MBP: ASHRAE 115V, 50/60Hz, fan cooling F₂

Speed (rpm)	2000	2250	2500	2750	3000	3500	4000	4500
Capacity [BTU/h]	783	891	999	1105	1210	1418	1626	1834
Power cons. [W]	103.1	118.3	133.5	146.4	159.3	186.9	214.6	242.2
Current cons. [A]	1.52	1.82	2.12	2.40	2.68	3.40	4.11	4.83
EER [BTU/Wh]	7.60	7.53	7.48	7.54	7.60	7.59	7.58	7.57

Test conditions

Evaporation pressure	20°F	-6.7°C
Condensing pressure	130°F	54.4°C
Liquid temperature	115°F	46.1°C
Return gas temperature	95°F	35°C

MBP: CECOMAF 115V, 50/60Hz, fan cooling F₂

Speed (rpm)	2000	2250	2500	2750	3000	3500	4000	4500
Capacity [BTU/h]	616	700	785	869	952	1115	1278	1442
Power cons. [W]	99.0	113.4	127.9	140.2	152.6	179.0	205.5	232.0
Current cons. [A]	1.45	1.73	2.01	2.27	2.54	3.20	3.87	4.54
EER [BTU/Wh]	6.22	6.18	6.14	6.19	6.24	6.23	6.22	6.21

Test conditions

Evaporation pressure	14°F	-10°C
Condensing pressure	131°F	55°C
Liquid temperature	131°F	55°C
Return gas temperature	90°F	32°C

MBP: EN12900 115V, 50/60Hz, fan cooling F₂

Speed (rpm)	2000	2250	2500	2750	3000	3500	4000	4500
Capacity [BTU/h]	694	790	885	979	1073	1257	1441	1625
Power cons. [W]	89.7	102.3	115.0	126.1	137.3	161.1	185.0	208.8
Current cons. [A]	1.28	1.51	1.75	1.97	2.20	2.77	3.33	3.90
EER [BTU/Wh]	7.74	7.72	7.70	7.76	7.82	7.80	7.79	7.78

Test conditions

Evaporation pressure	14°F	-10°C
Condensing pressure	113°F	45°C
Liquid temperature	113°F	45°C
Return gas temperature	68°F	20°C

Optimization Point 115V, 50/60Hz, fan cooling F₂

Speed (rpm)	2000	2250	2500	2750	3000	3500	4000	4500
Capacity [BTU/h]	428	487	546	604	661	775	889	1002
Power cons. [W]	67.9	75.5	83.2	91.5	99.9	117.2	134.5	151.8
Current cons. [A]	0.91	1.04	1.16	1.31	1.46	1.81	2.16	2.51
EER [BTU/Wh]	6.30	6.45	6.56	6.59	6.62	6.61	6.60	6.60

Test conditions

Evaporation pressure	-13°F	-25°C
Condensing pressure	95°F	35°C
Liquid temperature	95°F	35°C
Return gas temperature	90°F	32°C

Optimization Point 115V, 50/60Hz, fan cooling F₂

Speed (rpm)	2000	2250	2500	2750	3000	3500	4000	4500
Capacity [BTU/h]	722	822	922	1019	1117	1309	1500	1692
Power cons. [W]	89.7	102.3	115.0	126.1	137.3	161.1	185.0	208.8
Current cons. [A]	1.28	1.51	1.75	1.97	2.20	2.77	3.33	3.90
EER [BTU/Wh]	8.06	8.03	8.01	8.08	8.14	8.12	8.11	8.10

Test conditions

Evaporation pressure	14°F	-10°C
Condensing pressure	113°F	45°C
Liquid temperature	113°F	45°C
Return gas temperature	90°F	32°C

Optimization Point 115V, 50/60Hz, fan cooling F₂

Speed (rpm)	2000	2250	2500	2750	3000	3500	4000	4500
Capacity [BTU/h]	1267	1441	1616	1787	1958	2294	2630	2966
Power cons. [W]	100.6	115.4	130.1	142.7	155.3	182.2	209.2	236.1
Current cons. [A]	1.48	1.76	2.05	2.32	2.60	3.28	3.97	4.66
EER [BTU/Wh]	12.59	12.49	12.42	12.52	12.61	12.59	12.58	12.56

Test conditions

Evaporation pressure	41°F	5°C
Condensing pressure	113°F	45°C
Liquid temperature	113°F	45°C
Return gas temperature	90°F	32°C

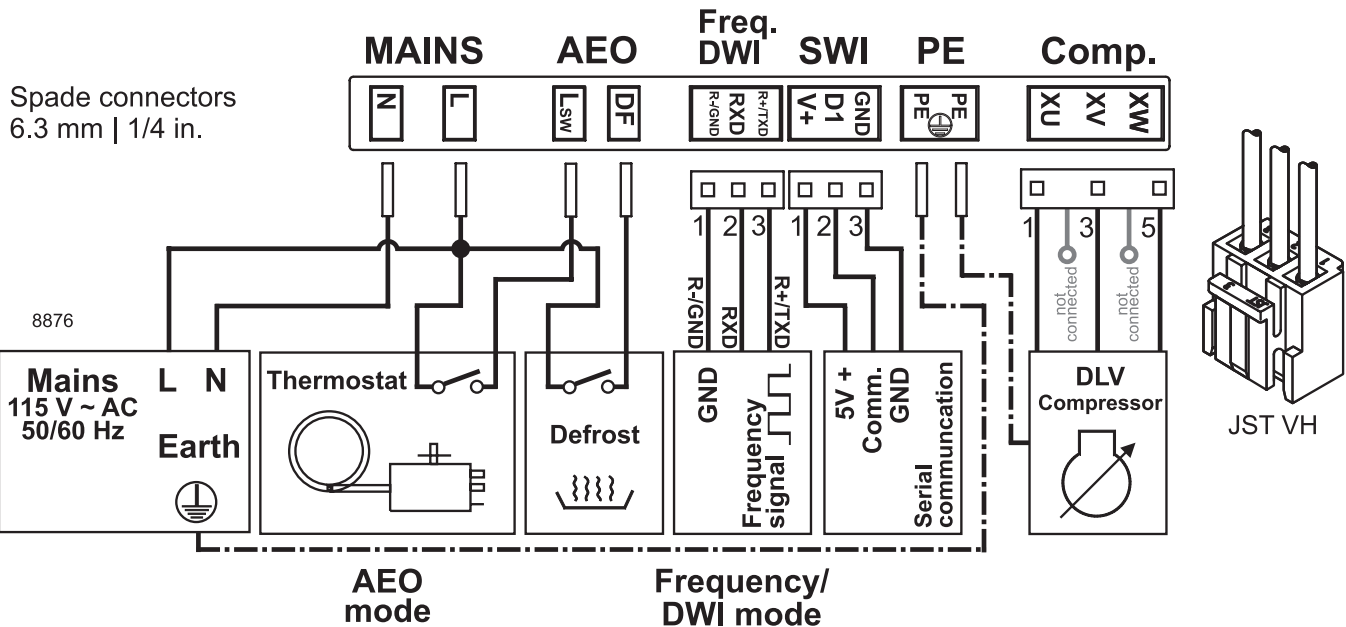
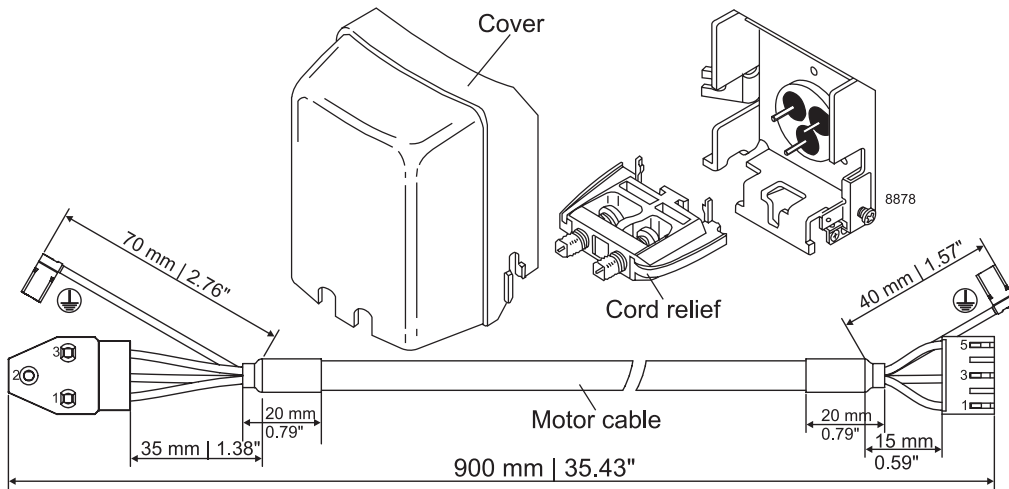
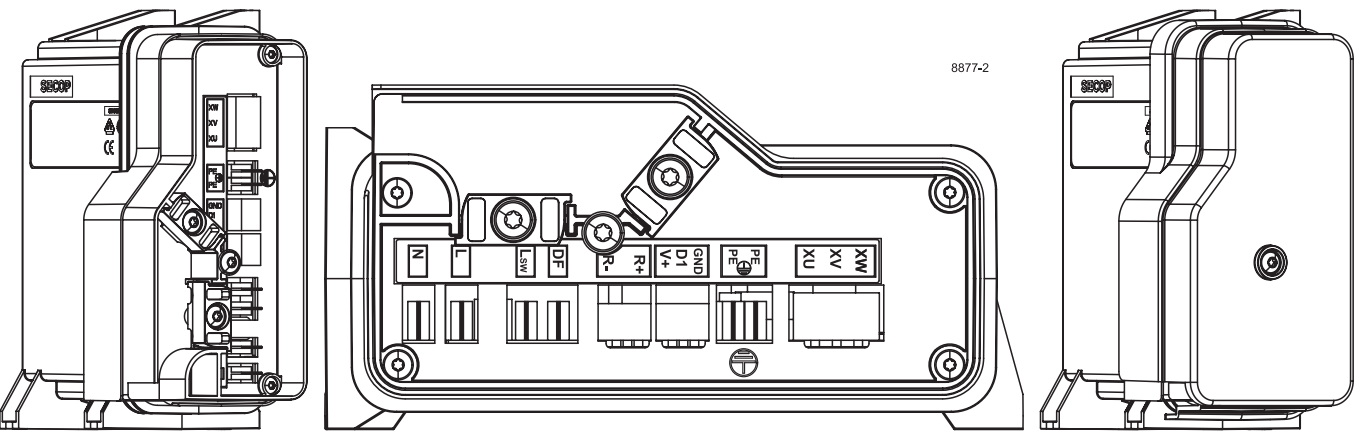

Secop accepts no responsibility for possible errors in catalogs, brochures, and other printed material. Secop reserves the right to alter its products without notice. This also applies to products already on order provided that such alterations can be made without subsequential changes being necessary to specifications already agreed. All trademarks in this material are the property of the respective companies. Secop and the Secop logotype are trademarks of Secop GmbH. All rights reserved. www.secop.com

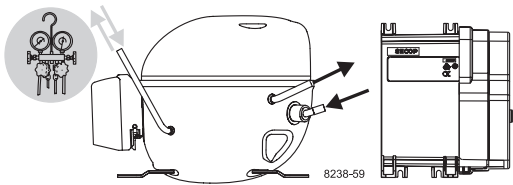

Instructions

DLV Compressors
100-127V 50/60Hz
105N446x
Series Controllers

SECCP

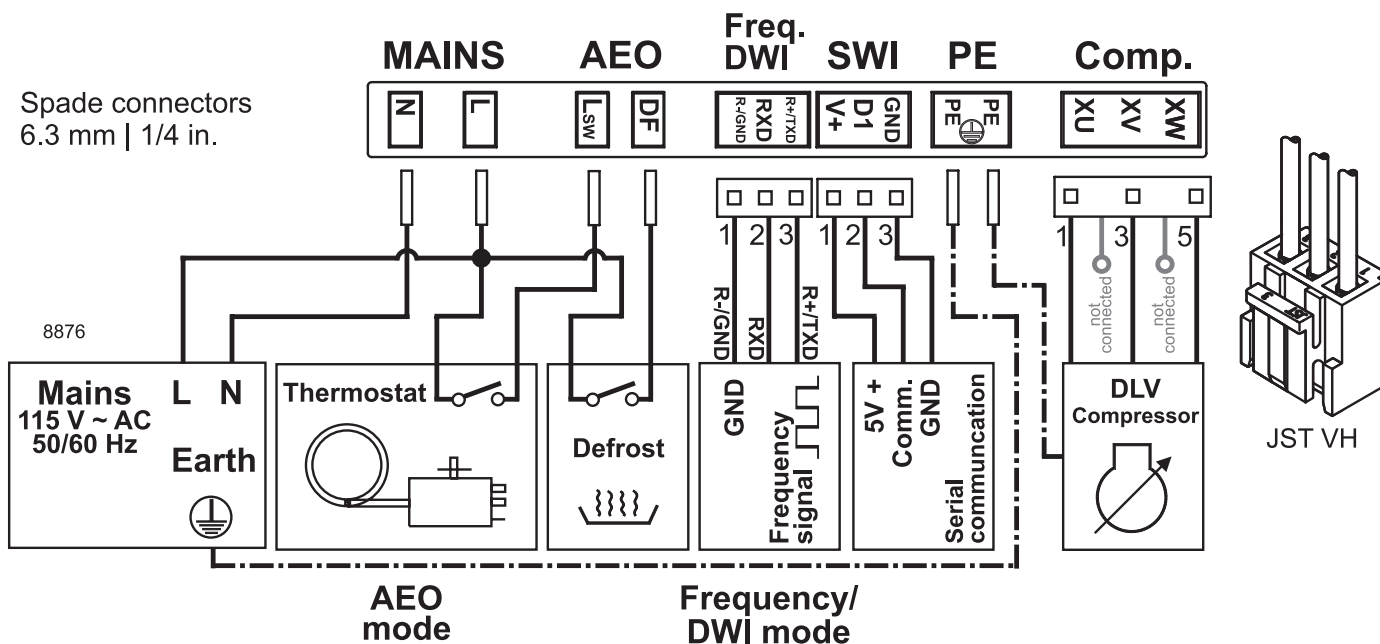
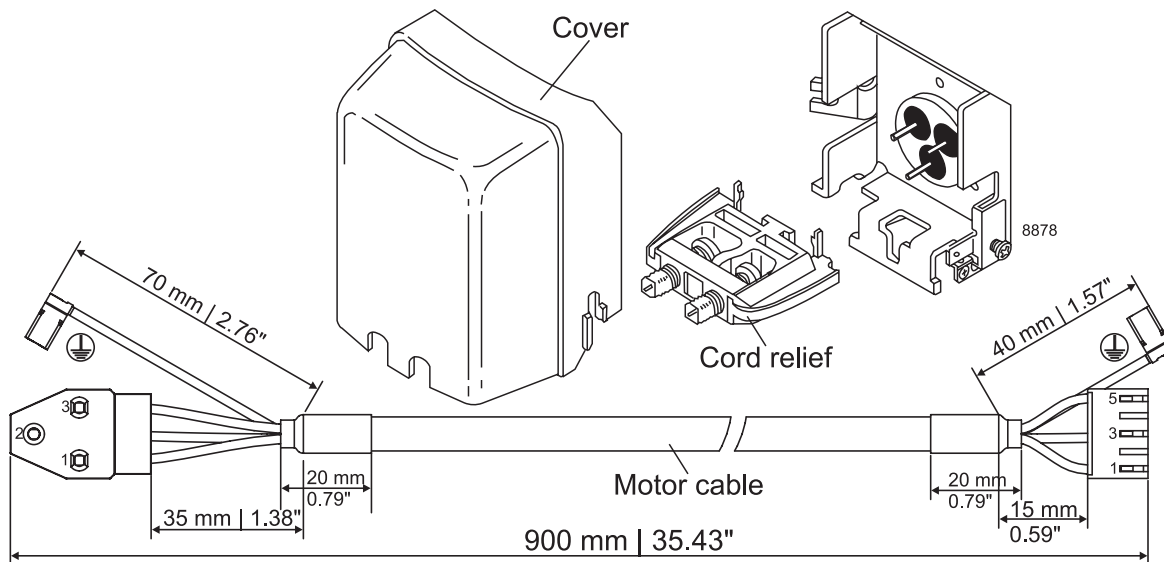
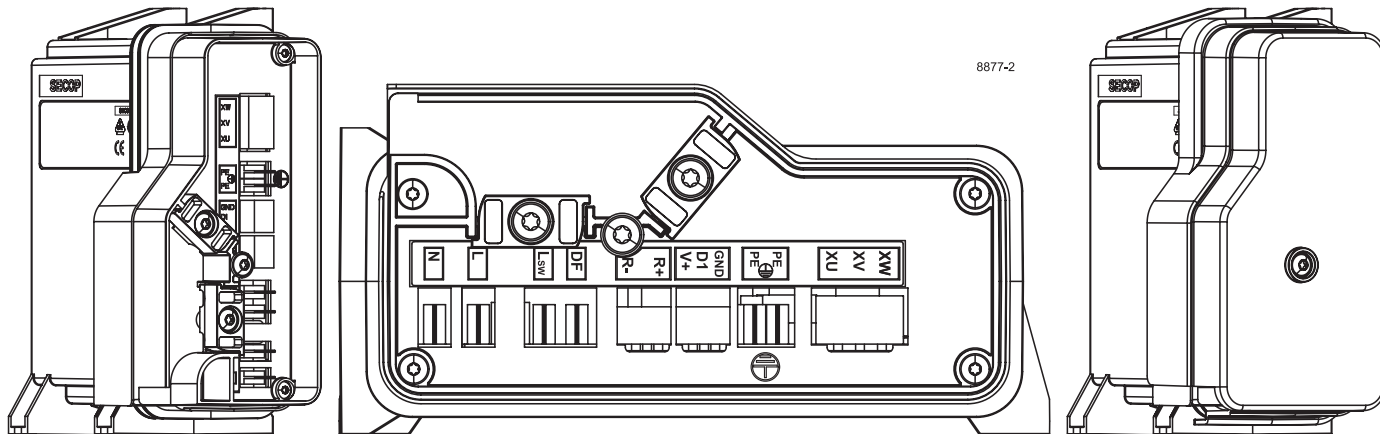

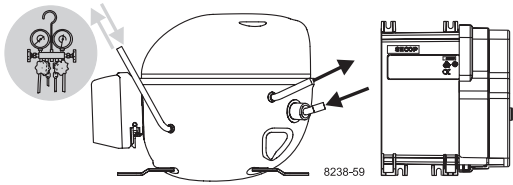

Instructions

DLV Compressors
100-127V 50/60Hz
105N446x
Series Controllers

SECCP



Service/Repair R290

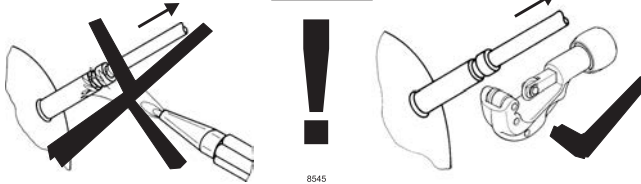

Brazing on Suction Connectors (Direct Intake)

representative image

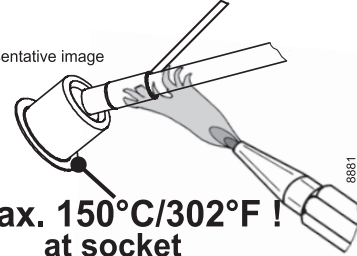

**! max. 150°C/302°F !
at socket**

brazing solder: phosphor (LP7) or silver

Refer to Product Bulletin: **Brazing on Suction Connectors
(Compressors with Direct Suction Intake)**

min. 3 m/s !

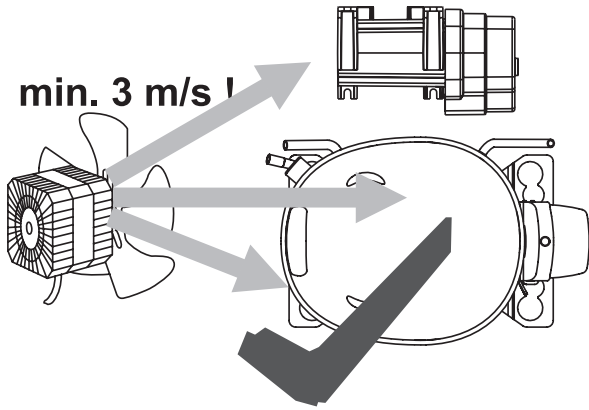

min. 3 m/s !

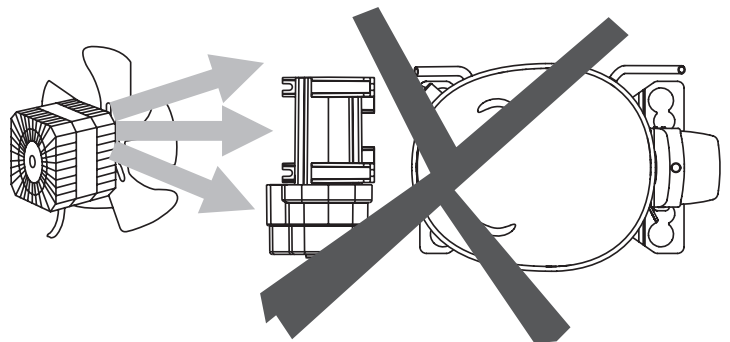
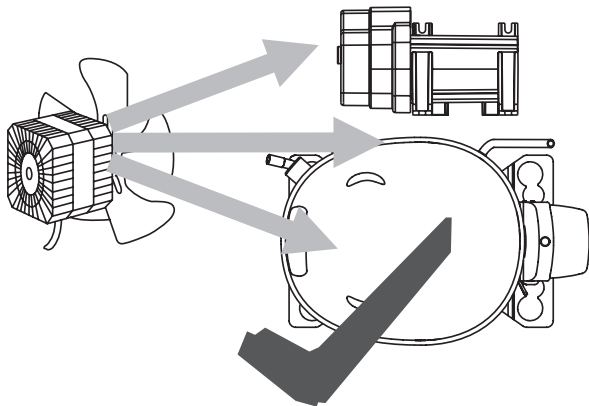
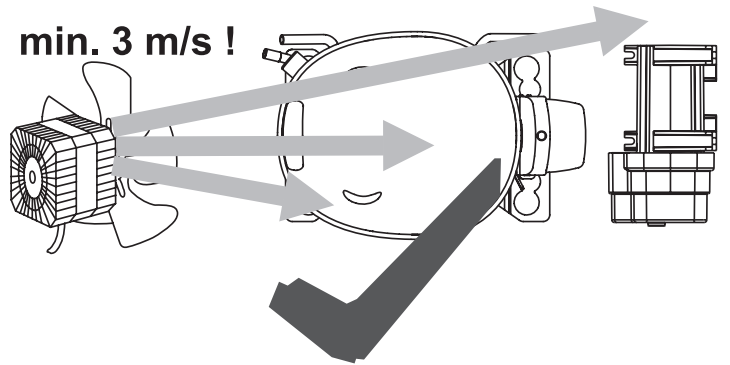

Airflow	3 m/s
Operating conditions 105N4460	+ 5 °C to 43 °C - humidity < 90 % rH non condensing
Storage conditions	-25 °C to 70 °C - humidity < 90 % rH non condensing
Supply voltage	100-127 V (± 10 %)
Frequency	50/60 Hz
Input power rating	450 W

Secop accepts no responsibility for possible errors in catalogs, brochures, and other printed material. Secop reserves the right to alter its products without notice. This also applies to products already on order provided that such alterations can be made without subsequent changes being necessary to specifications already agreed. All trademarks in this material are the property of the respective companies. Secop and the Secop logotype are trademarks of Secop GmbH. All rights reserved. www.secop.com