

## Single Pack SC18GH 220-240V 50Hz CSIR

Single pack code number: **195B4407**

Position	Title	Code	Amount
1	Compressor SC18GH	104G8860	1
2	Starting relay	117U6019	1
3	Starting capacitor (80 $\mu$ F 220V, 6.3mm)	117U5017	1
4	Cord relief	103N1004	1
5	Cover	103N2009	1
6	Bolt joint for one compressor   M6   $\varnothing$ 16mm	118-1917	1

Secop GmbH • Lise-Meitner-Straße 29 • 24941 Flensburg, Germany • Tel: +49 461 4941 0 • [www.secop.com](http://www.secop.com)

Secop accepts no responsibility for possible errors in catalogs, brochures, and other printed material. Secop reserves the right to alter its products without notice. This also applies to products already on order provided that such alterations can be made without subsequent changes being necessary to specifications already agreed. All trademarks in this material are the property of the respective companies. Secop and the Secop logotype are trademarks of Secop GmbH. All rights reserved.

## Model

Designation	<b>SC18GH</b>	220-240V/50Hz 1~	Sales code:	<b>104G8860</b>
-------------	---------------	------------------	-------------	-----------------

## Compressor design

Oil type	Polyolester	Refrigerant(s)	<b>R134a</b>
Oil viscosity	22cST	Displacement	17,69cm <sup>3</sup> / 1,08cu.in
Oil quantity	500cm <sup>3</sup> / 16,9fl.oz	Compressors on pallet	80
Refr. charge - tech. limit	1300g / 45,9oz		
Free gas volume comp.	1460cm <sup>3</sup> / 49,4fl.oz		
Weight	13,5kg / 29,8lbs		
Motor protection	1# internal		
Winding resistance main	3,7Ω (at 25°C)		
Winding resistance aux	14Ω (at 25°C)		
Max. winding temp.	125°C / 257°F		
Max. discharge temp.	135°C / 275°F		



## General - Configurations with SC18GH

	<b>Conf. 1</b>
Motorconfiguration	CSIR
Power supply (nominal)	220-240V/50Hz
Number of phases	1
Voltage range	198-254V
Approvals	VDE
Starting torque	HST
Note	- / -

## Applications with SC18GH

	<b>Conf. 1</b>
Refrigerant	R134a
Application	HBP
System cooling	fan 3m/s
Hot gas defrost	OK
Long interval pull down	OK

## Electrical data - Configurations with SC18GH

	<b>Conf. 1</b>
Starting device type	relay
Run capacitor	-/-
Start capacitor	80μF
LRA (locked rotor amps / 4s)	
RLA (rated load amps / 1s)	-/-A
Cut in current	

## Model

Designation

**SC18GH**

220-240V/50Hz 1~

Sales code:

**104G8860**

## Compressor dimensions

Housing	A Height	219mm / 8,62in
	B Height	213mm / 8,39in
	C Length shell	218mm / 8,58in
	D Length w. cover	255mm / 10,04in
	E Width	151mm / 5,94in

Connectors	Suction X	Discharge Y	Process Z
Diameter [mm]	øi 10,11-10,29	øi 8,11-8,29	øi 6,11-6,29
(i:inside, o:outside) [in]	øi 0,4-0,41	øi 0,32-0,33	øi 0,24-0,25
Material	copper	copper	copper
Horizontal angle ±2°	37°	37°	143°
Vertical angle ±2°	30°	0°	150°
Position l/h/w [mm]	107/193/55	115/110/63	-107/193/55
[in]	4,2/7,6/2,2	4,5/4,3/2,5	-4,2/7,6/2,2
Straight tube l. [mm]	12	12	12
[in]	0,5	0,5	0,5



## Compressor fixation



## Bolt joint



## Snap-on



## Mounting accessories

Mounting accessories	one comp.	multi pack
Bolt joint   M6   ø16mm	118-1917	118-1918
Bolt joint   ø1/4"   ø16mm	118-1946	
Bolt joint   ø1/4"   ø19mm	118-1949	
Snap-on   ø7,3   ø16mm	118-1947	118-1919

## Application notes

Provision for PE Grounding is located at the PE Stamp on the compressor

## Model

Designation	<b>SC18GH</b>	<b>220-240V/50Hz</b>	<b>Conf. 1</b>	Sales code:	<b>104G8860</b>
-------------	---------------	----------------------	----------------	-------------	-----------------

## Configuration

Motorconfiguration	CSIR
Power supply (nominal)	220-240V/50Hz 1~
Refrigerant	R134a
Application	HBP
Voltage range	198-254V
Starting torque	HST
Approvals	VDE

## Electrical accessories / wiring diagram

CSIR

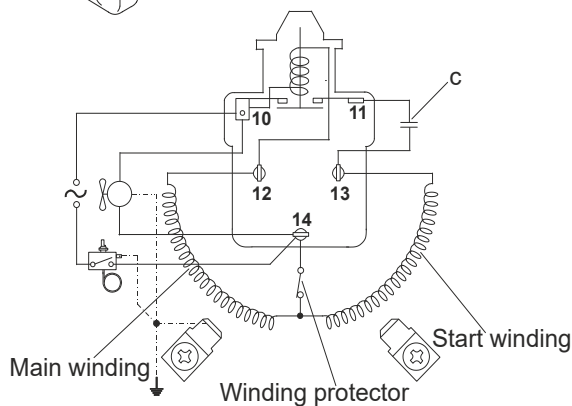
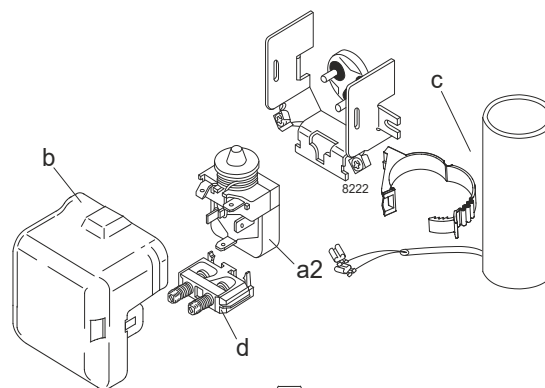

## Ambient/ machine room temperatures minimum /maximum

Ambient temperature range: 10 - 43°C / 50 - 110°F

Machine room temperature range: 10 - 48°C / 50 - 119°F

Compressor cooling: fan 3m/s

## Operation Limits

## Operation pressure range

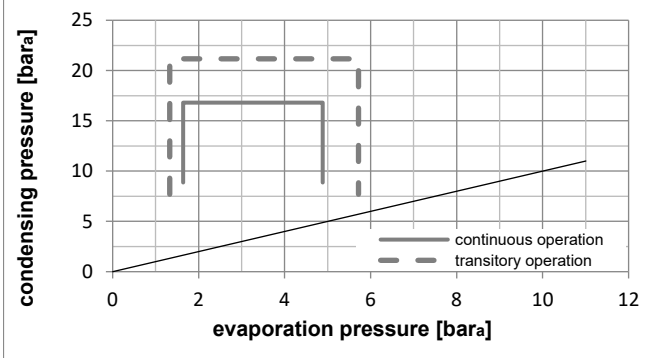
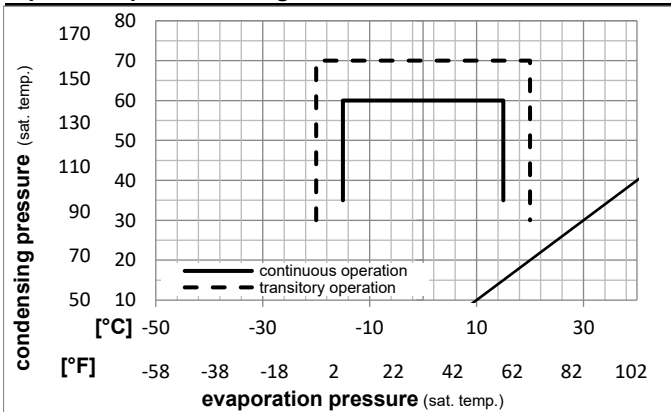

## Components

a2	relay	117U6019
c	start capacitor (80μF)	117U5017
d	cord relief	103N1004
b	plastic cover	103N2009

### Model

Designation **SC18GH** **220-240V/50Hz** Conf. 1 Sales code: **104G8860**

### Optimization + standard conditions

R134a, 220V/50Hz, CSIR, fan 3m/s, VDE

Evaporating pressure (saturation temperature)					Condensing pressure (saturation temperature)						Power consumption				
					Return gas temp.			Liquid temp.			Current consumption			Ref. mass flow	
					Cooling capacity			COP	EER	P1			I	m	
					[W]	[Btu/h]	[kcal/h]	[W/W]	[Btu/Wh]	[kcal/Wh]	[W]	[A]	[kg/h]		
pe	pc	RGT	Tliq												
[°C]	[°C]	[°C]	[°C]											ASHRAE HBP	
[°F]	[°F]	[°F]	[°F]												
7,2	54	35	46		1632,7	5576	1405,1	2,27	7,75	1,95	719,6	3,95	36,22	ASHRAE HBP	
45	130	95	115												
5	55	32	55		1340,1	4577	1153,3	1,92	6,57	1,66	696,8	3,85	33,02	cecomaf HBP	
41	131	90	131												
5	50	20	50		1396,6	4770	1201,9	2,12	7,22	1,82	660,3	3,72	35,19	EN12900 HBP	
41	122	68	122												
-7	54	35	46		876,5	2993	754,3	1,62	5,52	1,39	542,3	3,27	19,12	ASHRAE MBP	
20	130	95	115												
-10	55	32	55		675,6	2307	581,4	1,36	4,63	1,17	497,9	3,13	16,34	cecomaf MBP	
14	131	90	131												
-10	45	20	45		771,9	2636	664,3	1,64	5,61	1,41	469,8	3,04	18,07	EN12900 MBP	
14	113	68	113												

### Performance tables

R134a, 220V/50Hz, CSIR, fan 3m/s, VDE

	pe		Cooling capacity			COP	EER	P1	I	m	
	[°C]	[°F]	[W]	[Btu/h]	[kcal/h]	[W/W]	[Btu/Wh]	[kcal/Wh]	[W]	[A]	[kg/h]
[°C / °F]	-15	5	624,1	2131	537,1	1,52	5,18	1,31	411,1	2,87	13,60
cond. pressure	-10	14	800,8	2735	689,2	1,70	5,82	1,47	469,8	3,04	17,53
pc= 45/113	-5	23	1019,9	3483	877,7	1,94	6,64	1,67	524,9	3,22	22,43
return gas temp.	0	32	1280,8	4374	1102,2	2,22	7,58	1,91	577,1	3,40	28,32
RGT= 32/90	5	41	1583,0	5406	1362,3	2,53	8,63	2,17	626,7	3,60	35,24
liquid temp	10	50	1925,9	6577	1657,5	2,86	9,75	2,46	674,3	3,80	43,22
Tliq= 45/113	15	59	2309,1	7886	1987,2	3,21	10,95	2,76	720,2	4,00	52,30
[°C / °F]	-15	5	539,0	1841	463,8	1,27	4,33	1,09	424,8	2,90	12,97
cond. pressure	-10	14	675,6	2307	581,4	1,36	4,63	1,17	497,9	3,13	16,34
pc= 55/131	-5	23	855,0	2920	735,8	1,51	5,15	1,30	567,3	3,36	20,78
return gas temp	0	32	1076,7	3677	926,6	1,70	5,80	1,46	633,5	3,60	26,34
RGT= 32/90	5	41	1340,1	4577	1153,3	1,92	6,57	1,66	696,8	3,85	33,02
liquid temp	10	50	1644,7	5617	1415,4	2,17	7,41	1,87	757,9	4,11	40,88
Tliq= 55/131	15	59	1989,9	6796	1712,6	2,44	8,32	2,10	817,0	4,38	49,98



# SC Compressors





# SC Compressors

## Service/Repair – R290

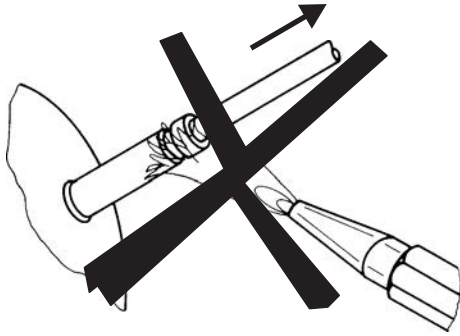

8545



Secop accepts no responsibility for possible errors in catalogs, brochures, and other printed material. Secop reserves the right to alter its products without notice. This also applies to products already on order provided that such alterations can be made without subsequent changes being necessary to specifications already agreed. All trademarks in this material are the property of the respective companies. Secop and the Secop logotype are trademarks of Secop GmbH. All rights reserved. [www.secop.com](http://www.secop.com)