

Single Pack KLF7.7CND 220-240V 50Hz CSIR

Single pack code number: **195B4597**

| Position | Title | Code | Amount |
|----------|---|----------|--------|
| 1 | Compressor KLF7.7CND | 106H2800 | 1 |
| 2 | KL accessories | 103N1060 | 1 |
| 3 | Starting capacitor (80 μ F 220V, 6.3mm) | 117U5001 | 1 |
| 4 | Starting relay (QLZ-5.5A, overload protector T0377/L6) | 117U7071 | 1 |
| 5 | Bolt joint for one compressor M6 \varnothing 16mm | 118-1917 | 1 |

Secop GmbH • Lise-Meitner-Straße 29 • 24941 Flensburg, Germany • Tel: +49 461 4941 0 • www.secop.com

Secop accepts no responsibility for possible errors in catalogs, brochures, and other printed material. Secop reserves the right to alter its products without notice. This also applies to products already on order provided that such alterations can be made without subsequent changes being necessary to specifications already agreed. All trademarks in this material are the property of the respective companies. Secop and the Secop logotype are trademarks of Secop GmbH. All rights reserved.

Model

| | | | | |
|-------------|------------------|------------------|-------------|-----------------|
| Designation | KLF7.7CND | 220-240V/50Hz 1~ | Sales code: | 106H2800 |
|-------------|------------------|------------------|-------------|-----------------|

Compressor design

| | | | |
|----------------------------|---------------------------------|-----------------------|--------------------------------|
| Oil type | Polyolester | Refrigerant(s) | R290 |
| Oil viscosity | 10,4cSt | Displacement | 7,7cm ³ / 0,47cu.in |
| Oil quantity | 174cm ³ / 5,9fl.oz | Compressors on pallet | 100 |
| Refr. charge - tech. limit | 200g / 7,1oz | | |
| Free gas volume comp. | 1575cm ³ / 53,3fl.oz | | |
| Weight | 9,6kg / 21,2lbs | | |
| Motor protection | external | | |
| Winding resistance main | 8,4Ω (at 25°C) | | |
| Winding resistance aux | 11,9Ω (at 25°C) | | |
| Max. winding temp. | 125°C / 257°F | | |
| Max. discharge temp. | 130°C / 266°F | | |



General - Configurations with KLF7.7CND

| | Conf. 1 | Conf. 2 |
|------------------------|----------------|----------------|
| Motorconfiguration | CSIR | RSCR |
| Power supply (nominal) | 220-240V/50Hz | 220-240V/50Hz |
| Number of phases | 1 | 1 |
| Voltage range | 198-254V | 198-254V |
| Approvals | VDE, CCC | VDE, CCC |
| Starting torque | HST | LST |
| Note | - / - | |

Applications with KLF7.7CND

| | Conf. 1 | Conf. 2 |
|-------------------------|----------------|----------------|
| Refrigerant | R290 | R290 |
| Application | LBP+MBP | LBP+MBP |
| System cooling | fan 3m/s | fan 3m/s |
| Hot gas defrost | OK | OK |
| Long interval pull down | OK | OK |

Electrical data - Configurations with KLF7.7CND

| | Conf. 1 | Conf. 2 |
|------------------------------------|----------------|----------------|
| Starting device type | relay | PTC |
| Run capacitor | - / - | 5μF |
| Start capacitor | 80μF | - / - |
| LRA (locked rotor amps / 4s/ U(N)) | 13,2A | 13,2A |
| RLA (rated load amps / 1s/ U(N)) | 2,1A | 2,1A |
| Cut in current (U(N)) | 12,3A | 18,1A |

Model

Designation

KLF7.7CND

220-240V/50Hz 1~

Sales code:

106H2800

Compressor dimensions

| Housing | A Height | 182mm / 7,17in |
|---------|-------------------|----------------|
| | B Height | 175mm / 6,89in |
| | C Length shell | 198mm / 7,8in |
| | D Length w. cover | 238mm / 9,37in |
| | E Width | 160mm / 6,3in |

| Connectors | | Suction | Discharge | Process |
|-----------------------|------|--------------|--------------|--------------|
| | | X | Y | Z |
| Diameter | [mm] | øi 8,11-8,29 | øi 6,11-6,29 | øi 6,11-6,29 |
| (i:inside, o:outside) | [in] | øi 0,32-0,33 | øi 0,24-0,25 | øi 0,24-0,25 |
| Material | | copper | copper | copper |
| Horizontal angle | ±2° | 35° | 13° | 0° |
| Vertical angle | ±2° | 30° | 40° | 145° |
| Position l/h/w | [mm] | 119/73/59 | 117/107/66 | -88/101/71 |
| | [in] | 4,7/2,9/2,3 | 4,6/4,2/2,6 | -3,5/4/2,8 |
| Straight tube l. | [mm] | 14 | 14 | 14 |
| | [in] | 0,5 | 0,5 | 0,5 |

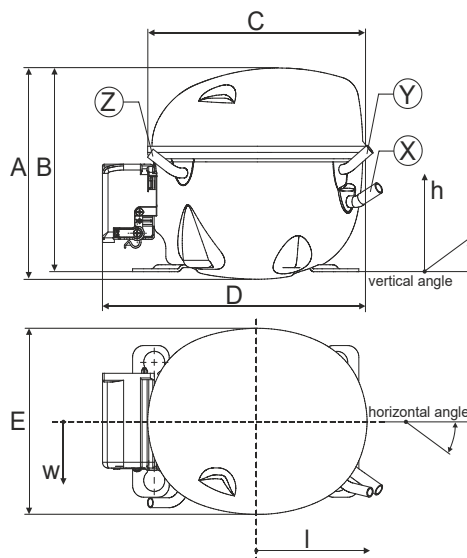

Compressor fixation

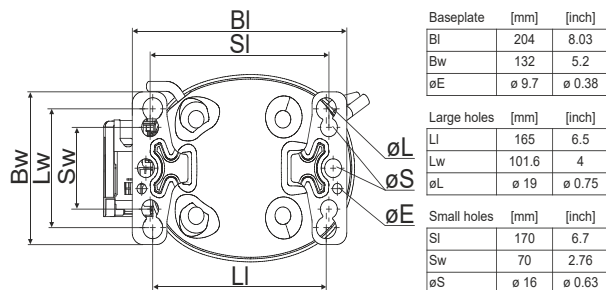

Bolt joint



Snap-on

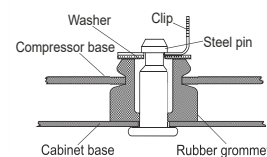

| Mounting accessories | one comp. | multi pack |
|----------------------------|-----------|------------|
| Bolt joint M6 ø16mm | 118-1917 | 118-1918 |
| Bolt joint ø1/4" ø16mm | 118-1946 | |
| Bolt joint ø1/4" ø19mm | 118-1949 | |
| Snap-on ø7,3 ø16mm | 118-1947 | 118-1919 |

Application notes

Provision for PE Grounding is located at the PE Stamp on the compressor

Model

| | | | | | |
|-------------|------------------|----------------------|----------------|-------------|-----------------|
| Designation | KLF7.7CND | 220-240V/50Hz | Conf. 1 | Sales code: | 106H2800 |
|-------------|------------------|----------------------|----------------|-------------|-----------------|

Configuration

| | |
|------------------------|------------------|
| Motorconfiguration | CSIR |
| Power supply (nominal) | 220-240V/50Hz 1~ |
| Refrigerant | R290 |
| Application | LBP+MBP |
| Voltage range | 198-254V |
| Starting torque | HST |
| Approvals | VDE CCC |

Electrical accessories / wiring diagram

CSIR



Ambient/ machine room temperatures minimum /maximum

| | |
|---------------------------------|------------------------|
| Ambient temperature range: | 10 - 43°C / 50 - 110°F |
| Machine room temperature range: | 10 - 48°C / 50 - 119°F |
| Compressor cooling: | fan 3m/s |

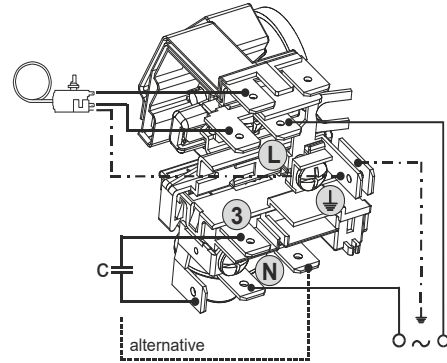

Operation pressure range

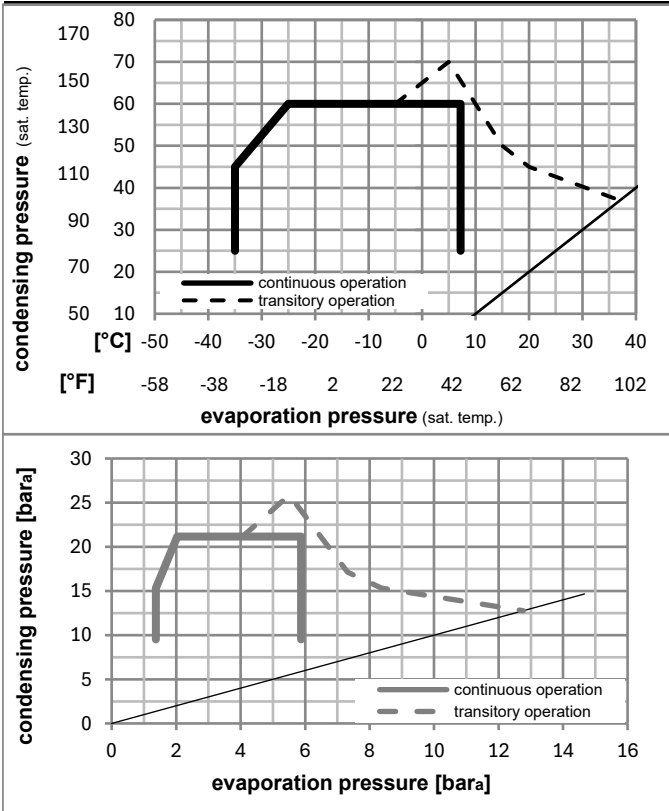

Components

| | | |
|------|------------------------------------|----------|
| a5 | current relay (T0377/L6-S1) | 117U7071 |
| c | start capacitor (80µF, 6.3mm) | 117U5001 |
| b, d | cover + clamp + screws(5VA) in bag | 103N1060 |

Alternative components

| | | |
|------|------------------------------------|----------|
| b, d | 100x cover + clamp + screws(5VA) | 103N2060 |
| b, d | cover + clamp + screws(5VA-compl.) | 103N0600 |

Model

Designation **KLF7.7CND** **220-240V/50Hz** Conf. 1 Sales code: **106H2800**

Optimization + standard conditions

R290, 220V/50Hz, CSIR, fan 3m/s, VDE, CCC

| | Evaporating pressure (saturation temperature) | | | | Cooling capacity | | | COP | EER | Power consumption | | | ASHRAE LBP | |
|--|---|------|------|------|------------------|---------|----------|-------|----------|-------------------|-------|------|------------|-------------|
| | pe | pc | RGT | Tliq | [W] | [Btu/h] | [kcal/h] | | | P1 | I | m | | |
| | [°C] | [°F] | [°C] | [°F] | [W] | [Btu/h] | [kcal/h] | [W/W] | [Btu/Wh] | [kcal/Wh] | [W] | [A] | [kg/h] | |
| | -23 | 54 | 32 | 32 | 384,5 | 1313 | 330,9 | 1,52 | 5,18 | 1,30 | 253,7 | 1,68 | 3,89 | ASHRAE LBP |
| | -10 | 130 | 90 | 90 | | | | | | | | | | |
| | -25 | 55 | 32 | 55 | 287,6 | 982 | 247,5 | 1,18 | 4,02 | 1,01 | 244,6 | 1,65 | 3,58 | cecomaf LBP |
| | -13 | 131 | 90 | 131 | | | | | | | | | | |
| | -35 | 40 | 20 | 40 | 222,6 | 760 | 191,6 | 1,20 | 4,12 | 1,04 | 184,8 | 1,49 | 2,54 | EN12900 LBP |
| | -31 | 104 | 68 | 104 | | | | | | | | | | |
| | -7 | 54 | 35 | 46 | 687,7 | 2349 | 591,9 | 2,00 | 6,84 | 1,72 | 343,3 | 1,99 | 7,85 | ASHRAE MBP |
| | 20 | 130 | 95 | 115 | | | | | | | | | | |
| | -10 | 55 | 32 | 55 | 547,3 | 1869 | 471,0 | 1,67 | 5,71 | 1,44 | 327,5 | 1,93 | 6,92 | cecomaf MBP |
| | 14 | 131 | 90 | 131 | | | | | | | | | | |
| | -10 | 45 | 20 | 45 | 608,6 | 2079 | 523,8 | 2,03 | 6,93 | 1,75 | 299,9 | 1,83 | 7,47 | EN12900 MBP |
| | 14 | 113 | 68 | 113 | | | | | | | | | | |

Performance tables

R290, 220V/50Hz, CSIR, fan 3m/s, VDE, CCC

| | pe | | Cooling capacity | | | COP | EER | P1 | I | m | |
|------------------|------|------|------------------|---------|----------|------|-------|------|-------|------|-------|
| | [°C] | [°F] | [W] | [Btu/h] | [kcal/h] | | | | | | |
| [°C / °F] | -35 | -31 | 210,1 | 717 | 180,8 | 1,11 | 3,79 | 0,96 | 189,1 | 1,50 | 2,35 |
| cond. pressure | -25 | -13 | 342,0 | 1168 | 294,3 | 1,46 | 4,98 | 1,26 | 234,3 | 1,62 | 3,86 |
| pc= 45/113 | -15 | 5 | 523,0 | 1786 | 450,1 | 1,88 | 6,42 | 1,62 | 278,4 | 1,76 | 5,95 |
| return gas temp. | -10 | 14 | 633,6 | 2164 | 545,3 | 2,11 | 7,22 | 1,82 | 299,9 | 1,83 | 7,25 |
| RGT= 32/90 | -5 | 23 | 758,6 | 2591 | 652,8 | 2,36 | 8,07 | 2,03 | 321,1 | 1,91 | 8,73 |
| liquid temp | 0 | 32 | 898,6 | 3069 | 773,3 | 2,63 | 8,97 | 2,26 | 342,0 | 1,99 | 10,42 |
| Tliq= 45/113 | 7,2 | 45 | 1127,9 | 3852 | 970,7 | 3,04 | 10,37 | 2,61 | 371,3 | 2,10 | 13,25 |
| [°C / °F] | -35 | -31 | 170,7 | 583 | 146,9 | 0,92 | 3,13 | 0,79 | 186,0 | 1,49 | 2,11 |
| cond. pressure | -25 | -13 | 287,6 | 982 | 247,5 | 1,18 | 4,02 | 1,01 | 244,6 | 1,65 | 3,58 |
| pc= 55/131 | -15 | 5 | 448,6 | 1532 | 386,0 | 1,49 | 5,10 | 1,28 | 300,5 | 1,84 | 5,64 |
| return gas temp | -10 | 14 | 547,3 | 1869 | 471,0 | 1,67 | 5,71 | 1,44 | 327,5 | 1,93 | 6,92 |
| RGT= 32/90 | -5 | 23 | 659,1 | 2251 | 567,2 | 1,86 | 6,36 | 1,60 | 353,6 | 2,03 | 8,40 |
| liquid temp | 0 | 32 | 784,6 | 2680 | 675,3 | 2,07 | 7,07 | 1,78 | 379,1 | 2,13 | 10,08 |
| Tliq= 55/131 | 7,2 | 45 | 991,0 | 3385 | 852,9 | 2,39 | 8,17 | 2,06 | 414,5 | 2,27 | 12,91 |

Model

| | | | | | |
|-------------|------------------|----------------------|----------------|-------------|-----------------|
| Designation | KLF7.7CND | 220-240V/50Hz | Conf. 2 | Sales code: | 106H2800 |
|-------------|------------------|----------------------|----------------|-------------|-----------------|

Configuration

| | |
|------------------------|------------------|
| Motorconfiguration | RSCR |
| Power supply (nominal) | 220-240V/50Hz 1~ |
| Refrigerant | R290 |
| Application | LBP+MBP |
| Voltage range | 198-254V |
| Starting torque | LST |
| Approvals | VDE CCC |

Electrical accessories / wiring diagram

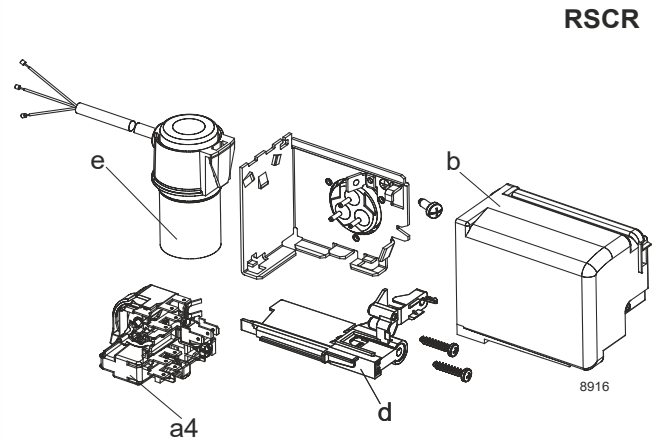

Ambient/ machine room temperatures minimum /maximum

| | |
|---------------------------------|------------------------|
| Ambient temperature range: | 10 - 43°C / 50 - 110°F |
| Machine room temperature range: | 10 - 48°C / 50 - 119°F |
| Compressor cooling: | fan 3m/s |

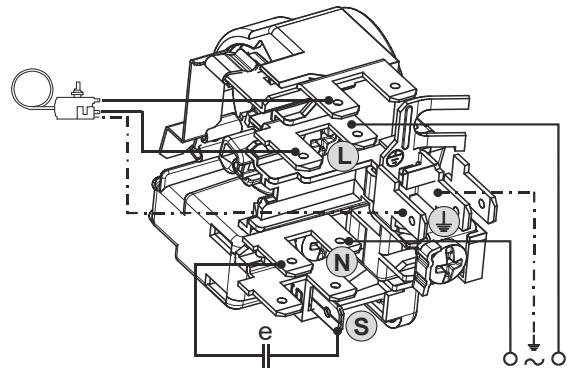

Operation pressure range

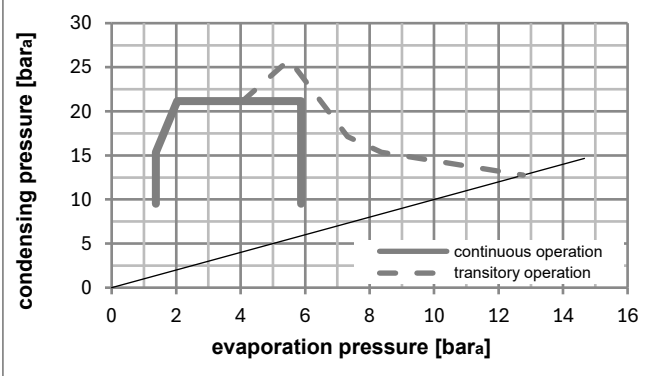
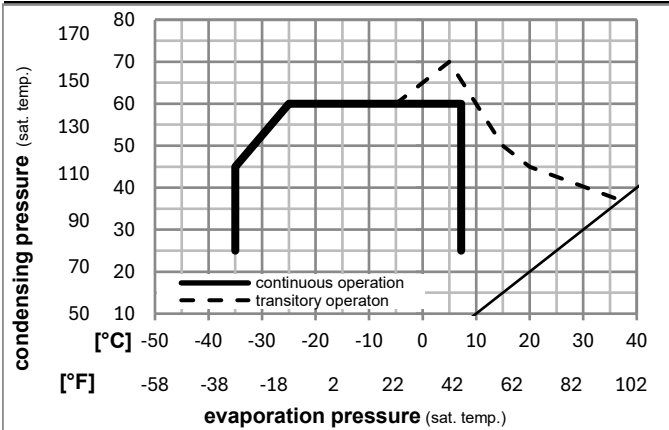

Components

| | | |
|------|------------------------------------|----------|
| a4 | DAS1 (PTC,6.3mm, T0377/L6 - S1) | 103N0250 |
| e | run capacitor (5µF, 6.3mm) | 117-7191 |
| b, d | cover + clamp + screws(5VA) in bag | 103N1060 |

Alternative components

| | | |
|----|---------------------------------|----------|
| a4 | ZAS1 (PTC,4.8mm, T0377/L6 - S1) | 103N0252 |
| e | run capacitor (5µF, 4.8mm) | 117-7190 |

| | | |
|------|------------------------------------|----------|
| b, d | 100x cover + clamp + screws(5VA) | 103N2060 |
| b, d | cover + clamp + screws(5VA-compl.) | 103N0600 |

Model

Designation **KLF7.7CND** **220-240V/50Hz** Conf. 2 Sales code: **106H2800**

Optimization + standard conditions

R290, 220V/50Hz, RSCR, fan 3m/s, VDE, CCC

| | Evaporating pressure (saturation temperature) | | | | Cooling capacity | | | COP | EER | | | Power consumption | | | ASHRAE LBP |
|------|---|-----|-----|------|------------------|---------|----------|------|-------|----------|-----------|-------------------|------|-------------|------------|
| | pe | pc | RGT | Tliq | [W] | [Btu/h] | [kcal/h] | | [W/W] | [Btu/Wh] | [kcal/Wh] | P1 | I | m | |
| [°C] | -23 | 54 | 32 | 32 | 387,4 | 1323 | 333,4 | 1,60 | 5,46 | 1,38 | 242,2 | 1,36 | 3,92 | | |
| [°F] | -10 | 130 | 90 | 90 | | | | | | | | | | | |
| | | | | | | | | | | | | | | | |
| [°C] | -25 | 55 | 32 | 55 | 289,8 | 990 | 249,4 | 1,24 | 4,24 | 1,07 | 233,6 | 1,33 | 3,61 | cecomaf LBP | |
| [°F] | -13 | 131 | 90 | 131 | | | | | | | | | | | |
| | | | | | | | | | | | | | | | |
| [°C] | -35 | 40 | 20 | 40 | 224,1 | 765 | 192,9 | 1,27 | 4,32 | 1,09 | 177,0 | 1,13 | 2,56 | EN12900 LBP | |
| [°F] | -31 | 104 | 68 | 104 | | | | | | | | | | | |
| | | | | | | | | | | | | | | | |
| [°C] | -7 | 54 | 35 | 46 | 693,9 | 2370 | 597,2 | 2,12 | 7,26 | 1,83 | 326,6 | 1,69 | 7,92 | ASHRAE MBP | |
| [°F] | 20 | 130 | 95 | 115 | | | | | | | | | | | |
| | | | | | | | | | | | | | | | |
| [°C] | -10 | 55 | 32 | 55 | 552,0 | 1885 | 475,1 | 1,77 | 6,05 | 1,52 | 311,7 | 1,63 | 6,98 | cecomaf MBP | |
| [°F] | 14 | 131 | 90 | 131 | | | | | | | | | | | |
| | | | | | | | | | | | | | | | |
| [°C] | -10 | 45 | 20 | 45 | 613,6 | 2096 | 528,1 | 2,15 | 7,33 | 1,85 | 285,9 | 1,53 | 7,53 | EN12900 MBP | |
| [°F] | 14 | 113 | 68 | 113 | | | | | | | | | | | |
| | | | | | | | | | | | | | | | |

Performance tables

R290, 220V/50Hz, RSCR, fan 3m/s, VDE, CCC

| | pe | | Cooling capacity | | | COP | EER | | P1 | I | m |
|------------------|------|------|------------------|---------|----------|------|-------|----------|-------|------|-------|
| | [°C] | [°F] | [W] | [Btu/h] | [kcal/h] | | [W/W] | [Btu/Wh] | | | |
| [°C / °F] | -35 | -31 | 211,5 | 722 | 182,0 | 1,17 | 3,99 | 1,00 | 181,2 | 1,14 | 2,37 |
| cond. pressure | -25 | -13 | 344,5 | 1177 | 296,5 | 1,54 | 5,25 | 1,32 | 223,9 | 1,29 | 3,89 |
| pc= 45/113 | -15 | 5 | 527,1 | 1800 | 453,7 | 1,98 | 6,78 | 1,71 | 265,6 | 1,44 | 6,00 |
| return gas temp. | -10 | 14 | 638,8 | 2182 | 549,8 | 2,23 | 7,63 | 1,92 | 285,9 | 1,53 | 7,31 |
| RGT= 32/90 | -5 | 23 | 765,1 | 2613 | 658,4 | 2,50 | 8,54 | 2,15 | 305,9 | 1,61 | 8,81 |
| liquid temp | 0 | 32 | 906,6 | 3096 | 780,2 | 2,79 | 9,51 | 2,40 | 325,4 | 1,69 | 10,52 |
| Tliq= 45/113 | 7,2 | 45 | 1138,6 | 3888 | 979,9 | 3,23 | 11,02 | 2,78 | 352,8 | 1,80 | 13,38 |
| [°C / °F] | -35 | -31 | 171,9 | 587 | 147,9 | 0,96 | 3,30 | 0,83 | 178,1 | 1,14 | 2,13 |
| cond. pressure | -25 | -13 | 289,8 | 990 | 249,4 | 1,24 | 4,24 | 1,07 | 233,6 | 1,33 | 3,61 |
| pc= 55/131 | -15 | 5 | 452,3 | 1545 | 389,2 | 1,58 | 5,39 | 1,36 | 286,4 | 1,53 | 5,69 |
| return gas temp | -10 | 14 | 552,0 | 1885 | 475,1 | 1,77 | 6,05 | 1,52 | 311,7 | 1,63 | 6,98 |
| RGT= 32/90 | -5 | 23 | 665,1 | 2271 | 572,4 | 1,98 | 6,75 | 1,70 | 336,3 | 1,73 | 8,47 |
| liquid temp | 0 | 32 | 792,2 | 2706 | 681,8 | 2,20 | 7,51 | 1,89 | 360,0 | 1,83 | 10,18 |
| Tliq= 55/131 | 7,2 | 45 | 1001,3 | 3419 | 861,7 | 2,55 | 8,71 | 2,19 | 392,8 | 1,97 | 13,04 |



KL Compressors



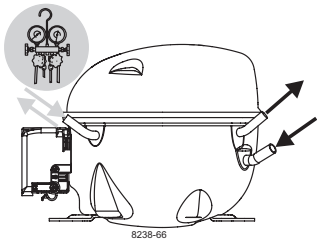

KL Compressors



Service/Repair – R290

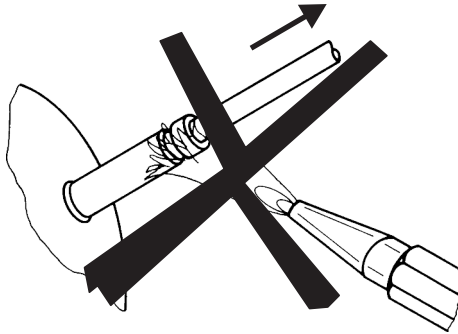

8545

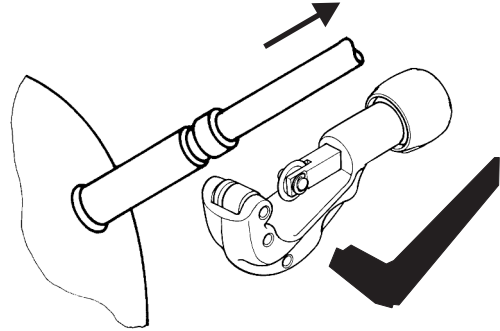

Secop accepts no responsibility for possible errors in catalogs, brochures, and other printed material. Secop reserves the right to alter its products without notice. This also applies to products already on order provided that such alterations can be made without subsequent changes being necessary to specifications already agreed. All trademarks in this material are the property of the respective companies. Secop and the Secop logotype are trademarks of Secop GmbH. All rights reserved. www.secop.com