

Single Pack KLF6.6MFT 200-240V 50Hz / 208-230V 60Hz CSIR

Single pack code number: **195B4688**

Position	Title	Code	Amount
1	Compressor KLF6.6MFT	106G2701	1
2	KL accessories	103N1060	1
3	Starting capacitor (80 μ F 220V, 6.3mm)	117U5001	1
4	Starting relay (QLZ-5.5A, overload protector T0377/L6)	117U7071	1
5	Bolt joint for one compressor M6 \varnothing 16mm	118-1917	1

Secop GmbH • Lise-Meitner-Straße 29 • 24941 Flensburg, Germany • Tel: +49 461 4941 0 • www.secop.com

Secop accepts no responsibility for possible errors in catalogs, brochures, and other printed material. Secop reserves the right to alter its products without notice. This also applies to products already on order provided that such alterations can be made without subsequent changes being necessary to specifications already agreed. All trademarks in this material are the property of the respective companies. Secop and the Secop logotype are trademarks of Secop GmbH. All rights reserved.

Model

Designation	KLF6.6MFT	200-240V/50Hz 1~	208-230V/60Hz 1~	Sales code:	106G2701
-------------	------------------	------------------	------------------	-------------	-----------------

Compressor design

Oil type	Polyolester	Refrigerant(s)	R134a
Oil viscosity	10,4cSt	Displacement	6,6cm ³ / 0,4cu.in
Oil quantity	174cm ³ / 5,9fl.oz	Compressors on pallet	100
Refr. charge - tech. limit	400g / 14,1oz		
Free gas volume comp.	1580cm ³ / 53,4fl.oz		
Weight	9,4kg / 20,7lbs		
Motor protection	external		
Winding resistance main	8,4Ω (at 25°C)		
Winding resistance aux	11,9Ω (at 25°C)		
Max. winding temp.	125°C / 257°F		
Max. discharge temp.	130°C / 266°F		



General - Configurations with KLF6.6MFT

	Conf. 1	Conf. 2	Conf. 3	Conf. 4
Motorconfiguration	CSIR	RSCR	CSIR	RSCR
Power supply (nominal)	200-240V/50Hz	200-240V/50Hz	208-230V/60Hz	208-230V/60Hz
Number of phases	1	1	1	1
Voltage range	170-254V	170-254V	198-253V	198-253V
Approvals	VDE, UL, CCC	VDE, UL, CCC	VDE, UL, CCC	VDE, UL, CCC
Starting torque	HST	LST	HST	LST
Note	Compressor can operate safely in LBP, no official third-party approval yet			

Applications with KLF6.6MFT

	Conf. 1	Conf. 2	Conf. 3	Conf. 4
Refrigerant	R134a	R134a	R134a	R134a
Application	MBP	MBP	MBP	MBP
System cooling	fan 3m/s	fan 3m/s	fan 3m/s	fan 3m/s
Hot gas defrost	OK	OK	OK	OK
Long interval pull down	OK	OK	OK	OK

Electrical data - Configurations with KLF6.6MFT

	Conf. 1	Conf. 2	Conf. 3	Conf. 4
Starting device type	relay	PTC	relay	PTC
Run capacitor	-/-	5μF	-/-	5μF
Start capacitor	80μF	-/-	80μF	-/-
LRA (locked rotor amps / 4s/ U(N))	13,5A	13,5A	13,5A	13,5A
RLA (rated load amps / 1s/ U(N))	2,1A	2,1A	2,1A	2,1A
Cut in current (U(N))	12,3A	18,1A	12,3A	18,1A

Model

Designation

KLF6.6MFT

200-240V/50Hz 1~ 208-230V/60Hz 1~

Sales code:

106G2701

Compressor dimensions

Housing	A Height	182mm / 7,17in
	B Height	175mm / 6,89in
	C Length shell	198mm / 7,8in
	D Length w. cover	238mm / 9,37in
	E Width	160mm / 6,3in

Connectors		Suction	Discharge	Process
		X	Y	Z
Diameter	[mm]	øi 8,11-8,29	øi 6,11-6,29	øi 6,11-6,29
(i:inside, o:outside)	[in]	øi 0,32-0,33	øi 0,24-0,25	øi 0,24-0,25
Material		copper	copper	copper
Horizontal angle	±2°	35°	13°	0°
Vertical angle	±2°	30°	40°	145°
Position l/h/w	[mm]	119/73/59	117/107/66	-88/101/71
	[in]	4,7/2,9/2,3	4,6/4,2/2,6	-3,5/4/2,8
Straight tube l.	[mm]	14	14	14
	[in]	0,5	0,5	0,5

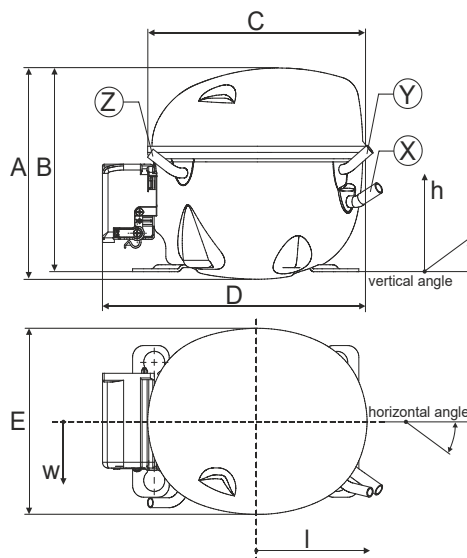

Compressor fixation

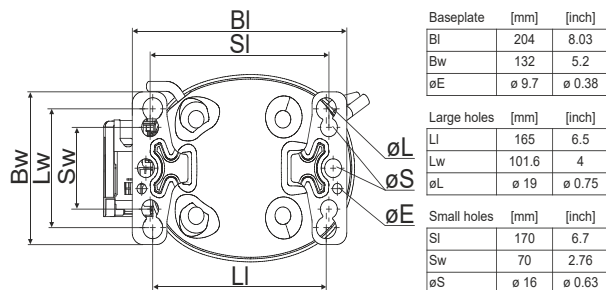

Bolt joint

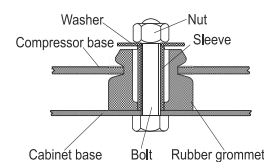

Snap-on

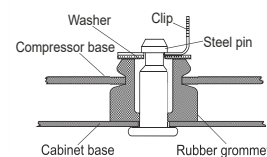

Mounting accessories

Mounting accessories	one comp.	multi pack
Bolt joint M6 ø16mm	118-1917	118-1918
Bolt joint ø1/4" ø16mm	118-1946	
Bolt joint ø1/4" ø19mm	118-1949	
Snap-on ø7,3 ø16mm	118-1947	118-1919

Application notes

Provision for PE Grounding is located at the PE Stamp on the compressor

Model

Designation	KLF6.6MFT	200-240V/50Hz	Conf. 1	Sales code:	106G2701
-------------	------------------	----------------------	----------------	-------------	-----------------

Configuration

Motorconfiguration	CSIR
Power supply (nominal)	200-240V/50Hz 1~
Refrigerant	R134a
Application	MBP
Voltage range	170-254V
Starting torque	HST
Approvals	VDE
	UL
	CCC

Electrical accessories / wiring diagram

CSIR



Ambient/ machine room temperatures minimum /maximum

Ambient temperature range:	10 - 43°C / 50 - 110°F
Machine room temperature range:	10 - 48°C / 50 - 119°F
Compressor cooling:	fan 3m/s

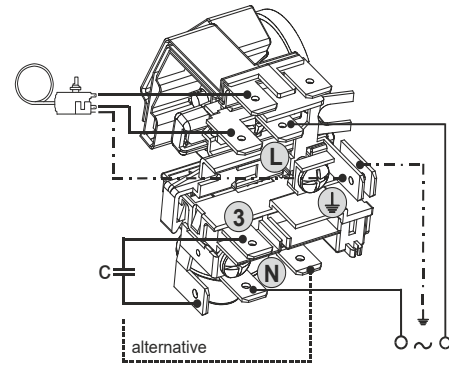

Operation pressure range

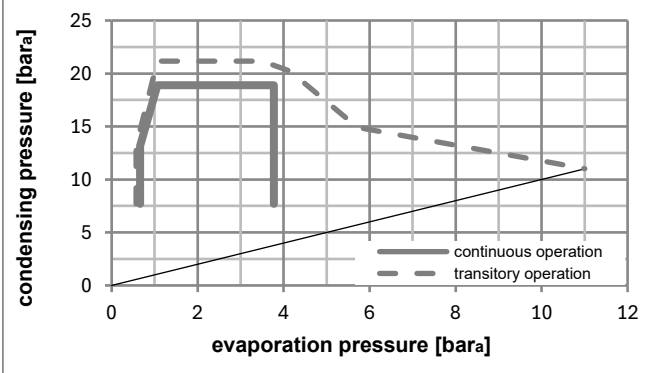
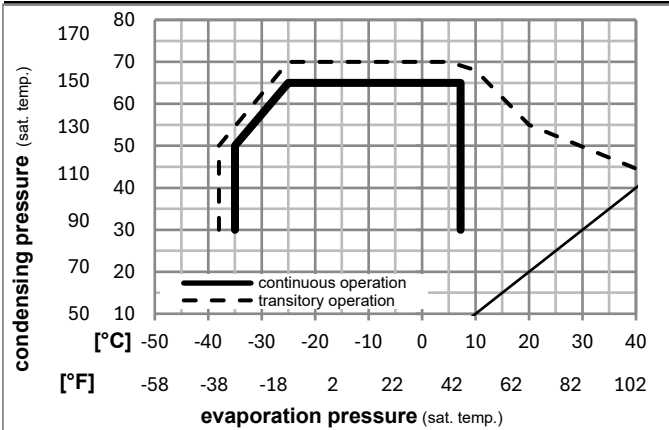

Components

a5	current relay (T0377/L6-S1)	117U7071
c	start capacitor (80µF, 6.3mm)	117U5001
b, d	cover + clamp + screws(5VA) in bag	103N1060

Alternative components

b, d	100x cover + clamp + screws(5VA)	103N2060
b, d	cover + clamp + screws(5VA-compl.)	103N0600

Model

Designation **KLF6.6MFT** **200-240V/50Hz** Conf. 1 Sales code: **106G2701**

Optimization + standard conditions

R134a, 200V/50Hz, CSIR, fan 3m/s, VDE, UL, CCC

	Evaporating pressure (saturation temperature)				Condensing pressure (saturation temperature)			Return gas temp.	Liquid temp.	Cooling capacity	COP	EER	Power consumption			Ref. mass flow
	pe	pc	RGT	Tliq	[W]	[Btu/h]	[kcal/h]						P1	I	m	
	[°C]	[°F]	[°C]	[°F]	[W]	[Btu/h]	[kcal/h]	[W/W]	[Btu/Wh]	[kcal/Wh]	[W]	[A]	[kg/h]			
ASHRAE LBP	-23	54	32	32	186,7	638	160,7	1,35	4,62	1,16	138,0	1,27	3,63			
	-10	130	90	90												
cecomaf LBP	-25	55	32	55	136,5	466	117,4	1,04	3,57	0,90	130,6	1,25	3,26			
	-13	131	90	131												
EN12900 LBP	-35	40	20	40	93,1	318	80,1	1,02	3,47	0,88	91,5	1,17	2,04			
	-31	104	68	104												
ASHRAE MBP	-7	54	35	46	401,5	1371	345,5	1,92	6,57	1,65	208,8	1,49	8,76			
	20	130	95	115												
cecomaf MBP	-10	55	32	55	309,8	1058	266,6	1,58	5,41	1,36	195,8	1,45	7,49			
	14	131	90	131												
EN12900 MBP	-10	45	20	45	347,3	1186	298,9	1,94	6,64	1,67	178,7	1,38	8,13			
	14	113	68	113												

Performance tables

R134a, 200V/50Hz, CSIR, fan 3m/s, VDE, UL, CCC

	pe		Cooling capacity			COP	EER	P1	I	m	
	[°C]	[°F]	[W]	[Btu/h]	[kcal/h]	[W/W]	[Btu/Wh]	[kcal/Wh]	[W]	[A]	[kg/h]
[°C / °F]	-30	-22	118,8	406	102,3	1,09	3,72	0,94	109,1	1,20	2,57
cond. pressure	-25	-13	161,0	550	138,6	1,27	4,33	1,09	126,9	1,24	3,49
pc= 45/113	-15	5	280,8	959	241,7	1,74	5,94	1,50	161,6	1,33	6,12
return gas temp.	-10	14	360,3	1230	310,1	2,02	6,88	1,73	178,7	1,38	7,89
RGT= 32/90	-5	23	454,0	1550	390,7	2,32	7,92	1,99	195,9	1,44	9,98
liquid temp	0	32	562,7	1922	484,3	2,64	9,02	2,27	213,1	1,51	12,45
Tliq= 45/113	7,2	45	747,8	2554	643,5	3,14	10,71	2,70	238,5	1,60	16,70
[°C / °F]	-30	-22	99,2	339	85,3	0,92	3,14	0,79	107,7	1,19	2,37
cond. pressure	-25	-13	136,5	466	117,4	1,04	3,57	0,90	130,6	1,25	3,26
pc= 55/131	-15	5	240,9	823	207,3	1,38	4,71	1,19	174,5	1,37	5,80
return gas temp	-10	14	309,8	1058	266,6	1,58	5,41	1,36	195,8	1,45	7,49
RGT= 32/90	-5	23	391,1	1336	336,6	1,80	6,16	1,55	216,7	1,52	9,51
liquid temp	0	32	485,6	1658	417,9	2,04	6,98	1,76	237,5	1,60	11,88
Tliq= 55/131	7,2	45	646,7	2209	556,5	2,42	8,26	2,08	267,3	1,72	15,99

Model

Designation	KLF6.6MFT	200-240V/50Hz	Conf. 2	Sales code:	106G2701
-------------	------------------	----------------------	----------------	-------------	-----------------

Configuration

Motorconfiguration	RSCR
Power supply (nominal)	200-240V/50Hz 1~
Refrigerant	R134a
Application	MBP
Voltage range	170-254V
Starting torque	LST
Approvals	VDE
	UL
	CCC

Electrical accessories / wiring diagram

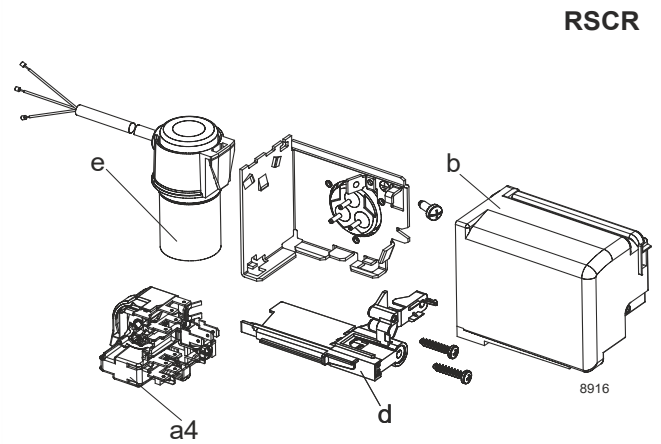

Ambient/ machine room temperatures minimum /maximum

Ambient temperature range:	10 - 43°C / 50 - 110°F
Machine room temperature range:	10 - 48°C / 50 - 119°F
Compressor cooling:	fan 3m/s

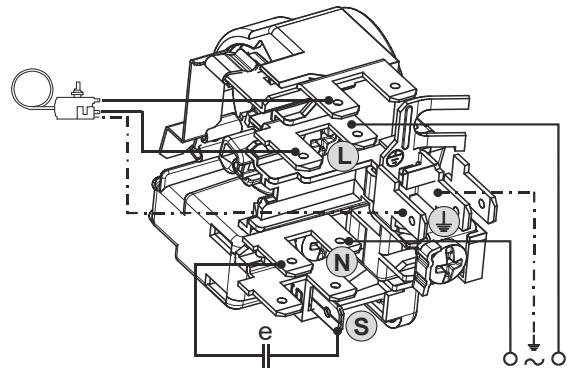

Operation pressure range

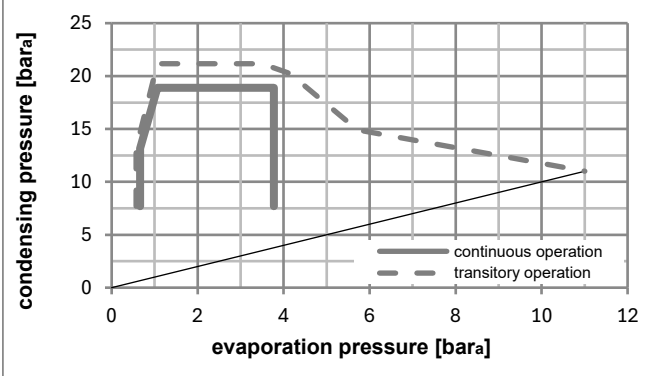
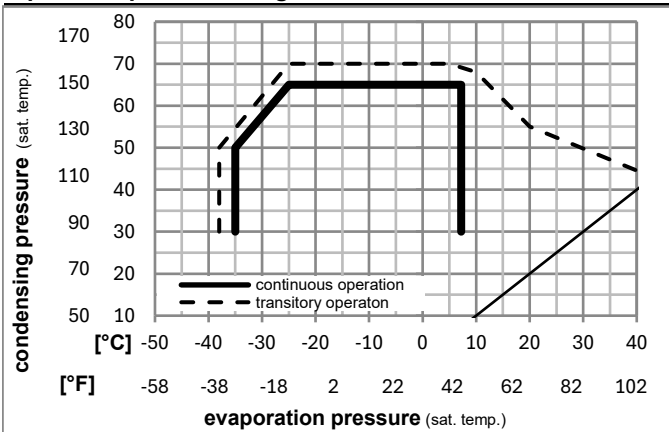

Components

a4	DAS1 (PTC,6.3mm, T0377/L6 - S1)	103N0250
e	run capacitor (5µF, 6.3mm)	117-7191
b, d	cover + clamp + screws(5VA) in bag	103N1060

Alternative components

a4	ZAS1 (PTC,4.8mm, T0377/L6 - S1)	103N0252
e	run capacitor (5µF, 4.8mm)	117-7190

b, d	100x cover + clamp + screws(5VA)	103N2060
b, d	cover + clamp + screws(5VA-compl.)	103N0600

Model

Designation **KLF6.6MFT** **200-240V/50Hz** Conf. 2 Sales code: **106G2701**

Optimization + standard conditions

R134a, 200V/50Hz, RSCR, fan 3m/s, VDE, UL, CCC

	Evaporating pressure (saturation temperature)				Cooling capacity			COP	EER	P1	Power consumption		ASHRAE LBP	
	pe	pc	RGT	Tliq	[W]	[Btu/h]	[kcal/h]				I	m		
	[°C]	[°F]	[°C]	[°F]	[W]	[Btu/h]	[kcal/h]	[W/W]	[Btu/Wh]	[kcal/Wh]	[W]	[A]	[kg/h]	
	-23	54	32	32	187,0	639	160,9	1,43	4,87	1,23	131,2	0,92	3,63	ASHRAE LBP
	-10	130	90	90										
	-25	55	32	55	136,7	467	117,6	1,10	3,76	0,95	124,1	0,90	3,27	cecomaf LBP
	-13	131	90	131										
	-35	40	20	40	93,1	318	80,2	1,08	3,68	0,93	86,4	0,78	2,04	EN12900 LBP
	-31	104	68	104										
	-7	54	35	46	402,4	1374	346,3	2,03	6,92	1,74	198,6	1,19	8,78	ASHRAE MBP
	20	130	95	115										
	-10	55	32	55	310,5	1060	267,2	1,67	5,69	1,43	186,2	1,14	7,51	cecomaf MBP
	14	131	90	131										
	-10	45	20	45	347,9	1188	299,4	2,04	6,98	1,76	170,2	1,07	8,14	EN12900 MBP
	14	113	68	113										

Performance tables

R134a, 200V/50Hz, RSCR, fan 3m/s, VDE, UL, CCC

	pe		Cooling capacity			COP	EER	P1	I	m	
	[°C]	[°F]	[W]	[Btu/h]	[kcal/h]						
[°C / °F]	-30	-22	119,0	406	102,4	1,15	3,93	0,99	103,5	0,83	2,57
cond. pressure	-25	-13	161,2	551	138,8	1,34	4,56	1,15	120,7	0,89	3,49
pc= 45/113	-15	5	281,3	961	242,1	1,83	6,24	1,57	153,9	1,01	6,13
return gas temp.	-10	14	361,0	1233	310,6	2,12	7,24	1,83	170,2	1,07	7,90
RGT= 32/90	-5	23	454,9	1554	391,5	2,44	8,33	2,10	186,4	1,14	10,00
liquid temp	0	32	564,1	1926	485,4	2,78	9,50	2,40	202,7	1,21	12,47
Tliq= 45/113	7,2	45	749,8	2561	645,3	3,31	11,31	2,85	226,5	1,32	16,75
[°C / °F]	-30	-22	99,3	339	85,4	0,97	3,32	0,84	102,1	0,82	2,37
cond. pressure	-25	-13	136,7	467	117,6	1,10	3,76	0,95	124,1	0,90	3,27
pc= 55/131	-15	5	241,3	824	207,7	1,45	4,96	1,25	166,1	1,05	5,81
return gas temp	-10	14	310,5	1060	267,2	1,67	5,69	1,43	186,2	1,14	7,51
RGT= 32/90	-5	23	392,0	1339	337,4	1,90	6,50	1,64	206,0	1,22	9,53
liquid temp	0	32	486,9	1663	419,0	2,16	7,37	1,86	225,6	1,31	11,91
Tliq= 55/131	7,2	45	648,8	2216	558,3	2,56	8,74	2,20	253,6	1,44	16,05

Model

Designation	KLF6.6MFT	208-230V/60Hz	Conf. 3	Sales code:	106G2701
-------------	------------------	----------------------	----------------	-------------	-----------------

Configuration

Motorconfiguration	CSIR
Power supply (nominal)	208-230V/60Hz 1~
Refrigerant	R134a
Application	MBP
Voltage range	198-253V
Starting torque	HST
Approvals	VDE
	UL
	CCC

Electrical accessories / wiring diagram

CSIR

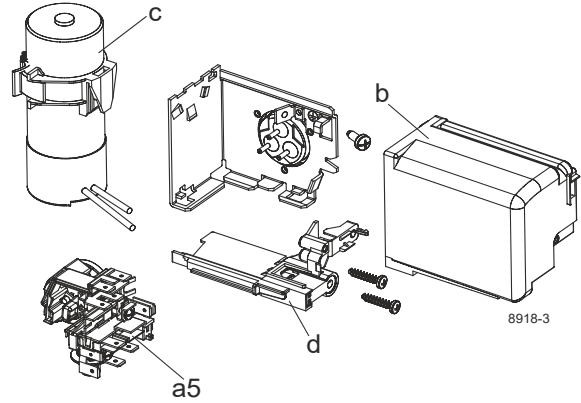

Ambient/ machine room temperatures minimum /maximum

Ambient temperature range: 10 - 43°C / 50 - 110°F

Machine room temperature range: 10 - 48°C / 50 - 119°F

Compressor cooling: fan 3m/s

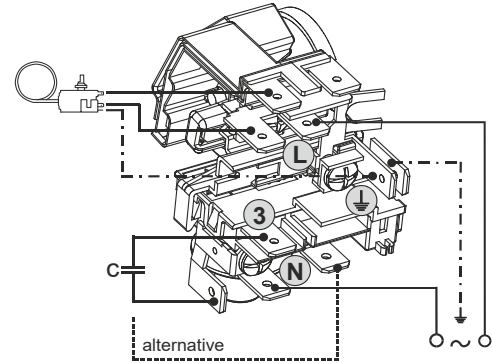

Operation pressure range

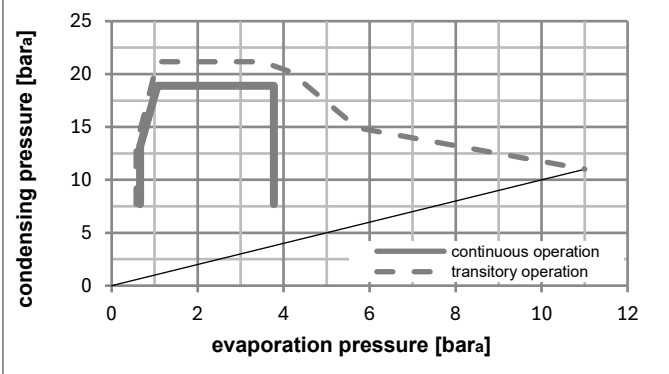
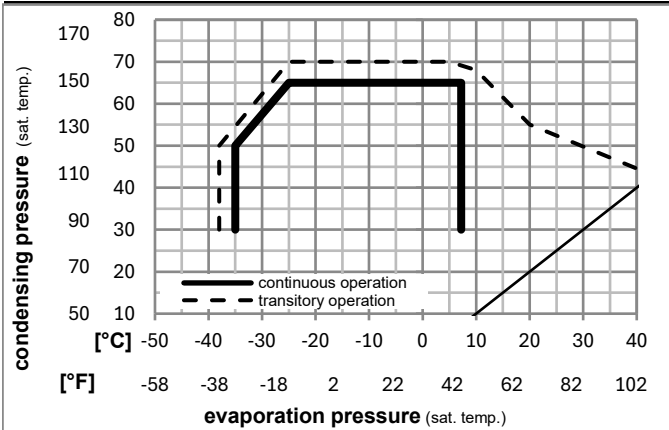

Components

a5	current relay (T0377/L6-S1)	117U7071
c	start capacitor (80µF, 6.3mm)	117U5001
b, d	cover + clamp + screws(5VA) in bag	103N1060

Alternative components

b, d	100x cover + clamp + screws(5VA)	103N2060
b, d	cover + clamp + screws(5VA-compl.)	103N0600

Model

Designation **KLF6.6MFT** **208-230V/60Hz** Conf. 3 Sales code: **106G2701**

Optimization + standard conditions

R134a, 208V/60Hz, CSIR, fan 3m/s, VDE, UL, CCC

	Evaporating pressure (saturation temperature)				Condensing pressure (saturation temperature)			Return gas temp.	Liquid temp.	Cooling capacity	COP	EER	Power consumption			Ref. mass flow
	pe	pc	RGT	Tliq	[W]	[Btu/h]	[kcal/h]						P1	I	m	
	[°C]	[°F]	[°C]	[°F]	[W]	[Btu/h]	[kcal/h]	[W/W]	[Btu/Wh]	[kcal/Wh]	[W]	[A]	[kg/h]			
ASHRAE LBP	-23	54	32	32	221,0	755	190,2	1,37	4,69	1,18	160,8	1,23	4,29			
	[°C]	[°F]	[°C]	[°F]	[W]	[Btu/h]	[kcal/h]	[W/W]	[Btu/Wh]	[kcal/Wh]	[W]	[A]	[kg/h]			
cecomaf LBP	-25	55	32	55	161,3	551	138,8	1,05	3,59	0,91	153,3	1,21	3,86			
	[°C]	[°F]	[°C]	[°F]	[W]	[Btu/h]	[kcal/h]	[W/W]	[Btu/Wh]	[kcal/Wh]	[W]	[A]	[kg/h]			
EN12900 LBP	-35	40	20	40	108,5	370	93,4	1,04	3,56	0,90	104,2	1,11	2,38			
	[°C]	[°F]	[°C]	[°F]	[W]	[Btu/h]	[kcal/h]	[W/W]	[Btu/Wh]	[kcal/Wh]	[W]	[A]	[kg/h]			
ASHRAE MBP	-7	54	35	46	474,8	1621	408,6	1,95	6,66	1,68	243,4	1,48	10,36			
	[°C]	[°F]	[°C]	[°F]	[W]	[Btu/h]	[kcal/h]	[W/W]	[Btu/Wh]	[kcal/Wh]	[W]	[A]	[kg/h]			
cecomaf MBP	-10	55	32	55	367,4	1255	316,2	1,61	5,51	1,39	227,7	1,43	8,88			
	[°C]	[°F]	[°C]	[°F]	[W]	[Btu/h]	[kcal/h]	[W/W]	[Btu/Wh]	[kcal/Wh]	[W]	[A]	[kg/h]			
EN12900 MBP	-10	45	20	45	405,5	1385	349,0	1,93	6,58	1,66	210,6	1,37	9,49			
	[°C]	[°F]	[°C]	[°F]	[W]	[Btu/h]	[kcal/h]	[W/W]	[Btu/Wh]	[kcal/Wh]	[W]	[A]	[kg/h]			

Performance tables

R134a, 208V/60Hz, CSIR, fan 3m/s, VDE, UL, CCC

	pe		Cooling capacity			COP	EER	P1	I	m	
	[°C]	[°F]	[W]	[Btu/h]	[kcal/h]	[W/W]	[Btu/Wh]	[kcal/Wh]	[W]	[A]	[kg/h]
[°C / °F]	-30	-22	137,5	470	118,3	1,11	3,80	0,96	123,5	1,14	2,97
cond. pressure	-25	-13	187,1	639	161,0	1,29	4,41	1,11	144,8	1,19	4,05
pc= 45/113	-15	5	327,7	1119	282,0	1,74	5,94	1,50	188,4	1,30	7,14
return gas temp.	-10	14	420,7	1437	362,1	2,00	6,82	1,72	210,6	1,37	9,21
RGT= 32/90	-5	23	530,2	1811	456,3	2,27	7,76	1,96	233,3	1,45	11,66
liquid temp	0	32	657,1	2244	565,5	2,56	8,76	2,21	256,3	1,52	14,53
Tliq= 45/113	7,2	45	872,5	2980	750,9	3,01	10,27	2,59	290,2	1,64	19,49
[°C / °F]	-30	-22	115,4	394	99,3	0,90	3,06	0,77	128,6	1,15	2,75
cond. pressure	-25	-13	161,3	551	138,8	1,05	3,59	0,91	153,3	1,21	3,86
pc= 55/131	-15	5	286,3	978	246,4	1,41	4,82	1,22	202,8	1,35	6,89
return gas temp	-10	14	367,4	1255	316,2	1,61	5,51	1,39	227,7	1,43	8,88
RGT= 32/90	-5	23	462,2	1579	397,8	1,83	6,25	1,57	252,7	1,51	11,24
liquid temp	0	32	571,7	1952	492,0	2,06	7,03	1,77	277,8	1,60	13,98
Tliq= 55/131	7,2	45	757,0	2585	651,5	2,41	8,22	2,07	314,4	1,73	18,72

Model

Designation	KLF6.6MFT	208-230V/60Hz	Conf. 4	Sales code:	106G2701
-------------	------------------	----------------------	----------------	-------------	-----------------

Configuration

Motorconfiguration	RSCR
Power supply (nominal)	208-230V/60Hz 1~
Refrigerant	R134a
Application	MBP
Voltage range	198-253V
Starting torque	LST
Approvals	VDE
	UL
	CCC

Electrical accessories / wiring diagram

RSCR

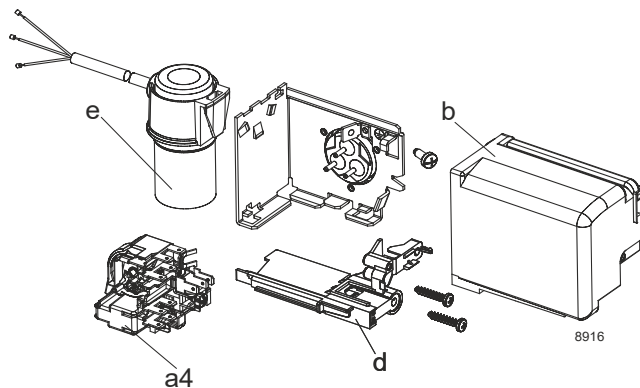

Ambient/ machine room temperatures minimum /maximum

Ambient temperature range: 10 - 43°C / 50 - 110°F

Machine room temperature range: 10 - 48°C / 50 - 119°F

Compressor cooling: fan 3m/s

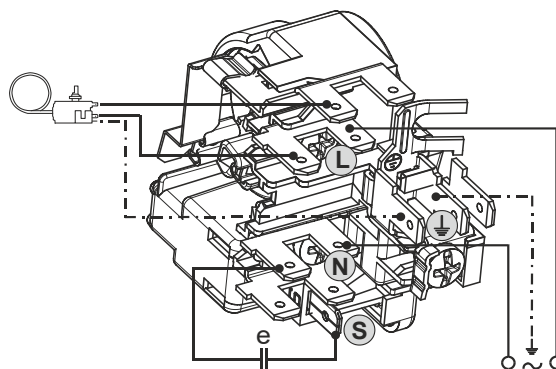

Operation pressure range

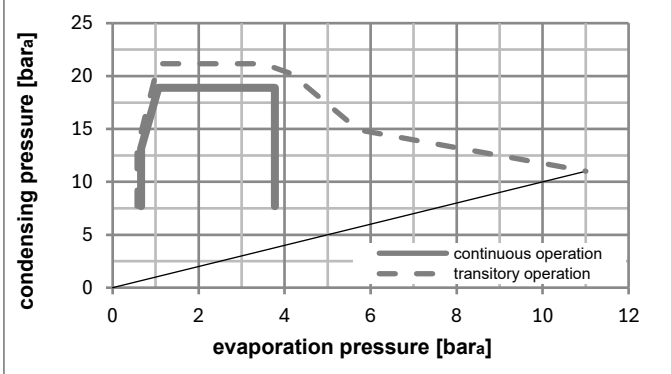
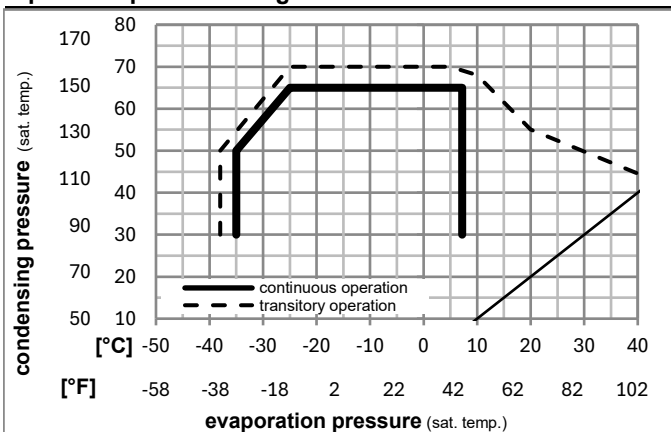

Components

a4	DAS1 (PTC,6.3mm, T0377/L6 - S1)	103N0250
e	run capacitor (5µF, 6.3mm)	117-7191
b, d	cover + clamp + screws(5VA) in bag	103N1060

Alternative components

a4	ZAS1 (PTC,4.8mm, T0377/L6 - S1)	103N0252
e	run capacitor (5µF, 4.8mm)	117-7190

b, d	100x cover + clamp + screws(5VA)	103N2060
b, d	cover + clamp + screws(5VA-compl.)	103N0600

Model

Designation **KLF6.6MFT** **208-230V/60Hz** Conf. 4 Sales code: **106G2701**

Optimization + standard conditions

R134a, 208V/60Hz, RSCR, fan 3m/s, VDE, UL, CCC

	Evaporating pressure (saturation temperature)				Condensing pressure (saturation temperature)			COP	EER			Power consumption			ASHRAE LBP
	pe	pc	RGT	Tliq	[W]	[Btu/h]	[kcal/h]		[W/W]	[Btu/Wh]	[kcal/Wh]	P1	I	m	
	[°C]	[°C]	[°C]	[°C]	[W]	[Btu/h]	[kcal/h]	[W/W]	[Btu/Wh]	[kcal/Wh]	[W]	[A]	[kg/h]		
	-23	54	32	32	221,3	756	190,5	1,44	4,91	1,24	153,8	0,80	4,30	ASHRAE LBP	
	[°F]	[°F]	[°F]	[°F]											
	-10	130	90	90											
	-25	55	32	55	161,5	551	139,0	1,10	3,76	0,95	146,7	0,77	3,86	cecomaf LBP	
	[°F]	[°F]	[°F]	[°F]											
	-13	131	90	131											
	-35	40	20	40	108,5	371	93,4	1,08	3,68	0,93	100,8	0,60	2,38	EN12900 LBP	
	[°F]	[°F]	[°F]	[°F]											
	-31	104	68	104											
	-7	54	35	46	475,8	1625	409,5	2,06	7,02	1,77	231,4	1,11	10,38	ASHRAE MBP	
	[°F]	[°F]	[°F]	[°F]											
	20	130	95	115											
	-10	55	32	55	368,1	1257	316,8	1,70	5,80	1,46	216,8	1,05	8,90	cecomaf MBP	
	[°F]	[°F]	[°F]	[°F]											
	14	131	90	131											
	-10	45	20	45	406,3	1388	349,7	2,03	6,92	1,74	200,6	0,98	9,51	EN12900 MBP	
	[°F]	[°F]	[°F]	[°F]											
	14	113	68	113											

Performance tables

R134a, 208V/60Hz, RSCR, fan 3m/s, VDE, UL, CCC

	pe		Cooling capacity			COP			EER			P1			I			m			
	[°C]	[°F]	[W]	[Btu/h]	[kcal/h]	[W/W]	[Btu/Wh]	[kcal/Wh]	[W]	[A]	[kg/h]	[W]	[A]	[kg/h]	[W]	[A]	[kg/h]	[W]	[A]	[kg/h]	
[°C / °F]	-30	-22	137,6	470	118,4	1,16	3,96	1,00	118,7	0,67	2,97										
cond. pressure	-25	-13	187,3	640	161,2	1,35	4,61	1,16	138,7	0,74	4,06										
pc= 45/113	-15	5	328,2	1121	282,5	1,83	6,24	1,57	179,6	0,90	7,15										
return gas temp.	-10	14	421,5	1440	362,8	2,10	7,18	1,81	200,6	0,98	9,23										
RGT= 32/90	-5	23	531,4	1815	457,3	2,40	8,18	2,06	221,8	1,07	11,68										
liquid temp	0	32	658,7	2250	566,9	2,71	9,24	2,33	243,3	1,16	14,57										
Tliq= 45/113	7,2	45	874,9	2988	753,0	3,18	10,87	2,74	274,8	1,29	19,54										
[°C / °F]	-30	-22	115,5	394	99,4	0,94	3,20	0,81	123,4	0,68	2,75										
cond. pressure	-25	-13	161,5	551	139,0	1,10	3,76	0,95	146,7	0,77	3,86										
pc= 55/131	-15	5	286,8	979	246,8	1,48	5,06	1,28	193,4	0,95	6,90										
return gas temp	-10	14	368,1	1257	316,8	1,70	5,80	1,46	216,8	1,05	8,90										
RGT= 32/90	-5	23	463,3	1582	398,7	1,93	6,59	1,66	240,1	1,14	11,26										
liquid temp	0	32	573,2	1957	493,3	2,18	7,43	1,87	263,4	1,24	14,02										
Tliq= 55/131	7,2	45	759,4	2593	653,5	2,56	8,73	2,20	297,0	1,38	18,78										

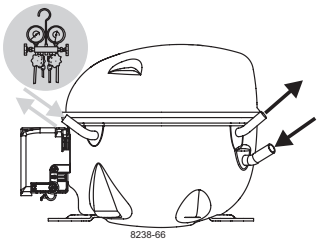

KL Compressors

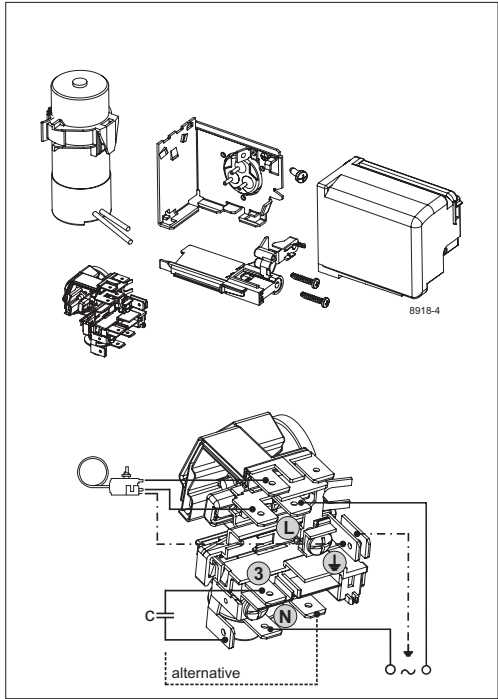
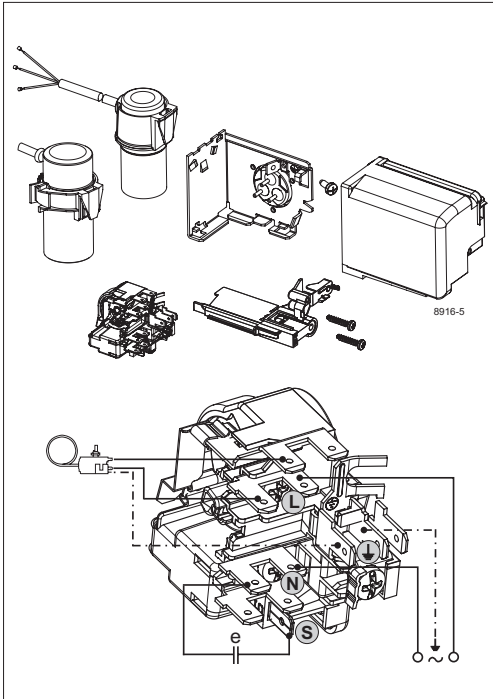
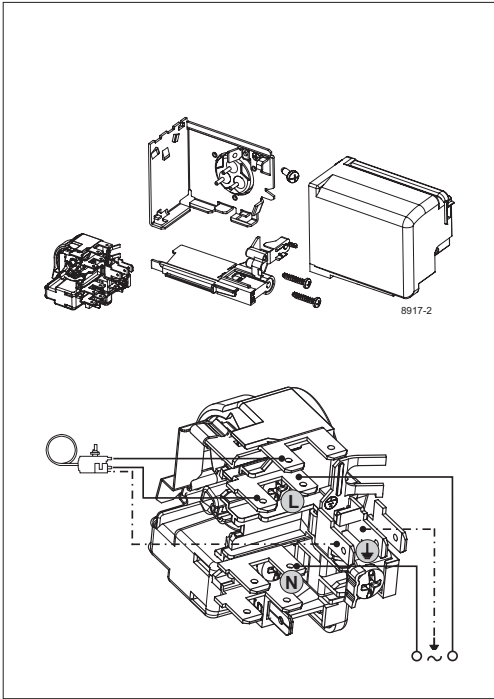

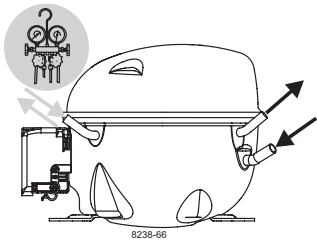

KL Compressors



Service/Repair – R290

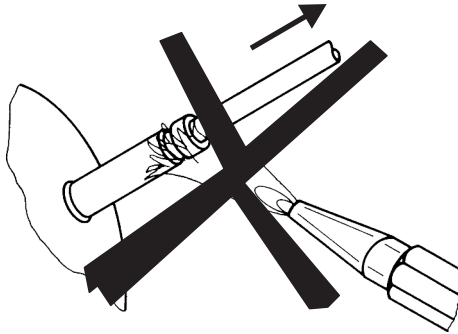

8545

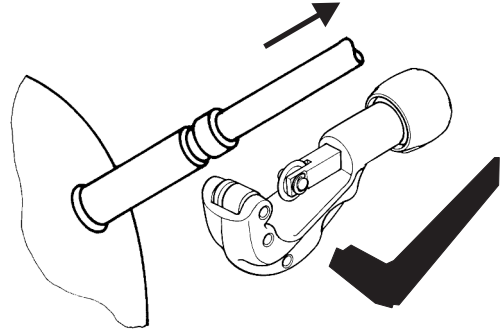

Secop accepts no responsibility for possible errors in catalogs, brochures, and other printed material. Secop reserves the right to alter its products without notice. This also applies to products already on order provided that such alterations can be made without subsequent changes being necessary to specifications already agreed. All trademarks in this material are the property of the respective companies. Secop and the Secop logotype are trademarks of Secop GmbH. All rights reserved. www.secop.com