

Single Pack KLF5.6CNT 200-240V 50Hz / 208-230V 60Hz CSIR

Single pack code number: **195B4700**

Position	Title	Code	Amount
1	Compressor KLF5.6CNT	106H2612	1
2	Bolt joint for one compressor M6 ø16mm	118-1917	1

Secop GmbH • Lise-Meitner-Straße 29 • 24941 Flensburg, Germany • Tel: +49 461 4941 0 • www.secop.com

Secop accepts no responsibility for possible errors in catalogs, brochures, and other printed material. Secop reserves the right to alter its products without notice. This also applies to products already on order provided that such alterations can be made without subsequent changes being necessary to specifications already agreed. All trademarks in this material are the property of the respective companies. Secop and the Secop logotype are trademarks of Secop GmbH. All rights reserved.

Model

Designation	KLF5.6CNT	200-240V/50Hz 1~ 208-230V/60Hz 1~	Sales code:	106H2612
-------------	------------------	-----------------------------------	-------------	-----------------

Compressor design

Oil type	Polyolester	Refrigerant(s)	R290
Oil viscosity	19,2cSt	Displacement	5,6cm ³ / 0,34cu.in
Oil quantity	162cm ³ / 5,5fl.oz	Compressors on pallet	100
Refr. charge - tech. limit	200g / 7,1oz		
Free gas volume comp.	1605cm ³ / 54,3fl.oz		
Weight	9,4kg / 20,7lbs		
Motor protection	external		
Winding resistance main	10,7Ω (at 25°C)		
Winding resistance aux	17Ω (at 25°C)		
Max. winding temp.	125°C / 257°F		
Max. discharge temp.	130°C / 266°F		



General - Configurations with KLF5.6CNT

	Conf. 1	Conf. 2
Motorconfiguration	CSIR	CSIR
Power supply (nominal)	200-240V/50Hz	208-230V/60Hz
Number of phases	1	1
Voltage range	187-254V	198-253V
Approvals	UL, CCC, CB	UL, CCC, CB
Starting torque	HST	HST
Note	Electrical equipment is included and pre-assembled to compressor.	

Applications with KLF5.6CNT

	Conf. 1	Conf. 2
Refrigerant	R290	R290
Application	LBP+MBP	LBP+MBP
System cooling	fan 3m/s	fan 3m/s
Hot gas defrost	OK	OK
Long interval pull down	OK	-/-

Electrical data - Configurations with KLF5.6CNT

	Conf. 1	Conf. 2
Starting device type	relay	relay
Run capacitor	-/-	-/-
Start capacitor	80μF	80μF
LRA (locked rotor amps / 4s/ U(N))	11,6A	11,6A
RLA (rated load amps / 1s/ U(N))	1,7A	1,7A
Cut in current (U(N))	10,3A	10,3A

Model

Designation	KLF5.6CNT	200-240V/50Hz 1~ 208-230V/60Hz 1~	Sales code:	106H2612
-------------	------------------	-----------------------------------	-------------	-----------------

Compressor dimensions

Housing	A Height	182mm / 7,17in
	B Height	175mm / 6,89in
	C Length shell	198mm / 7,8in
	D Length w. cover	238mm / 9,37in
	E Width	160mm / 6,3in

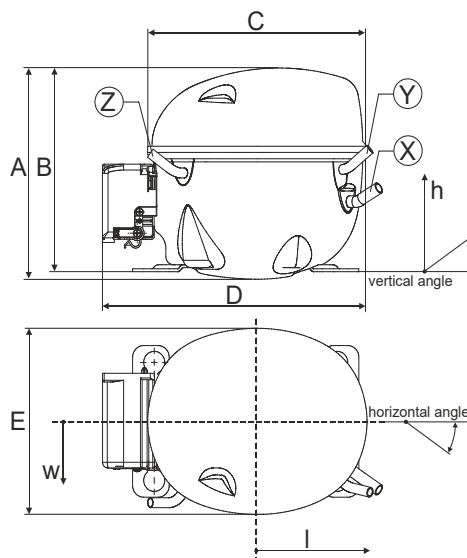

Connectors		Suction	Discharge	Process
		X	Y	Z
Diameter	[mm]	øi 8,11-8,29	øi 6,11-6,29	øi 6,11-6,29
(i:inside, o:outside)	[in]	øi 0,32-0,33	øi 0,24-0,25	øi 0,24-0,25
Material		copper	copper	copper
Horizontal angle	±2°	35°	13°	0°
Vertical angle	±2°	30°	40°	145°
Position l/h/w	[mm]	119/73/59	117/107/66	-88/101/71
	[in]	4,7/2,9/2,3	4,6/4,2/2,6	-3,5/4/2,8
Straight tube l.	[mm]	14	14	14
	[in]	0,5	0,5	0,5

Compressor fixation



Bolt joint

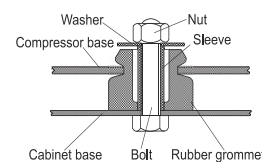

Snap-on

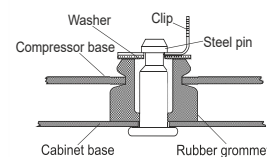

Mounting accessories	one comp.	multi pack
Bolt joint M6 ø16mm	118-1917	118-1918
Bolt joint ø1/4" ø16mm	118-1946	
Bolt joint ø1/4" ø19mm	118-1949	
Snap-on ø7,3 ø16mm	118-1947	118-1919

Application notes

Provision for PE Grounding is located at the PE Stamp on the compressor

Model

Designation	KLF5.6CNT	200-240V/50Hz	Conf. 1	Sales code:	106H2612
-------------	------------------	----------------------	----------------	-------------	-----------------

Configuration

Motorconfiguration	CSIR
Power supply (nominal)	200-240V/50Hz 1~
Refrigerant	R290
Application	LBP+MBP
Voltage range	187-254V
Starting torque	HST
Approvals	UL
	CCC
	CB

Electrical accessories / wiring diagram

CSIR



Ambient/ machine room temperatures minimum /maximum

Ambient temperature range:	10 - 43°C / 50 - 110°F
Machine room temperature range:	10 - 48°C / 50 - 119°F
Compressor cooling:	fan 3m/s

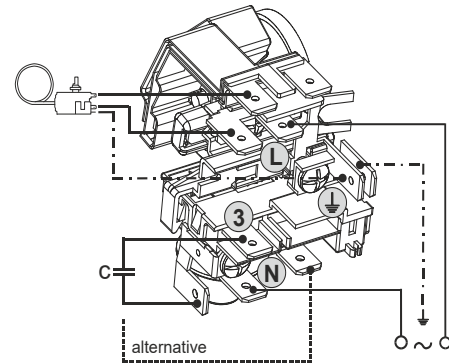

Operation pressure range

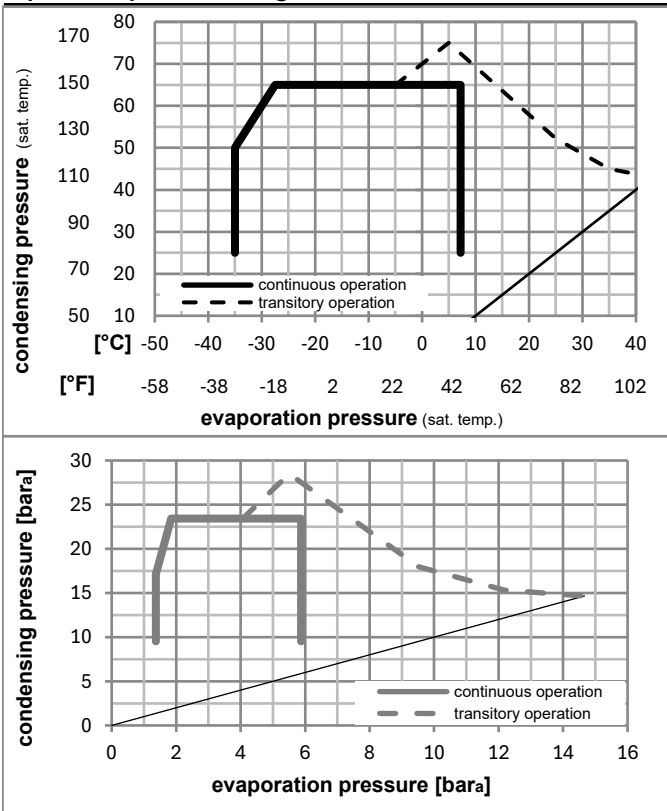

Components (already pre-assembled)

a5	current relay (1218/L6 - S7)	117U7077
c	start capacitor (80µF, 6.3mm)	117U5003
b	cover terminal board	10636401
.	screw uni en iso 4757	10641201

Alternative comp. (already pre-assembled)

.	cable clamp	16058100
.	screw - uni6954	10636000
.	screw - uni6954	10636200

Model

Designation **KLF5.6CNT** **200-240V/50Hz** Conf. 1 Sales code: **106H2612**

Optimization + standard conditions

R290, 220V/50Hz, CSIR, fan 3m/s, UL, CCC, CB

	Evaporating pressure (saturation temperature)				Cooling capacity			COP	EER	Power consumption			ASHRAE LBP	
	pe	pc	RGT	Tliq	[W]	[Btu/h]	[kcal/h]			P1	I	ṁ		
	[°C]	[°C]	[°C]	[°C]				[W/W]	[Btu/Wh]	[kcal/Wh]	[W]	[A]	[kg/h]	
	-23	54	32	32	270,9	925	233,2	1,54	5,26	1,33	175,9	1,22	2,74	ASHRAE LBP
	[°F]													
	-10	130	90	90										
	-25	55	32	55	201,7	689	173,6	1,19	4,06	1,02	169,6	1,20	2,51	cecomaf LBP
	[°F]													
	-13	131	90	131										
	-35	40	20	40	147,6	504	127,0	1,20	4,11	1,04	122,5	1,07	1,69	EN12900 LBP
	[°F]													
	-31	104	68	104										
	-7	54	35	46	489,9	1673	421,6	2,06	7,03	1,77	238,1	1,43	5,59	ASHRAE MBP
	[°F]													
	20	130	95	115										
	-10	55	32	55	388,3	1326	334,2	1,71	5,83	1,47	227,4	1,39	4,91	cecomaf MBP
	[°F]													
	14	131	90	131										
	-10	45	20	45	430,8	1471	370,7	2,08	7,10	1,79	207,2	1,32	5,29	EN12900 MBP
	[°F]													
	14	113	68	113										

Performance tables

R290, 220V/50Hz, CSIR, fan 3m/s, UL, CCC, CB

	pe		Cooling capacity			COP	EER	P1	I	m	
	[°C]	[°F]	[W]	[Btu/h]	[kcal/h]						
[°C / °F]	-35	-31	146,9	502	126,4	1,13	3,87	0,97	129,7	1,09	1,65
cond. pressure	-25	-13	238,6	815	205,4	1,48	5,06	1,27	161,1	1,17	2,69
pc= 45/113	-15	5	367,1	1254	316,0	1,91	6,51	1,64	192,6	1,27	4,18
return gas temp.	-10	14	448,4	1532	385,9	2,16	7,39	1,86	207,2	1,32	5,13
RGT= 32/90	-5	23	542,9	1854	467,2	2,46	8,42	2,12	220,3	1,36	6,25
liquid temp	0	32	651,7	2226	560,9	2,82	9,61	2,42	231,5	1,40	7,56
Tliq= 45/113	7,2	45	836,4	2856	719,8	3,44	11,74	2,96	243,3	1,45	9,83
[°C / °F]	-35	-31	112,9	386	97,2	0,85	2,92	0,74	132,1	1,09	1,40
cond. pressure	-25	-13	201,7	689	173,6	1,19	4,06	1,02	169,6	1,20	2,51
pc= 55/131	-15	5	317,2	1083	273,0	1,52	5,19	1,31	208,6	1,32	3,99
return gas temp	-10	14	388,3	1326	334,2	1,71	5,83	1,47	227,4	1,39	4,91
RGT= 32/90	-5	23	470,1	1605	404,5	1,92	6,55	1,65	245,1	1,45	5,99
liquid temp	0	32	563,7	1925	485,1	2,16	7,37	1,86	261,1	1,51	7,24
Tliq= 55/131	7,2	45	722,2	2466	621,5	2,57	8,79	2,22	280,5	1,59	9,41

Model

Designation	KLF5.6CNT	208-230V/60Hz	Conf. 2	Sales code:	106H2612
-------------	------------------	----------------------	----------------	-------------	-----------------

Configuration

Motorconfiguration	CSIR
Power supply (nominal)	208-230V/60Hz 1~
Refrigerant	R290
Application	LBP+MBP
Voltage range	198-253V
Starting torque	HST
Approvals	UL
	CCC
	CB

Electrical accessories / wiring diagram

CSIR

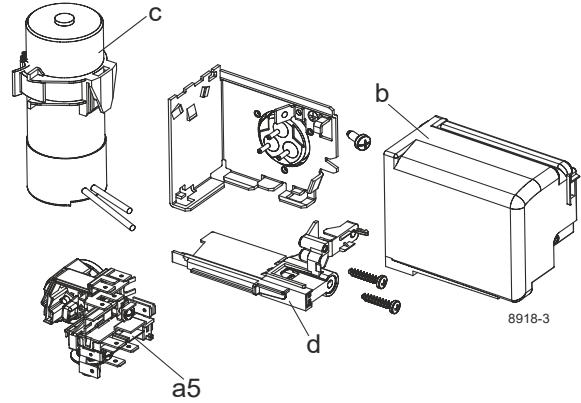

Ambient/ machine room temperatures minimum /maximum

Ambient temperature range:	10 - 43°C / 50 - 110°F
Machine room temperature range:	10 - 48°C / 50 - 119°F
Compressor cooling:	fan 3m/s

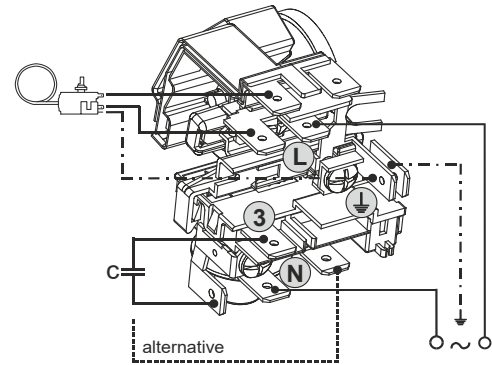

Operation pressure range

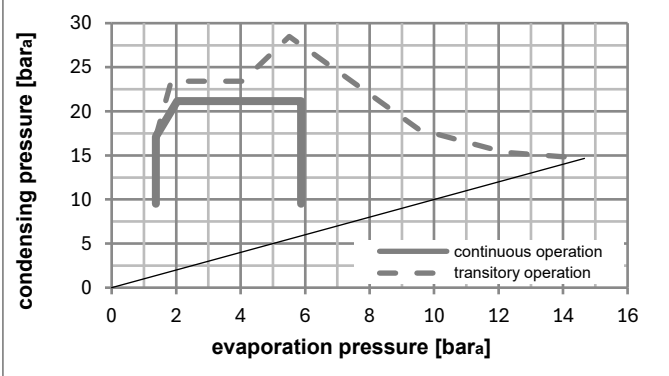
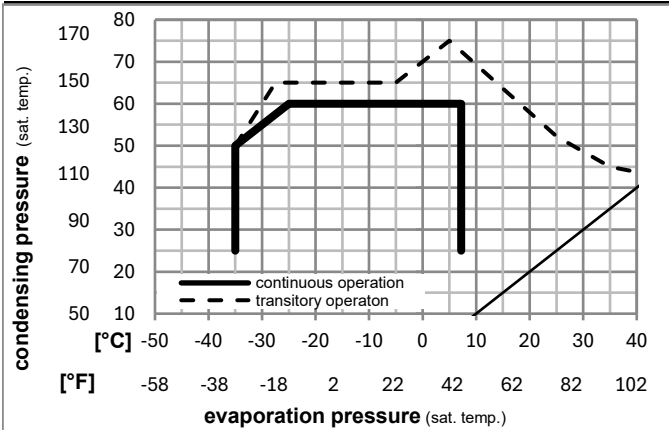

Components (already pre-assembled)

a5	current relay (1218/L6 - S7)	117U7077
c	start capacitor (80µF, 6.3mm)	117U5003
b	cover terminal board	10636401
.	screw uni en iso 4757	10641201

Alternative comp. (already pre-assembled)

.	cable clamp	16058100
.	screw - uni6954	10636000
.	screw - uni6954	10636200

Model

Designation **KLF5.6CNT** **208-230V/60Hz** Conf. 2 Sales code: **106H2612**

Optimization + standard conditions

R290, 230V/60Hz, CSIR, fan 3m/s, UL, CCC, CB

	Evaporating pressure (saturation temperature)				Cooling capacity			COP	EER			Power consumption			ASHRAE LBP
	pe	pc	RGT	Tliq	[W]	[Btu/h]	[kcal/h]		[W/W]	[Btu/Wh]	[kcal/Wh]	P1	I	m	
[°C]	-23	54	32	32	331,7	1133	285,5	1,58	5,39	1,36	210,2	1,34	3,36		
[°F]	-10	130	90	90											
[°C]	-25	55	32	55	248,5	849	213,9	1,23	4,21	1,06	201,8	1,32	3,09	cecomaf LBP	
[°F]	-13	131	90	131											
[°C]	-35	40	20	40	188,7	645	162,4	1,21	4,13	1,04	156,2	1,19	2,16	EN12900 LBP	
[°F]	-31	104	68	104											
[°C]	-7	54	35	46	604,1	2063	519,9	2,07	7,06	1,78	292,4	1,62	6,89	ASHRAE MBP	
[°F]	20	130	95	115											
[°C]	-10	55	32	55	478,0	1632	411,3	1,72	5,87	1,48	278,0	1,57	6,05	cecomaf MBP	
[°F]	14	131	90	131											
[°C]	-10	45	20	45	538,2	1838	463,2	2,08	7,11	1,79	258,5	1,50	6,61	EN12900 MBP	
[°F]	14	113	68	113											

Performance tables

R290, 230V/60Hz, CSIR, fan 3m/s, UL, CCC, CB

	pe		Cooling capacity			COP	EER		P1	I	m
	[°C]	[°F]	[W]	[Btu/h]	[kcal/h]	[W/W]	[Btu/Wh]	[kcal/Wh]	[W]	[A]	[kg/h]
[°C / °F]	-35	-31	180,4	616	155,3	1,14	3,90	0,98	157,8	1,20	2,02
cond. pressure	-25	-13	295,4	1009	254,3	1,49	5,09	1,28	198,3	1,31	3,33
pc= 45/113	-15	5	459,3	1569	395,3	1,92	6,55	1,65	239,6	1,44	5,23
return gas temp.	-10	14	560,3	1914	482,2	2,17	7,40	1,87	258,5	1,50	6,41
RGT= 32/90	-5	23	674,4	2303	580,4	2,45	8,37	2,11	275,1	1,56	7,76
liquid temp	0	32	801,9	2739	690,1	2,78	9,49	2,39	288,6	1,60	9,30
Tliq= 45/113	7,2	45	1009,6	3448	868,9	3,36	11,46	2,89	300,8	1,65	11,86
[°C / °F]	-35	-31	156,1	533	134,3	1,02	3,47	0,87	153,6	1,19	1,93
cond. pressure	-25	-13	248,5	849	213,9	1,23	4,21	1,06	201,8	1,32	3,09
pc= 55/131	-15	5	389,0	1328	334,8	1,54	5,25	1,32	253,2	1,48	4,89
return gas temp	-10	14	478,0	1632	411,3	1,72	5,87	1,48	278,0	1,57	6,05
RGT= 32/90	-5	23	579,8	1980	499,0	1,93	6,58	1,66	301,2	1,65	7,39
liquid temp	0	32	694,9	2373	598,0	2,16	7,37	1,86	321,8	1,73	8,93
Tliq= 55/131	7,2	45	884,3	3020	761,1	2,56	8,74	2,20	345,4	1,82	11,52



KL Compressors



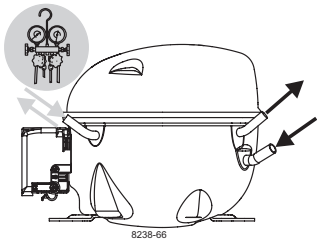

KL Compressors



Service/Repair – R290

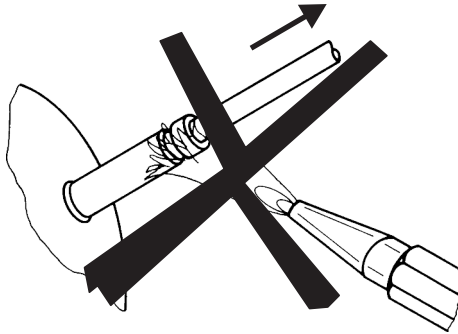

8545

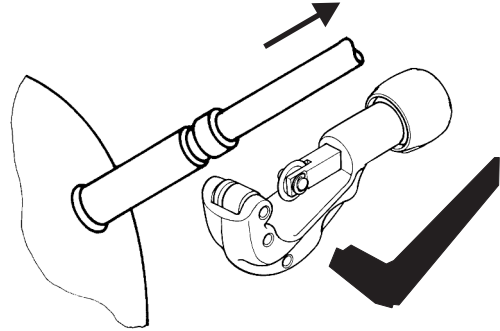

Secop accepts no responsibility for possible errors in catalogs, brochures, and other printed material. Secop reserves the right to alter its products without notice. This also applies to products already on order provided that such alterations can be made without subsequent changes being necessary to specifications already agreed. All trademarks in this material are the property of the respective companies. Secop and the Secop logotype are trademarks of Secop GmbH. All rights reserved. www.secop.com