

Single Pack KLE5.6GFTX 220-240V 50Hz / 208-230V 60Hz CSIR

Single pack code number: **195B4760**

Position	Title	Code	Amount
1	Compressor KLE5.6GFTX	106G5603	1
2	Starting capacitor (80 μ F 220V, 6.3mm)	117U5001	1
3	Starting relay (QLZ-4.4A, overload protector T0089/L6)	117U7070	1
4	KL accessories	103N1060	1
5	Bolt joint for one compressor M6 \varnothing 16mm	118-1917	1

Secop GmbH • Lise-Meitner-Straße 29 • 24941 Flensburg, Germany • Tel: +49 461 4941 0 • www.secop.com

Secop accepts no responsibility for possible errors in catalogs, brochures, and other printed material. Secop reserves the right to alter its products without notice. This also applies to products already on order provided that such alterations can be made without subsequent changes being necessary to specifications already agreed. All trademarks in this material are the property of the respective companies. Secop and the Secop logotype are trademarks of Secop GmbH. All rights reserved.

Model

Designation	KLE5.6GFTX	220-240V/50Hz 1~ 208-230V/60Hz 1~	Sales code:	106G5603
-------------	-------------------	-----------------------------------	-------------	-----------------

Compressor design

Oil type	Polyolester	Refrigerant(s)	R134a, R513A
Oil viscosity	19,2cSt	Displacement	5,6cm ³ / 0,34cu.in
Oil quantity	240cm ³ / 8,1fl.oz	Compressors on pallet	100
Refr. charge - tech. limit	250g / 8,8oz		
Free gas volume comp.	1535cm ³ / 51,9fl.oz		
Weight	9,5kg / 20,9lbs		
Motor protection	external		
Winding resistance main	10,7Ω (at 25°C)		
Winding resistance aux	17Ω (at 25°C)		
Max. winding temp.	125°C / 257°F		
Max. discharge temp.	130°C / 266°F		
Additional note	Good robustness against liquid intake. Ice-cube maker optimization - indirect suction intake.		



General - Configurations with KLE5.6GFTX

	Conf. 1	Conf. 2
Motorconfiguration	CSIR	CSIR
Power supply (nominal)	220-240V/50Hz	208-230V/60Hz
Number of phases	1	1
Voltage range	187-254V	198-253V
Approvals	VDE, (UL,CB) in progress	VDE, (UL,CB) in progress
Starting torque	HST	HST
Note	- / -	

Applications with KLE5.6GFTX

	Conf. 1	Conf. 2
Refrigerant	R134a	R134a
Application	LBP+MBP+HBP	LBP+MBP
System cooling	fan 3m/s	fan 3m/s
Hot gas defrost	OK	OK
Long interval pull down	OK	OK

Electrical data - Configurations with KLE5.6GFTX

	Conf. 1	Conf. 2
Starting device type	relay	relay
Run capacitor	-/-	-/-
Start capacitor	80μF	80μF
LRA (locked rotor amps / 4s/ U(N))	11,4A	
RLA (rated load amps / 1s/ U(N))	1,6A	
Cut in current (U(N))	10,7A	

Model

Designation	KLE5.6GFTX	220-240V/50Hz 1~ 208-230V/60Hz 1~	Sales code:	106G5603
-------------	-------------------	-----------------------------------	-------------	-----------------

Compressor dimensions

Housing	A Height	182mm / 7,17in
	B Height	175mm / 6,89in
	C Length shell	198mm / 7,8in
	D Length w. cover	238mm / 9,37in
	E Width	160mm / 6,3in

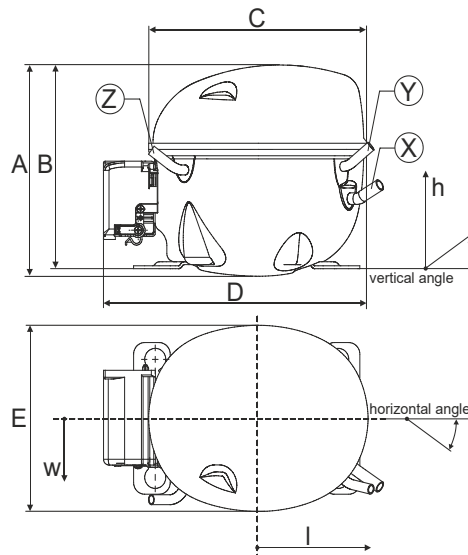

Connectors		Suction	Discharge	Process
		X	Y	Z
Diameter	[mm]	øi 8,11-8,29	øi 6,11-6,29	øi 6,11-6,29
(i:inside, o:outside)	[in]	øi 0,32-0,33	øi 0,24-0,25	øi 0,24-0,25
Material		copper	copper	copper
Horizontal angle	±2°	35°	13°	0°
Vertical angle	±2°	30°	40°	145°
Position l/h/w	[mm]	119/73/59	117/107/66	-88/101/71
	[in]	4,7/2,9/2,3	4,6/4,2/2,6	-3,5/4/2,8
Straight tube l.	[mm]	14	14	14
	[in]	0,5	0,5	0,5

Compressor fixation



Bolt joint

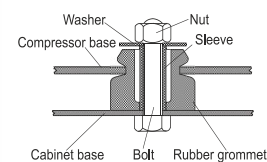

Snap-on

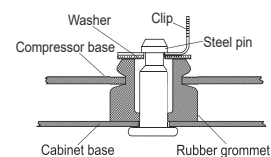

Mounting accessories	one comp.	multi pack
Bolt joint M6 ø16mm	118-1917	118-1918
Bolt joint ø1/4" ø16mm	118-1946	
Bolt joint ø1/4" ø19mm	118-1949	
Snap-on ø7,3 ø16mm	118-1947	118-1919

Application notes

Provision for PE Grounding is located at the PE Stamp on the compressor

Suctiongas connector and Process connector can be switched (minor loss of cooling capacity)

Model

Designation	KLE5.6GFTX	220-240V/50Hz	Conf. 1	Sales code:	106G5603
-------------	-------------------	----------------------	----------------	-------------	-----------------

Configuration

Motorconfiguration	CSIR
Power supply (nominal)	220-240V/50Hz 1~
Refrigerant	R134a
Application	LBP+MBP+HBP
Voltage range	187-254V
Starting torque	HST
Approvals	VDE (UL,CB) in progress

Electrical accessories / wiring diagram

CSIR

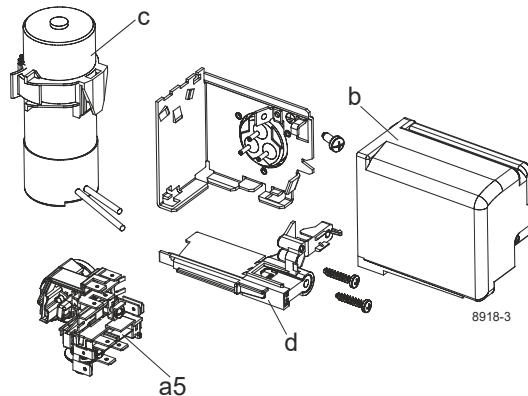

Ambient/ machine room temperatures minimum /maximum

Ambient temperature range: 10 - 43°C / 50 - 110°F

Machine room temperature range: 10 - 48°C / 50 - 119°F

Compressor cooling: fan 3m/s

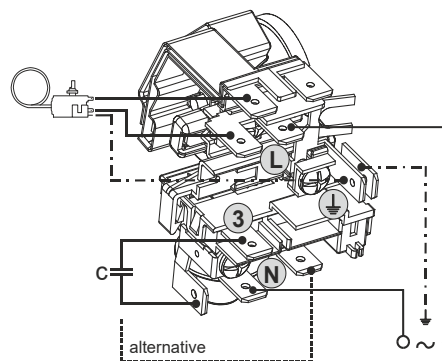

Operation pressure range

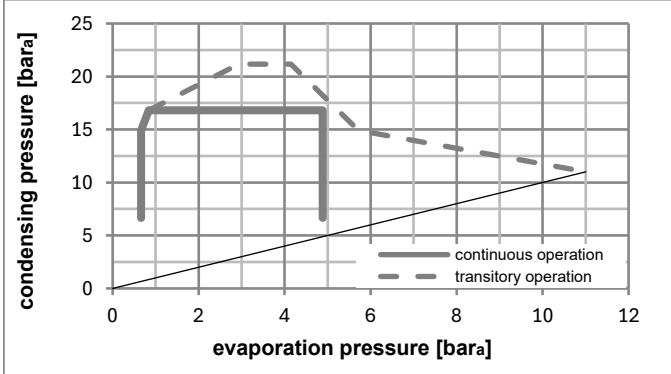
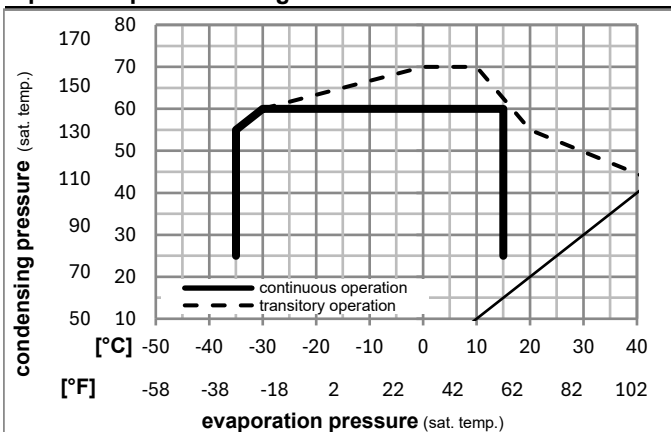

Components

a5	current relay (T0089/L6-S2)	117U7070
c	start capacitor (80μF, 6.3mm)	117U5001
b, d	cover + clamp + screws(5VA) in bag	103N1060

Alternative components

b, d	100x cover + clamp + screws(5VA)	103N2060
b, d	cover + clamp + screws(5VA-compl.)	103N0600

Model

Designation **KLE5.6GFTX 220-240V/50Hz** Conf. 1 Sales code: **106G5603**

Optimization + standard conditions

R134a, 220V/50Hz, CSIR, fan 3m/s, VDE, (UL,CB) in progress

	Evaporating pressure (saturation temperature)				Condensing pressure (saturation temperature)			Return gas temp.			Liquid temp.			Cooling capacity			COP	EER	Power consumption			
	pe	pc	RGT	Tliq	[W]	[Btu/h]	[kcal/h]	[W/W]	[Btu/Wh]	[kcal/Wh]	P1	I	m	[W]	[A]	[kg/h]						
[°C]																						
[°F]																						
	-23	54	32	32	156,4	534	134,6	1,32	4,51	1,14	118,5	1,22	3,04									
	-10	130	90	90																		
	-7	54	35	46	335,5	1146	288,7	1,92	6,55	1,65	174,9	1,37	7,32									
	20	130	95	115																		
	7,2	54	35	46	601,5	2054	517,6	2,74	9,35	2,36	219,7	1,53	13,34									
	45	130	95	115																		
	-35	40	20	40	81,5	278	70,1	0,98	3,36	0,85	82,8	1,15	1,79									
	-31	104	68	104																		
	-10	45	20	45	289,8	990	249,4	1,92	6,56	1,65	150,8	1,30	6,78									
	14	113	68	113																		
	5	50	20	50	513,1	1752	441,6	2,52	8,62	2,17	203,2	1,47	12,93									
	41	122	68	122																		

Performance tables

R134a, 220V/50Hz, CSIR, fan 3m/s, VDE, (UL,CB) in progress

	pe		Cooling capacity			COP	EER		P1	I	m
	[°C]	[°F]	[W]	[Btu/h]	[kcal/h]	[W/W]	[Btu/Wh]	[kcal/Wh]	[W]	[A]	[kg/h]
[°C / °F]	-35	-31	76,7	262	66,0	0,93	3,18	0,80	82,3	1,15	1,65
cond. pressure	-25	-13	135,0	461	116,2	1,23	4,21	1,06	109,5	1,20	2,93
pc= 45/113	-15	5	234,2	800	201,5	1,71	5,84	1,47	137,0	1,26	5,10
return gas temp.	-10	14	300,6	1027	258,7	1,99	6,81	1,72	150,8	1,30	6,58
RGT= 32/90	0	32	470,6	1607	405,0	2,64	9,00	2,27	178,5	1,38	10,41
liquid temp	5	41	575,3	1965	495,1	2,99	10,21	2,57	192,4	1,43	12,81
Tliq= 45/113	15	59	827,6	2827	712,3	3,76	12,85	3,24	220,0	1,54	18,75
[°C / °F]	-35	-31	62,9	215	54,1	0,81	2,78	0,70	77,2	1,13	1,50
cond. pressure	-25	-13	114,7	392	98,7	1,02	3,47	0,88	112,7	1,20	2,74
pc= 55/131	-15	5	201,0	686	173,0	1,36	4,66	1,17	147,4	1,29	4,84
return gas temp	-10	14	258,7	883	222,6	1,57	5,37	1,35	164,4	1,34	6,25
RGT= 32/90	0	32	406,4	1388	349,7	2,06	7,02	1,77	197,7	1,45	9,94
liquid temp	5	41	497,7	1700	428,3	2,33	7,95	2,00	213,9	1,51	12,26
Tliq= 55/131	15	59	718,4	2453	618,2	2,93	10,00	2,52	245,3	1,64	18,04

Model

Designation	KLE5.6GFTX	208-230V/60Hz	Conf. 2	Sales code:	106G5603
-------------	-------------------	----------------------	----------------	-------------	-----------------

Configuration

Motorconfiguration	CSIR
Power supply (nominal)	208-230V/60Hz 1~
Refrigerant	R134a
Application	LBP+MBP
Voltage range	198-253V
Starting torque	HST
Approvals	VDE (UL,CB) in progress

Electrical accessories / wiring diagram

CSIR

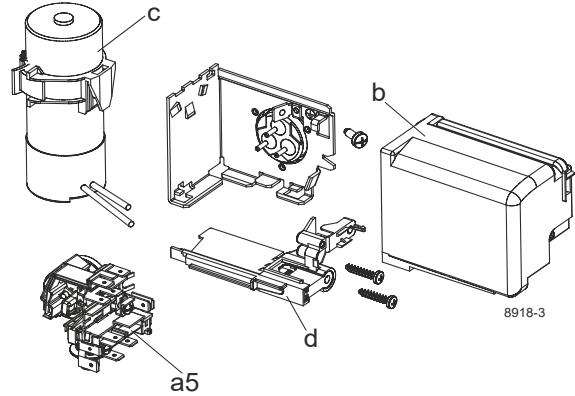

Ambient/ machine room temperatures minimum /maximum

Ambient temperature range:	10 - 43°C / 50 - 110°F
Machine room temperature range:	10 - 48°C / 50 - 119°F
Compressor cooling:	fan 3m/s

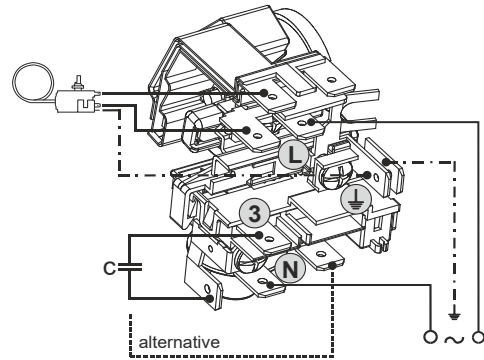

Operation pressure range

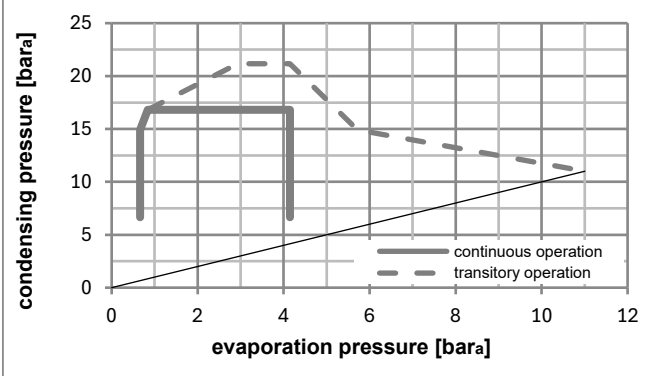
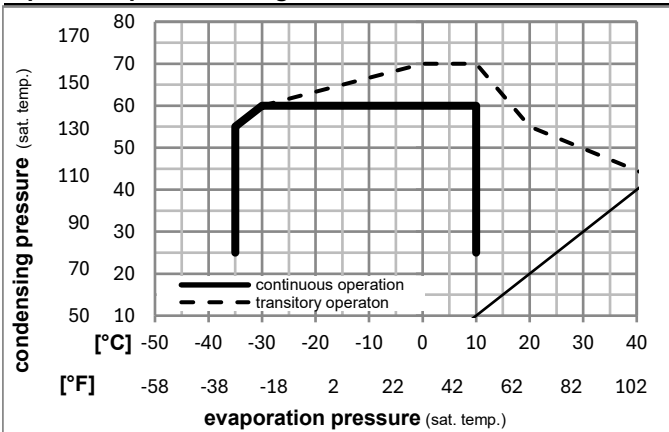

Components

a5	current relay (T0089/L6-S2)	117U7070
c	start capacitor (80µF, 6.3mm)	117U5001
b, d	cover + clamp + screws(5VA) in bag	103N1060

Alternative components

b, d	100x cover + clamp + screws(5VA)	103N2060
b, d	cover + clamp + screws(5VA-compl.)	103N0600

Model

Designation **KLE5.6GFTX** **208-230V/60Hz** Conf. 2 Sales code: **106G5603**

Optimization + standard conditions

R134a, 230V/60Hz, CSIR, fan 3m/s, VDE, (UL,CB) in progress

	Evaporating pressure (saturation temperature)				Condensing pressure (saturation temperature)			Return gas temp.	Liquid temp.	Cooling capacity	COP	EER	Power consumption			Ref. mass flow
	pe	pc	RGT	Tliq	[W]	[Btu/h]	[kcal/h]						P1	I	m	
[°C]																
[°F]	-23	54	32	32	192,7	658	165,9	1,37	4,69	1,18	140,3	1,18	3,74	ASHRAE LBP		
	-10	130	90	90												
[°C]	-7	54	35	46	396,6	1354	341,3	1,95	6,65	1,68	203,6	1,35	8,65	ASHRAE MBP		
[°F]	20	130	95	115												
[°C]	7,2	54	35	46	702,9	2401	605,0	2,73	9,31	2,35	257,8	1,53	15,59	ASHRAE HBP		
[°F]	45	130	95	115												
[°C]	-35	40	20	40	99,0	338	85,2	1,07	3,66	0,92	92,3	1,09	2,17	EN12900 LBP		
[°F]	-31	104	68	104												
[°C]	-10	45	20	45	340,9	1164	293,4	1,91	6,54	1,65	178,1	1,27	7,98	EN12900 MBP		
[°F]	14	113	68	113												
[°C]	5	50	20	50	598,3	2043	514,9	2,48	8,46	2,13	241,6	1,47	15,08	EN12900 HBP		
[°F]	41	122	68	122												

Performance tables

R134a, 230V/60Hz, CSIR, fan 3m/s, VDE, (UL,CB) in progress

	pe		Cooling capacity			COP	EER	P1	I	m	
	[°C]	[°F]	[W]	[Btu/h]	[kcal/h]	[W/W]	[Btu/Wh]				[kcal/Wh]
[°C / °F]	-35	-31	92,3	315	79,4	1,01	3,46	0,87	91,2	1,08	1,99
cond. pressure	-25	-13	165,3	565	142,3	1,30	4,43	1,12	127,3	1,15	3,58
pc= 45/113	-15	5	278,6	951	239,7	1,73	5,90	1,49	161,3	1,23	6,07
return gas temp.	-10	14	353,6	1208	304,3	1,99	6,78	1,71	178,1	1,27	7,74
RGT= 32/90	0	32	547,6	1870	471,2	2,57	8,79	2,21	212,8	1,38	12,11
liquid temp	5	41	669,1	2285	575,8	2,89	9,88	2,49	231,2	1,44	14,90
Tliq= 45/113	15	59	968,2	3307	833,3	3,57	12,18	3,07	271,5	1,57	21,93
[°C / °F]	-35	-31	72,1	246	62,1	0,78	2,66	0,67	92,6	1,08	1,72
cond. pressure	-25	-13	141,6	484	121,9	1,05	3,60	0,91	134,3	1,16	3,39
pc= 55/131	-15	5	242,5	828	208,7	1,40	4,79	1,21	172,9	1,26	5,84
return gas temp	-10	14	308,1	1052	265,1	1,61	5,49	1,38	191,8	1,31	7,45
RGT= 32/90	0	32	476,4	1627	410,0	2,07	7,08	1,78	229,8	1,43	11,65
liquid temp	5	41	581,9	1987	500,8	2,33	7,96	2,01	249,6	1,50	14,34
Tliq= 55/131	15	59	842,3	2877	724,9	2,88	9,85	2,48	292,0	1,65	21,16



KL Compressors



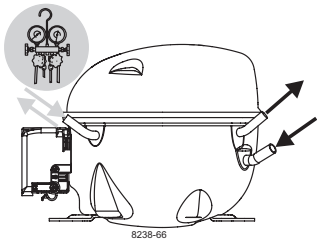

KL Compressors



Service/Repair – R290

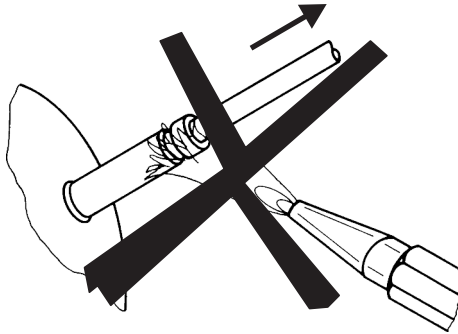

8545

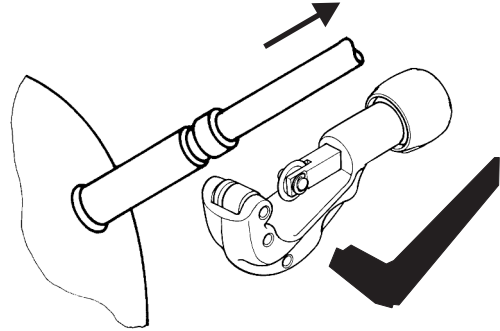

Secop accepts no responsibility for possible errors in catalogs, brochures, and other printed material. Secop reserves the right to alter its products without notice. This also applies to products already on order provided that such alterations can be made without subsequent changes being necessary to specifications already agreed. All trademarks in this material are the property of the respective companies. Secop and the Secop logotype are trademarks of Secop GmbH. All rights reserved. www.secop.com