

Single Pack BDN50K 12/24V DC PM

Single pack code number: **195B3448**

Position	Title	Code	Amount
1	Compressor BDN50K	109Z0420	1
2	Electronic unit - Leisure BD	101N2741	1
3	Snap-on for one compressor $\varnothing 7$ $\varnothing 17.5\text{mm}$	118-1959	1

Secop GmbH • Lise-Meitner-Straße 29 • 24941 Flensburg, Germany • Tel: +49 461 4941 0 • www.secop.com

Secop accepts no responsibility for possible errors in catalogs, brochures, and other printed material. Secop reserves the right to alter its products without notice. This also applies to products already on order provided that such alterations can be made without subsequent changes being necessary to specifications already agreed. All trademarks in this material are the property of the respective companies. Secop and the Secop logotype are trademarks of Secop GmbH. All rights reserved.

BDN50K Direct Current Compressor R600a 12/24V DC



General

Code number (without electronic unit)	109Z0420
Electronic unit - Leisure	101N2740, 40 pcs: 101N2741
Compressors on pallet	240

Approvals

UL / CB

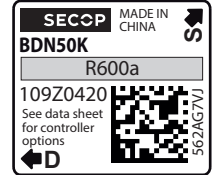

Application

Application range	LBP/MBP
Voltage range	VDC 9.6 - 17 / 19 - 34

Cooling requirements

Application	LBP	MBP
32°C / 38°C / 43°C	S	S

Absolute maximum ratings

Machine compartment temperature for compressor operation	°C	-10 to 50
Max. compressor tilt angle for temporary operation		±30°
Operating pressure range		see diagram to the right
Any levels of stress exceeding the absolute maximum value of machine compartment temperature range or operating pressure range or tilt angle may damage the device. Prolonged exposure to stress above the recommended operating conditions may also affect the device's reliability.		

Motor

Motor type	permanet magnet, brushless DC
Speed	rpm variable speed
Resistance, each of the three windings (25°C)	Ω 3.1

Design

Displacement	cm ³	2.60
Oil quantity (type)	cm ³	53 (polyolester)
Maximum refrigerant charge	g	70
Free gas volume in compressor	cm ³	472
Weight - Compressor/Electronic unit	kg	1.37 / 0.14

Standard battery protection settings

Voltage (0.1 steps)				Default	Min. value	Max. value
12V	± 0.3V DC, all values	Cut out level	VDC	10.4	9.6	17
24V	± 0.3V DC, all values	Cut out level	VDC	21.3	19	32
Battery cut-in difference			VDC	1.3	0.5	10

Dimensions

Height	mm	A	89.0
		B	82.4
		B1	48.7
		B2	45.8
Suction connector	location/I.D. mm angle	C	6.2 5°
	material comment		Copper Rubber plug
Process connector	location/I.D. mm angle	D	6.2 77.9°
	material comment		Copper Rubber plug
Discharge connector	location/I.D. mm angle	E	5.0 86.9°
	material comment		Cu-plated steel Rubber plug
Connector tolerance	I.D. mm		±0.09, on 5.0 +0.12/+0.20
Remarks: Please follow the brazing instructions on page 3 (Product Bulletin DES.N.101.M1).			



Approvals and warning label

S = Static cooling normally sufficient

Note: In case fan cooling is used:

condenser => fan => electronic => compressor

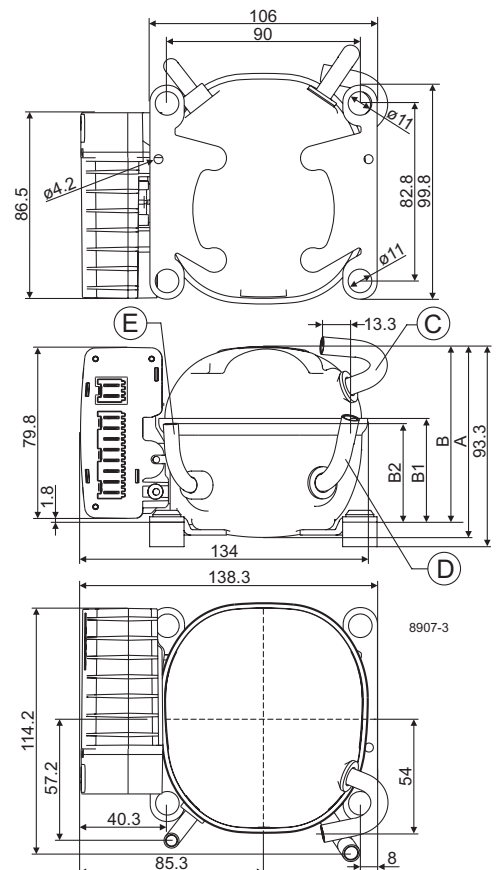
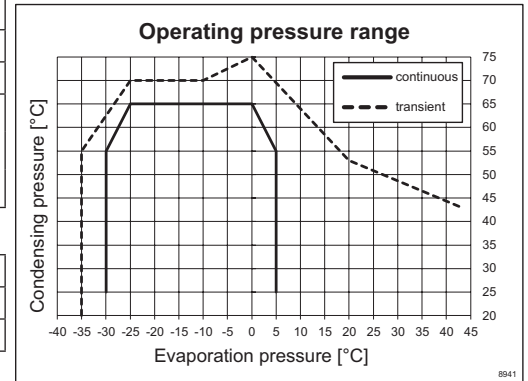

Capacity (EN 12900 Household/CECOMAF) 12V DC, static cooling **watt**

rpm \ °C	-30	-25	-23.3	-20	-15	-10	-5	0	5
2,300	16.8	23.3	25.9	31.3	40.9	52.2	65.4	80.5	97.7
3,000	23.8	32.6	35.9	43.0	55.4	70.0	87.0	106.8	
4,000	32.5	44.7	49.2	58.9	75.8	95.7	119.1	146.4	
4,500	36.0	50.2	55.3	65.5	82.8	103.2	127.9		

Capacity (ASHRAE LBP) 12V DC, static cooling **watt**

rpm \ °C	-30	-25	-23.3	-20	-15	-10	-5	0	5
2,300	20.6	28.5	31.6	38.3	50.0	63.8	79.9	98.4	119.4
3,000	29.3	39.9	43.9	52.6	67.6	85.4	106.2	130.4	
4,000	39.8	54.6	60.2	72.0	92.6	116.9	145.5	178.9	
4,500	44.6	62.0	68.1	80.6	101.6	126.5	156.4		

Power consumption 12V DC, static cooling **watt**

rpm \ °C	-30	-25	-23.3	-20	-15	-10	-5	0	5
2,300	16.8	20.2	21.4	24.0	28.2	32.5	36.8	41.1	45.1
3,000	21.9	26.6	28.2	31.3	36.1	40.9	45.6	50.2	
4,000	30.1	36.9	39.3	43.8	50.6	57.4	64.3	71.2	
4,500	34.4	41.8	44.3	49.0	56.0	62.9	69.7		

Current consumption (for 24V applications the following must be halved)

rpm \ °C	-30	-25	-23.3	-20	-15	-10	-5	0	5
2,300	1.40	1.68	1.79	2.00	2.35	2.71	3.07	3.42	3.76
3,000	1.82	2.22	2.35	2.61	3.01	3.41	3.80	4.19	
4,000	2.51	3.08	3.27	3.65	4.22	4.79	5.36	5.93	
4,500	2.87	3.49	3.69	4.09	4.67	5.24	5.80		

COP (EN 12900 Household/CECOMAF) 12V DC, static cooling **W/W**

rpm \ °C	-30	-25	-23.3	-20	-15	-10	-5	0	5
2,300	1.00	1.16	1.21	1.30	1.45	1.61	1.78	1.96	2.17
3,000	1.09	1.23	1.27	1.37	1.53	1.71	1.91	2.13	
4,000	1.08	1.21	1.25	1.35	1.50	1.67	1.85	2.06	
4,500	1.05	1.20	1.25	1.34	1.48	1.64	1.84		

COP (ASHRAE LBP) 12V DC, static cooling **W/W**

rpm \ °C	-30	-25	-23.3	-20	-15	-10	-5	0	5
2,300	1.24	1.42	1.48	1.60	1.79	1.98	2.18	2.41	2.67
3,000	1.33	1.50	1.56	1.68	1.88	2.10	2.34	2.61	
4,000	1.32	1.48	1.53	1.65	1.83	2.04	2.27	2.53	
4,500	1.30	1.48	1.54	1.64	1.82	2.02	2.25		

Operational errors (TOOL4COOL® or LED flashes)

Error code or LED flashes	Error type
	Can be read out in the software TOOL4COOL®
7	Communication error (Communication of master controller stopped for 15 minutes (default))
6	Thermostat failure (If a NTC thermistor is short-circuit or has no connection, the electronic unit will enter manual mode).
5	Thermal cut-out of electronic unit (PCB or machine compartment temperature exceeds minimum or maximum limits).
4	Minimum motor speed error (If the refrigeration system is too heavily loaded, the motor cannot maintain min. speed at approximately 2,150 rpm).
3	Motor start error (The rotor is blocked or the differential pressure in the refrigeration system is too high (>5 bar)).
2	Fan over-current cut-out (The fan is overloading the electronic unit).
1	Battery protection cut-out (The voltage is outside the cut-out setting).

A Wire Dimensions DC

Cross section [mm ²]	Size AWG [Gauge]	Max. length* 12V operation		Max. length* 24V operation	
		[m]	[ft.]	[m]	[ft.]
2.5	12	2.5	8	5	16
4	12	4	13	8	26
6	10	6	20	12	39
10	8	10	33	20	66

*Length between battery and electronic unit

Accessories for BDN50K

Mounting	Code number
Bolt joint for one compressor	118-1960
Snap-on for one compressor	118-1959
Secop Gateway	105N9518

Test conditions	EN 12900 CECOMAF	ASHRAE LBP
Condensing temperature	55°C	54.4°C
Ambient temperature	32°C	32°C
Suction gas temperature	32°C	32°C
Liquid temperature	no subcooling	32°C

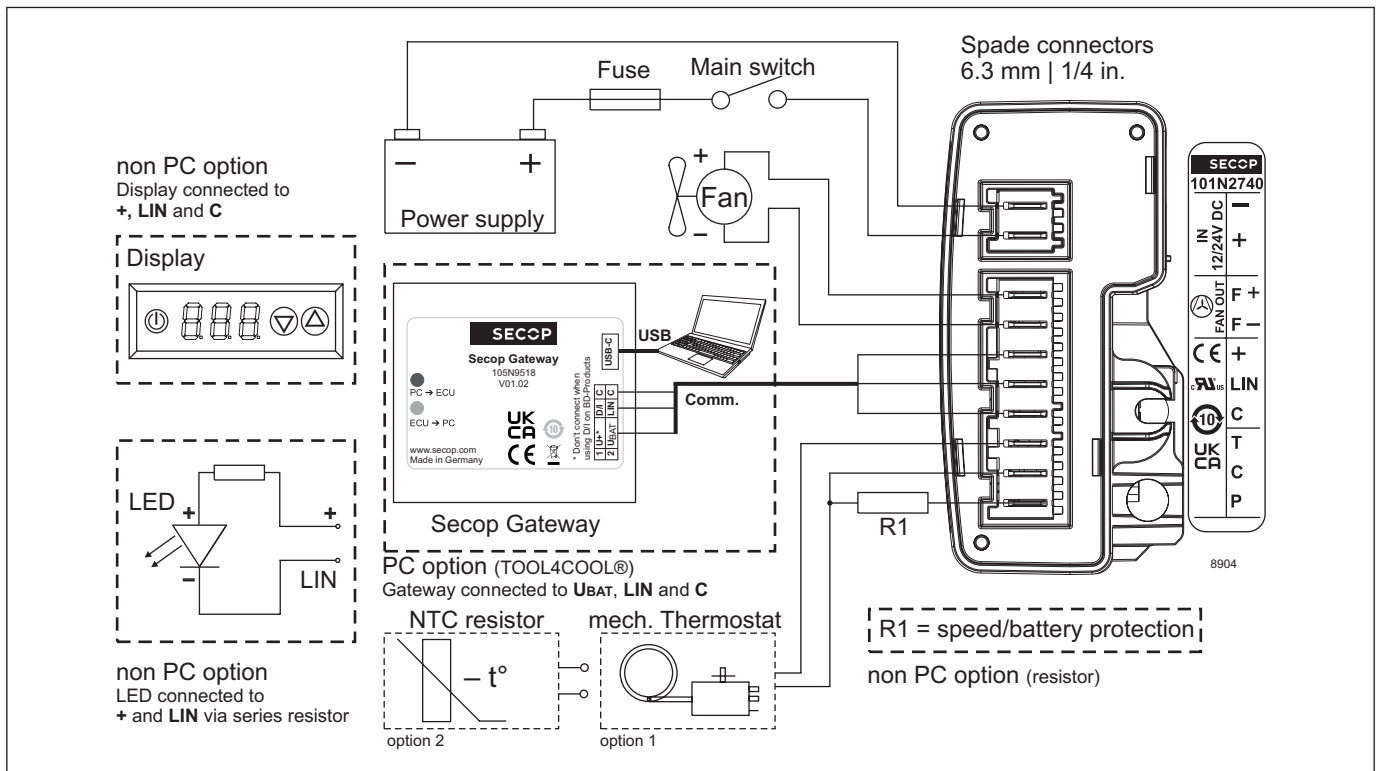

Secop accepts no responsibility for possible errors in catalogs, brochures, and other printed material. Secop reserves the right to alter its products without notice. This also applies to products already on order provided that such alterations can be made without substantial changes being necessary to specifications already agreed. All trademarks in this material are the property of the respective companies. Secop and the Secop logotype are trademarks of Secop GmbH. All rights reserved. www.secop.com

Brazing on Discharge Connector (BDN45F, BDN50K, BDN45F-A, and MB3CKV)

The BDN45F, BDN50K, and MB3CKV compressors use a special discharge connector element (see figure 2) that is directly connected to the discharge tube to optimize energy consumption. This element is made from plastic and sensitive to high heat exposure.

When brazing a tube into the discharge connector (see figure 1) please ensure that the area with the discharge connector element never exceeds 150°C / 302°F. Don't heat up the bottom of the connector directly.

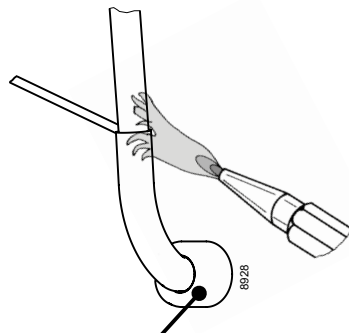

! max. 150°C/302°F !
at socket
 brazing solder: silver with flux

Use a fork burner (see figure 3) and/or a damp cloth, if necessary. A protective plate can also serve to protect the discharge connector element from direct heat from a flame. Do not braze longer than 10 seconds and wait for 5 minutes for the next soldering attempt.

Further information:

Product Bulletin – Brazing Technique for Compressor Connectors (DES.N.600.A1.02)



Fig.1 BDN45F discharge connector

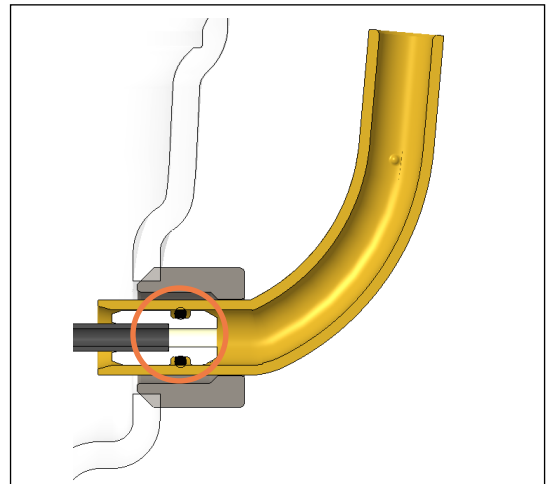

Fig.2 Discharge connector element

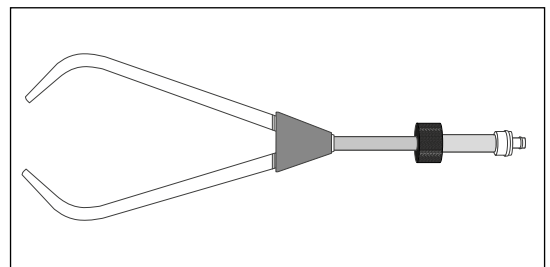

Fig.3 Fork burner



Instructions for Electronic Units
are available for download on
www.secop.com



BD Compressors



Service/Repair

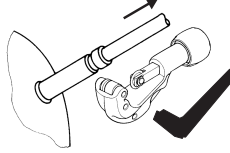

BD Nano



**! max. 150°C/302°F !
at socket**
brazing solder: silver with flux

Do not heat up the bottom of the discharge connector directly.
Do not braze longer than 10 seconds and wait for 5 minutes for the next soldering attempt (Product Bulletin DES.N.101.M1).

BD Micro



BD P-Housing



BD T-Housing



Secop accepts no responsibility for possible errors in catalogs, brochures, and other printed material. Secop reserves the right to alter its products without notice. This also applies to products already on order provided that such alterations can be made without subsequential changes being necessary to specifications already agreed. All trademarks in this material are the property of the respective companies. Secop and the Secop logotype are trademarks of Secop GmbH. All rights reserved. www.secop.com