

Single Pack SC12FT 220-240V 50/60Hz CSIR

Single pack code number: **195B4057**

Position	Title	Code	Amount
1	Compressor SC12FT	104G8205	1
2	Starting relay	117U6003	1
3	Starting capacitor (80 μ F 220V, 6.3mm)	117U5017	1
4	Cord relief	103N1004	1
5	Cover	103N2009	1
6	Bolt joint for one compressor M6 \varnothing 16mm	118-1917	1

Secop GmbH • Lise-Meitner-Straße 29 • 24941 Flensburg, Germany • Tel: +49 461 4941 0 • www.secop.com

Secop accepts no responsibility for possible errors in catalogs, brochures, and other printed material. Secop reserves the right to alter its products without notice. This also applies to products already on order provided that such alterations can be made without subsequent changes being necessary to specifications already agreed. All trademarks in this material are the property of the respective companies. Secop and the Secop logotype are trademarks of Secop GmbH. All rights reserved.

Model

Designation	SC12FT	220-240V/50Hz 1~ 220-240V/60Hz 1~	Sales code:	104G8205
-------------	---------------	-----------------------------------	-------------	-----------------

Compressor design

Oil type	Polyolester	Refrigerant(s)	R134a
Oil viscosity	22cST	Displacement	12,87cm ³ / 0,79cu.in
Oil quantity	550cm ³ / 18,6fl.oz	Compressors on pallet	80
Refr. charge - tech. limit	1300g / 45,9oz		
Free gas volume comp.	1410cm ³ / 47,7fl.oz		
Weight	12,7kg / 28lbs		
Motor protection	1# internal		
Winding resistance main	6,9Ω (at 25°C)		
Winding resistance aux	11Ω (at 25°C)		
Max. winding temp.	125°C / 257°F		
Max. discharge temp.	135°C / 275°F		



General - Configurations with SC12FT

	Conf. 1	Conf. 2	Conf. 3	Conf. 4
Motorconfiguration	CSIR	CSIR	RSIR	RSIR
Power supply (nominal)	220-240V/50Hz	208-230V/60Hz	220-240V/50Hz	208-230V/60Hz
Number of phases	1	1	1	1
Voltage range	187-254V	198-254V	187-254V	198-254V
Approvals	CCC, VDE	CCC, VDE	CCC, VDE	CCC, VDE
Starting torque	HST	HST	LST	LST
Note	- / -			

Applications with SC12FT

	Conf. 1	Conf. 2	Conf. 3	Conf. 4
Refrigerant	R134a	R134a	R134a	R134a
Application	LBP	LBP	LBP	LBP
System cooling	fan 1,5m/s	fan 1,5m/s	fan 1,5m/s	fan 1,5m/s
Hot gas defrost	OK	OK	OK	OK
Long interval pull down	OK	OK	OK	OK

Electrical data - Configurations with SC12FT

	Conf. 1	Conf. 2	Conf. 3	Conf. 4
Starting device type	relay	relay	PTC	PTC
Run capacitor	-/ -	-/ -	-/ -	-/ -
Start capacitor	80μF	80μF	-/ -	-/ -
LRA (locked rotor amps / 4s)	23,4A	23,4A		
RLA (rated load amps / 1s)	4,3A	4,3A	-/ -A	-/ -A
Cut in current	23,4A	23,4A		

Model

Designation

SC12FT

220-240V/50Hz 1~ 220-240V/60Hz 1~

Sales code:

104G8205

Compressor dimensions

Housing	A Height	209mm / 8,23in
	B Height	203mm / 7,99in
	C Length shell	218mm / 8,58in
	D Length w. cover	255mm / 10,04in
	E Width	151mm / 5,94in

Connectors	Suction X	Discharge Y	Process Z
Diameter [mm]	øi 8,11-8,29	øi 6,11-6,29	øi 6,11-6,29
(i:inside, o:outside) [in]	øi 0,32-0,33	øi 0,24-0,25	øi 0,24-0,25
Material	copper	copper	copper
Horizontal angle ±2°	37°	37°	143°
Vertical angle ±2°	30°	0°	150°
Position l/h/w [mm]	107/183/55	115/100/63	-107/183/55
[in]	4,2/7,2/2,2	4,5/3,9/2,5	-4,2/7,2/2,2
Straight tube l. [mm]	12	12	12
[in]	0,5	0,5	0,5



Compressor fixation



Bolt joint



Snap-on



Mounting accessories

Mounting accessories	one comp.	multi pack
Bolt joint M6 ø16mm	118-1917	118-1918
Bolt joint ø1/4" ø16mm	118-1946	
Bolt joint ø1/4" ø19mm	118-1949	
Snap-on ø7,3 ø16mm	118-1947	118-1919

Application notes

Provision for PE Grounding is located at the PE Stamp on the compressor

Model

Designation	SC12FT	220-240V/50Hz	Conf. 1	Sales code:	104G8205
-------------	---------------	----------------------	----------------	-------------	-----------------

Configuration

Motorconfiguration	CSIR
Power supply (nominal)	220-240V/50Hz 1~
Refrigerant	R134a
Application	LBP
Voltage range	187-254V
Starting torque	HST
Approvals	CCC VDE

Electrical accessories / wiring diagram

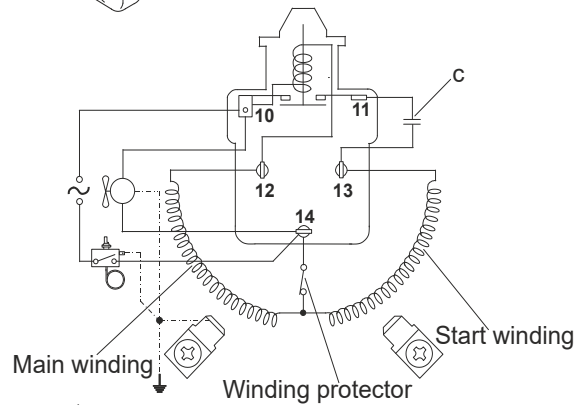
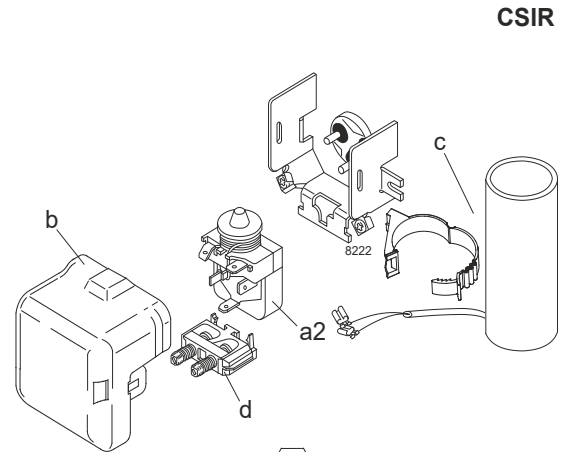

Ambient/ machine room temperatures minimum /maximum

Ambient temperature range:	10 - 43°C / 50 - 110°F
Machine room temperature range:	10 - 48°C / 50 - 119°F
Compressor cooling:	fan 1,5m/s

Operation Limits

F1 at 43°C ambient temperature possible at 220V nominal (187-242V)

Operation pressure range

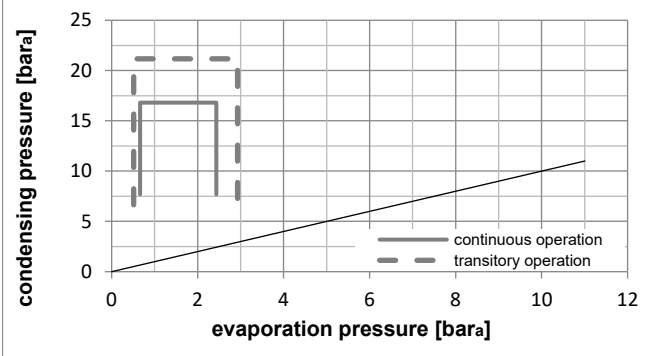
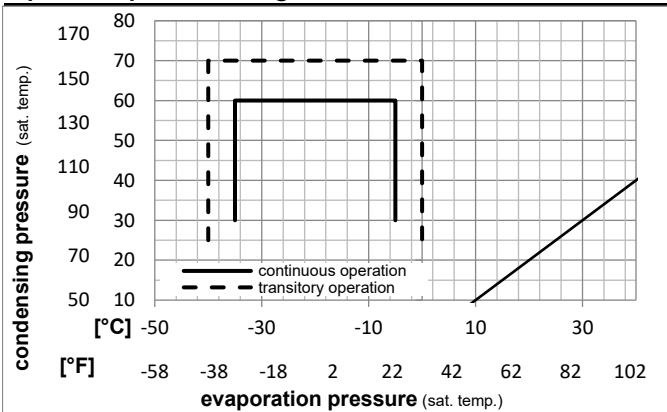

Components

a2	assy. relay	117U6003
c	start capacitor (80μF)	117U5017
d	cord relief	103N1004
b	plastic cover	103N2009

Model

Designation **SC12FT** **220-240V/50Hz** Conf. 1 Sales code: **104G8205**

Optimization + standard conditions

R134a, 220V/50Hz, CSIR, fan 1,5m/s, CCC, VDE

	Evaporating pressure (saturation temperature)				Condensing pressure (saturation temperature)			Return gas temp.	Liquid temp.	Cooling capacity	COP	EER	Power consumption			Ref. mass flow
	pe	pc	RGT	Tliq	[W]	[Btu/h]	[kcal/h]						P1	I	m	
[°C]																
[°F]																
	-23	54	32	32	320,4	1094	275,8	1,15	3,94	0,99	277,9	2,08	6,22	ASHRAE LBP		
	-10	130	90	90												
	-25	55	32	55	233,0	796	200,5	0,88	3,00	0,76	265,0	2,04	5,57	cecomaf LBP		
	-13	131	90	131												
	-35	40	20	40	155,2	530	133,6	0,79	2,68	0,68	197,6	1,87	3,41	EN12900 LBP		
	-31	104	68	104												
	-23	49	4,4	49	266,9	911	229,7	0,96	3,29	0,83	277,2	2,08	7,05	ARI540 LBP		
	-10	120	40	120												
	-23	41	32	32	362,5	1238	312,0	1,35	4,60	1,16	268,9	2,07	7,04	AHAM LBP		
	-10	105	90	90												
	-35	45	32	45	142,4	486	122,6	0,73	2,48	0,62	196,4	1,86	3,07	opt		
	-31	113	90	113												

Performance tables

R134a, 220V/50Hz, CSIR, fan 1,5m/s, CCC, VDE

	pe		Cooling capacity			COP	EER	P1	I	m	
	[°C]	[°F]	[W]	[Btu/h]	[kcal/h]	[W/W]	[Btu/Wh]	[kcal/Wh]	[W]	[A]	[kg/h]
[°C / °F]	-35	-31	142,4	486	122,6	0,73	2,48	0,62	196,4	1,86	3,07
cond. pressure	-30	-22	205,6	702	176,9	0,89	3,05	0,77	230,5	1,95	4,44
pc= 45/113	-25	-13	283,3	968	243,8	1,08	3,67	0,93	263,3	2,04	6,14
return gas temp.	-23	-10	313,5	1071	269,8	1,14	3,90	0,98	274,4	2,08	6,80
RGT= 32/90	-20	-4	378,1	1291	325,4	1,28	4,36	1,10	296,2	2,15	8,21
liquid temp	-15	5	492,1	1681	423,5	1,49	5,09	1,28	330,3	2,27	10,73
Tliq= 45/113	-5	23	787,4	2689	677,7	1,93	6,60	1,66	407,4	2,55	17,32
[°C / °F]	-35	-31	102,5	350	88,3	0,56	1,91	0,48	183,7	1,84	2,44
cond. pressure	-30	-22	163,4	558	140,6	0,72	2,47	0,62	225,6	1,93	3,90
pc= 55/131	-25	-13	233,0	796	200,5	0,88	3,00	0,76	265,0	2,04	5,57
return gas temp	-23	-10	259,0	885	222,9	0,93	3,18	0,80	278,0	2,08	6,20
RGT= 32/90	-20	-4	313,6	1071	269,9	1,03	3,53	0,89	303,0	2,17	7,52
liquid temp	-15	5	407,6	1392	350,8	1,20	4,08	1,03	341,1	2,30	9,81
Tliq= 55/131	-5	23	644,9	2203	555,0	1,53	5,22	1,32	422,0	2,61	15,68

Model

Designation	SC12FT	208-230V/60Hz	Conf. 2	Sales code:	104G8205
-------------	---------------	----------------------	----------------	-------------	-----------------

Configuration

Motorconfiguration	CSIR
Power supply (nominal)	208-230V/60Hz 1~
Refrigerant	R134a
Application	LBP
Voltage range	198-254V
Starting torque	HST
Approvals	CCC VDE

Electrical accessories / wiring diagram

CSIR

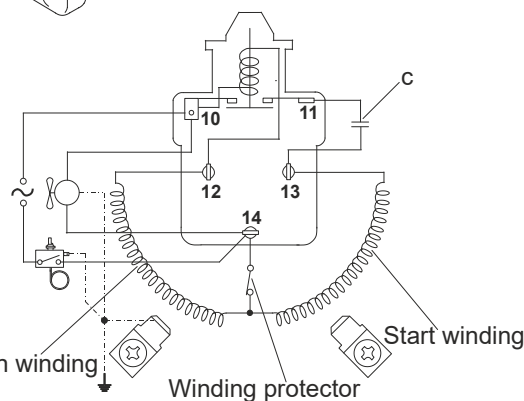
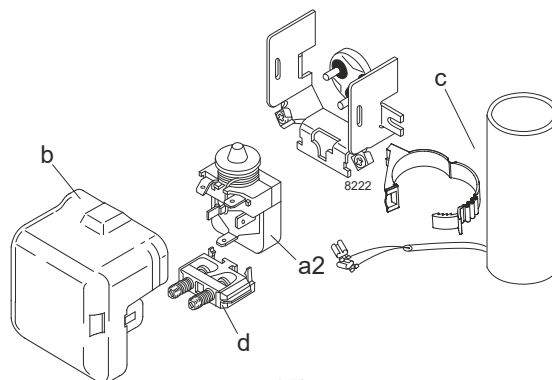

Ambient/ machine room temperatures minimum /maximum

Ambient temperature range: 10 - 43°C / 50 - 110°F

Machine room temperature range: 10 - 48°C / 50 - 119°F

Compressor cooling: fan 1,5m/s

Operation Limits

F1 at 43°C ambient temperature possible at 220V nominal (187-242V)

Operation pressure range

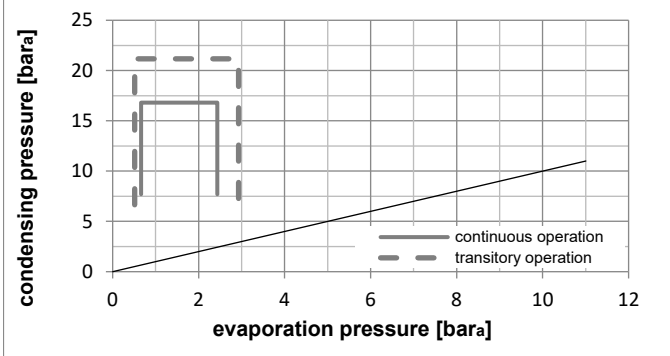
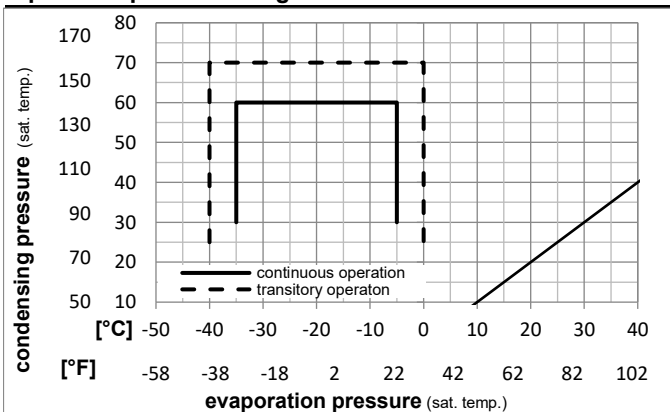

Components

a2	assy. relay	117U6003
c	start capacitor (80µF)	117U5017
d	cord relief	103N1004
b	plastic cover	103N2009

Model

Designation	SC12FT	208-230V/60Hz	Conf. 2	Sales code:	104G8205
-------------	---------------	----------------------	----------------	-------------	-----------------

Optimization + standard conditions

R134a, 220V/60Hz, CSIR, fan 1,5m/s, CCC, VDE

	Evaporating pressure (saturation temperature)				Cooling capacity			COP	EER	P1	Power consumption			ASHRAE LBP
	pe	pc	RGT	Tliq	[W]	[Btu/h]	[kcal/h]				l	Ref. mass flow		
	[°C]	[°F]	[°C]	[°F]	[W]	[Btu/h]	[kcal/h]	[W/W]	[Btu/Wh]	[kcal/Wh]	[W]	[A]	[kg/h]	
	-23	54	32	32	373,8	1277	321,7	1,18	4,04	1,02	315,9	1,98	7,26	ASHRAE LBP
	-10	130	90	90										
	-25	55	32	55	272,0	929	234,1	0,91	3,12	0,79	298,0	1,92	6,50	cecomaf LBP
	-13	131	90	131										
	-35	40	20	40	192,1	656	165,3	0,88	3,02	0,76	217,5	1,66	4,21	EN12900 LBP
	-31	104	68	104										
	-23	49	4,4	49	313,8	1072	270,1	0,99	3,37	0,85	317,6	1,98	8,29	ARI540 LBP
	-10	120	40	120										
	-23	41	32	32	437,8	1495	376,8	1,38	4,70	1,18	318,2	1,97	8,50	AHAM LBP
	-10	105	90	90										
	-35	45	32	45	172,6	589	148,5	0,82	2,81	0,71	210,1	1,64	3,72	opt
	-31	113	90	113										

Performance tables

R134a, 220V/60Hz, CSIR, fan 1,5m/s, CCC, VDE

	pe		Cooling capacity			COP	EER	P1	l	m	
	[°C]	[°F]	[W]	[Btu/h]	[kcal/h]						
[°C / °F]	-35	-31	172,6	589	148,5	0,82	2,81	0,71	210,1	1,64	3,72
cond. pressure	-30	-22	246,3	841	212,0	0,96	3,28	0,83	256,2	1,78	5,32
pc= 45/113	-25	-13	337,4	1152	290,4	1,11	3,81	0,96	302,7	1,93	7,31
return gas temp.	-23	-10	372,8	1273	320,8	1,17	4,00	1,01	318,5	1,98	8,08
RGT= 32/90	-20	-4	448,5	1532	386,0	1,28	4,39	1,11	349,3	2,08	9,74
liquid temp	-15	5	582,4	1989	501,2	1,47	5,02	1,27	395,8	2,25	12,69
Tliq= 45/113	-5	23	929,0	3173	799,5	1,90	6,51	1,64	487,7	2,61	20,43
[°C / °F]	-35	-31	124,5	425	107,2	0,64	2,20	0,55	193,3	1,58	2,96
cond. pressure	-30	-22	192,4	657	165,6	0,78	2,68	0,68	245,3	1,75	4,59
pc= 55/131	-25	-13	272,0	929	234,1	0,91	3,12	0,79	298,0	1,92	6,50
return gas temp	-23	-10	302,2	1032	260,1	0,96	3,27	0,82	316,0	1,98	7,23
RGT= 32/90	-20	-4	366,0	1250	315,0	1,04	3,56	0,90	351,2	2,10	8,78
liquid temp	-15	5	477,0	1629	410,5	1,18	4,03	1,01	404,6	2,30	11,48
Tliq= 55/131	-5	23	761,2	2599	655,1	1,49	5,08	1,28	511,3	2,71	18,50

Model

Designation	SC12FT	220-240V/50Hz	Conf. 3	Sales code:	104G8205
-------------	---------------	----------------------	----------------	-------------	-----------------

Configuration

Motorconfiguration	RSIR
Power supply (nominal)	220-240V/50Hz 1~
Refrigerant	R134a
Application	LBP
Voltage range	187-254V
Starting torque	LST
Approvals	CCC VDE

Electrical accessories / wiring diagram

RSIR

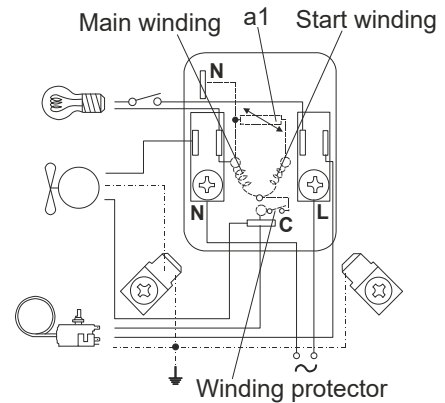
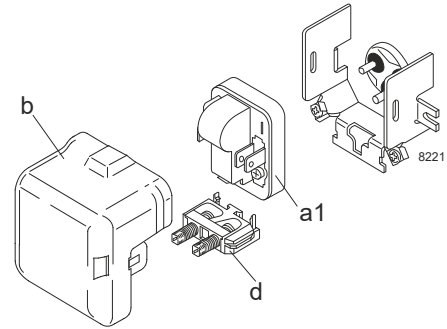

Ambient/ machine room temperatures minimum /maximum

Ambient temperature range:	10 - 43°C / 50 - 110°F
Machine room temperature range:	10 - 48°C / 50 - 119°F
Compressor cooling:	fan 1,5m/s

Operation Limits

F1 at 43°C ambient temperature possible at 220V nominal (187-242V)

Operation pressure range

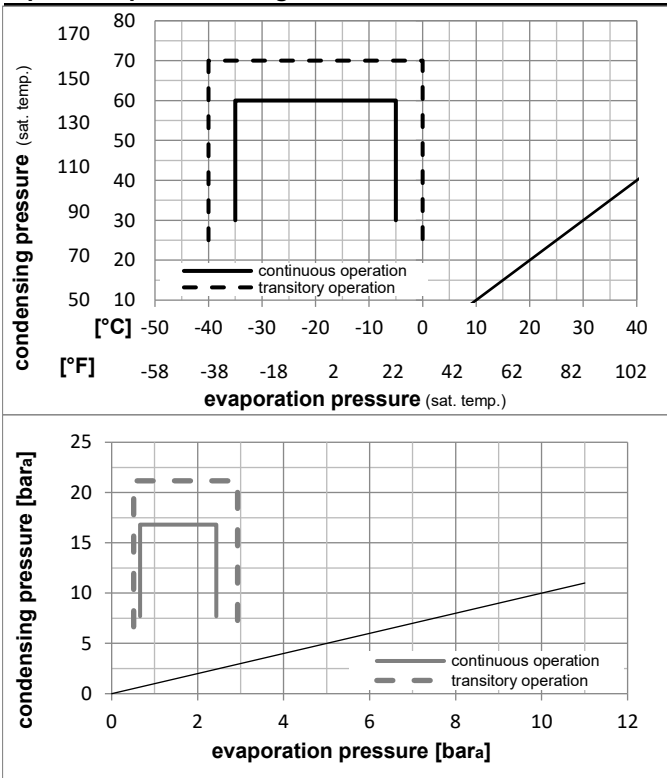

Components

a1	PTC starter (220V, 25Ohm, 6.3mm)	103N0011
d	cord relief	103N1004
b	plastic cover	103N2009

Model

Designation	SC12FT	220-240V/50Hz	Conf. 3	Sales code:	104G8205
-------------	---------------	----------------------	----------------	-------------	-----------------

Optimization + standard conditions

R134a, 220V/50Hz, RSIR, fan 1,5m/s, CCC, VDE

	Evaporating pressure (saturation temperature)				Cooling capacity			COP	EER	P1	Power consumption			ASHRAE LBP
	pe	pc	RGT	Tliq	[W]	[Btu/h]	[kcal/h]				Current consumption	Ref. mass flow		
	[°C]	[°F]	[°C]	[°F]	[W]	[Btu/h]	[kcal/h]	[W/W]	[Btu/Wh]	[kcal/Wh]	[W]	[A]	[kg/h]	
	-23	54	32	32	320,4	1094	275,8	1,15	3,94	0,99	277,9	2,08	6,22	ASHRAE LBP
	-10	130	90	90										
	-25	55	32	55	233,0	796	200,5	0,88	3,00	0,76	265,0	2,04	5,57	cecomaf LBP
	-13	131	90	131										
	-35	40	20	40	155,2	530	133,6	0,79	2,68	0,68	197,6	1,87	3,41	EN12900 LBP
	-31	104	68	104										
	-23	49	4,4	49	266,9	911	229,7	0,96	3,29	0,83	277,2	2,08	7,05	ARI540 LBP
	-10	120	40	120										
	-23	41	32	32	362,5	1238	312,0	1,35	4,60	1,16	268,9	2,07	7,04	AHAM LBP
	-10	105	90	90										
	-35	45	32	45	142,4	486	122,6	0,73	2,48	0,62	196,4	1,86	3,07	opt
	-31	113	90	113										

Performance tables

R134a, 220V/50Hz, RSIR, fan 1,5m/s, CCC, VDE

	pe		Cooling capacity			COP	EER	P1	I	m	
	[°C]	[°F]	[W]	[Btu/h]	[kcal/h]						
[°C / °F]	-35	-31	142,4	486	122,6	0,73	2,48	0,62	196,4	1,86	3,07
cond. pressure	-30	-22	205,6	702	176,9	0,89	3,05	0,77	230,5	1,95	4,44
pc= 45/113	-25	-13	283,3	968	243,8	1,08	3,67	0,93	263,3	2,04	6,14
return gas temp.	-23	-10	313,5	1071	269,8	1,14	3,90	0,98	274,4	2,08	6,80
RGT= 32/90	-20	-4	378,1	1291	325,4	1,28	4,36	1,10	296,2	2,15	8,21
liquid temp	-15	5	492,1	1681	423,5	1,49	5,09	1,28	330,3	2,27	10,73
Tliq= 45/113	-5	23	787,4	2689	677,7	1,93	6,60	1,66	407,4	2,55	17,32
[°C / °F]	-35	-31	102,5	350	88,3	0,56	1,91	0,48	183,7	1,84	2,44
cond. pressure	-30	-22	163,4	558	140,6	0,72	2,47	0,62	225,6	1,93	3,90
pc= 55/131	-25	-13	233,0	796	200,5	0,88	3,00	0,76	265,0	2,04	5,57
return gas temp	-23	-10	259,0	885	222,9	0,93	3,18	0,80	278,0	2,08	6,20
RGT= 32/90	-20	-4	313,6	1071	269,9	1,03	3,53	0,89	303,0	2,17	7,52
liquid temp	-15	5	407,6	1392	350,8	1,20	4,08	1,03	341,1	2,30	9,81
Tliq= 55/131	-5	23	644,9	2203	555,0	1,53	5,22	1,32	422,0	2,61	15,68

Model

Designation	SC12FT	208-230V/60Hz	Conf. 4	Sales code:	104G8205
-------------	---------------	----------------------	----------------	-------------	-----------------

Configuration

Motorconfiguration	RSIR
Power supply (nominal)	208-230V/60Hz 1~
Refrigerant	R134a
Application	LBP
Voltage range	198-254V
Starting torque	LST
Approvals	CCC VDE

Electrical accessories / wiring diagram

RSIR

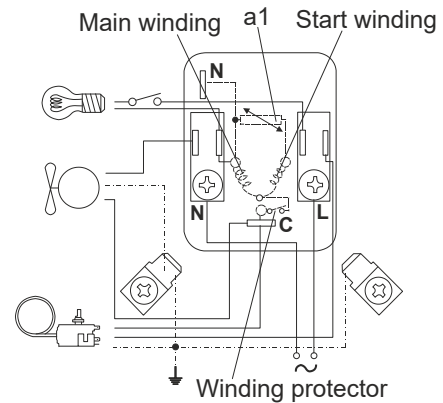
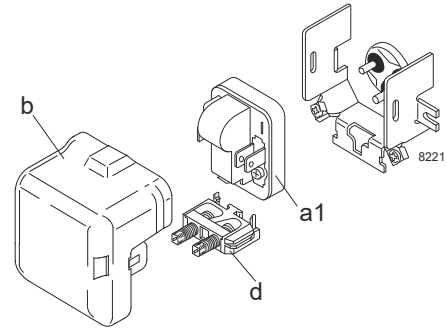

Ambient/ machine room temperatures minimum /maximum

Ambient temperature range:	10 - 43°C / 50 - 110°F
Machine room temperature range:	10 - 48°C / 50 - 119°F
Compressor cooling:	fan 1,5m/s

Operation Limits

F1 at 43°C ambient temperature possible at 220V nominal (187-242V)

Operation pressure range

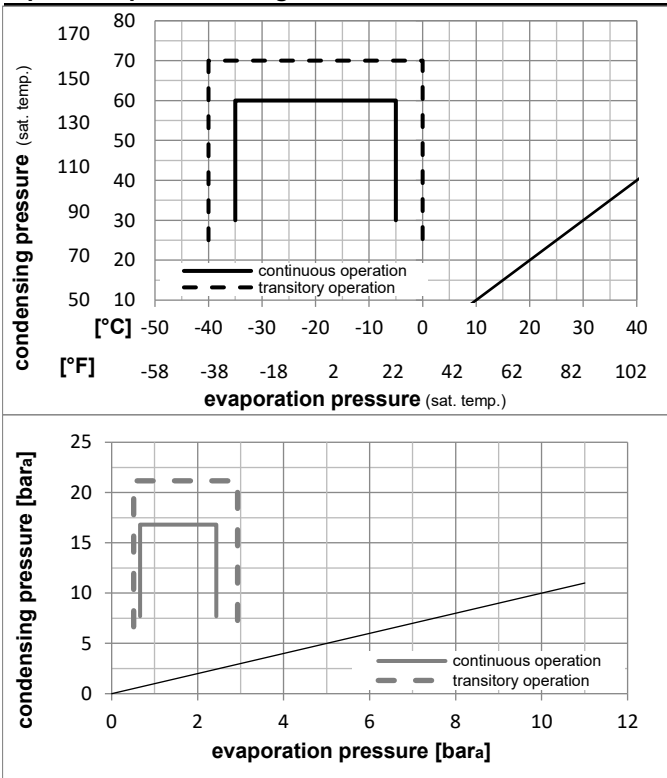

Components

a1	PTC starter (220V, 25Ohm, 6.3mm)	103N0011
d	cord relief	103N1004
b	plastic cover	103N2009

Model

Designation	SC12FT	208-230V/60Hz	Conf. 4	Sales code:	104G8205
-------------	---------------	----------------------	----------------	-------------	-----------------

Optimization + standard conditions

R134a, 220V/60Hz, RSIR, fan 1,5m/s, CCC, VDE

	Evaporating pressure (saturation temperature)				Cooling capacity			COP	EER	P1	Power consumption			ASHRAE LBP
	pe	pc	RGT	Tliq	[W]	[Btu/h]	[kcal/h]				l	Ref. mass flow		
	[°C]	[°F]	[°C]	[°F]	[W]	[Btu/h]	[kcal/h]	[W/W]	[Btu/Wh]	[kcal/Wh]	[W]	[A]	[kg/h]	
	-23	54	32	32	373,8	1277	321,7	1,18	4,04	1,02	315,9	1,98	7,26	ASHRAE LBP
	-10	130	90	90										
	-25	55	32	55	272,0	929	234,1	0,91	3,12	0,79	298,0	1,92	6,50	cecomaf LBP
	-13	131	90	131										
	-35	40	20	40	192,1	656	165,3	0,88	3,02	0,76	217,5	1,66	4,21	EN12900 LBP
	-31	104	68	104										
	-23	49	4,4	49	313,8	1072	270,1	0,99	3,37	0,85	317,6	1,98	8,29	ARI540 LBP
	-10	120	40	120										
	-23	41	32	32	437,8	1495	376,8	1,38	4,70	1,18	318,2	1,97	8,50	AHAM LBP
	-10	105	90	90										
	-35	45	32	45	172,6	589	148,5	0,82	2,81	0,71	210,1	1,64	3,72	opt
	-31	113	90	113										

Performance tables

R134a, 220V/60Hz, RSIR, fan 1,5m/s, CCC, VDE

	pe		Cooling capacity			COP	EER	P1	l	m	
	[°C]	[°F]	[W]	[Btu/h]	[kcal/h]						
[°C / °F]	-35	-31	172,6	589	148,5	0,82	2,81	0,71	210,1	1,64	3,72
cond. pressure	-30	-22	246,3	841	212,0	0,96	3,28	0,83	256,2	1,78	5,32
pc= 45/113	-25	-13	337,4	1152	290,4	1,11	3,81	0,96	302,7	1,93	7,31
return gas temp.	-23	-10	372,8	1273	320,8	1,17	4,00	1,01	318,5	1,98	8,08
RGT= 32/90	-20	-4	448,5	1532	386,0	1,28	4,39	1,11	349,3	2,08	9,74
liquid temp	-15	5	582,4	1989	501,2	1,47	5,02	1,27	395,8	2,25	12,69
Tliq= 45/113	-5	23	929,0	3173	799,5	1,90	6,51	1,64	487,7	2,61	20,43
[°C / °F]	-35	-31	124,5	425	107,2	0,64	2,20	0,55	193,3	1,58	2,96
cond. pressure	-30	-22	192,4	657	165,6	0,78	2,68	0,68	245,3	1,75	4,59
pc= 55/131	-25	-13	272,0	929	234,1	0,91	3,12	0,79	298,0	1,92	6,50
return gas temp	-23	-10	302,2	1032	260,1	0,96	3,27	0,82	316,0	1,98	7,23
RGT= 32/90	-20	-4	366,0	1250	315,0	1,04	3,56	0,90	351,2	2,10	8,78
liquid temp	-15	5	477,0	1629	410,5	1,18	4,03	1,01	404,6	2,30	11,48
Tliq= 55/131	-5	23	761,2	2599	655,1	1,49	5,08	1,28	511,3	2,71	18,50



SC Compressors





SC Compressors

Service/Repair – R290



8545



Secop accepts no responsibility for possible errors in catalogs, brochures, and other printed material. Secop reserves the right to alter its products without notice. This also applies to products already on order provided that such alterations can be made without subsequent changes being necessary to specifications already agreed. All trademarks in this material are the property of the respective companies. Secop and the Secop logotype are trademarks of Secop GmbH. All rights reserved. www.secop.com