

Single Pack NL8.4CLX 220-240V 50Hz CSIR

Single pack code number: **195B4083**

Position	Title	Code	Amount
1	Compressor NL8.4CLX	105F3800	1
2	Starting relay	117U6003	1
3	Starting capacitor (80 μ F 220V, 6.3mm)	117U5015	1
4	Cord relief	103N1010	1
5	Cover	103N2010	1
6	Bolt joint for one compressor M6 \varnothing 16mm	118-1917	1

Secop GmbH • Lise-Meitner-Straße 29 • 24941 Flensburg, Germany • Tel: +49 461 4941 0 • www.secop.com

Secop accepts no responsibility for possible errors in catalogs, brochures, and other printed material. Secop reserves the right to alter its products without notice. This also applies to products already on order provided that such alterations can be made without subsequent changes being necessary to specifications already agreed. All trademarks in this material are the property of the respective companies. Secop and the Secop logotype are trademarks of Secop GmbH. All rights reserved.

Model

Designation	NL8.4CLX	220-240V/50Hz 1~	Sales code:	105F3800
-------------	-----------------	------------------	-------------	-----------------

Compressor design

Oil type	Polyolester	Refrigerant(s)	R404A, R507, R452A
Oil viscosity	32cST	Displacement	8,35cm ³ / 0,51cu.in
Oil quantity	300cm ³ / 10,1fl.oz	Compressors on pallet	80
Refr. charge - tech. limit	400g / 14,1oz		
Free gas volume comp.	2310cm ³ / 78,1fl.oz		
Weight	10,4kg / 22,9lbs		
Motor protection	1# internal		
Winding resistance main	6,1Ω (at 25°C)		
Winding resistance aux	16Ω (at 25°C)		
Max. winding temp.	125°C / 257°F		
Max. discharge temp.	130°C / 266°F		



General - Configurations with NL8.4CLX

	Conf. 1	Conf. 2	Conf. 3	Conf. 4
Motorconfiguration	RSIR	CSIR	RSIR	CSIR
Power supply (nominal)	220-240V/50Hz	220-240V/50Hz	220-240V/50Hz	220-240V/50Hz
Number of phases	1	1	1	1
Voltage range	198-254V	198-254V	198-254V	198-254V
Approvals	VDE, CCC, EAC	VDE, CCC, EAC	VDE, EAC	VDE, EAC
Starting torque	LST	HST	LST	HST
Note	- / -			

Applications with NL8.4CLX

	Conf. 1	Conf. 2	Conf. 3	Conf. 4
Refrigerant	R404A	R404A	R452A	R452A
Application	LBP	LBP	LBP	LBP
System cooling	fan 3m/s	fan 3m/s	fan 3m/s	fan 3m/s
Hot gas defrost	- / -	- / -	- / -	- / -
Long interval pull down	- / -	- / -	- / -	- / -

Electrical data - Configurations with NL8.4CLX

	Conf. 1	Conf. 2	Conf. 3	Conf. 4
Starting device type	PTC	relay	PTC	relay
Run capacitor	- / -	- / -	- / -	- / -
Start capacitor	- / -	80μF	- / -	80μF
LRA (locked rotor amps / 4s)	12,1A	13,7A	12,1A	13,7A
RLA (rated load amps / 1s)	2,5A	2,5A	2,5A	2,5A
Cut in current	15,6A	13,7A	15,6A	13,7A

Model

Designation

NL8.4CLX

220-240V/50Hz 1~

Sales code:

105F3800

Compressor dimensions

Housing	A Height	203mm / 7,99in
	B Height	197mm / 7,76in
	C Length shell	205mm / 8,07in
	D Length w. cover	254mm / 10in
	E Width	166mm / 6,54in

Connectors	Suction X	Discharge Y	Process Z
Diameter [mm]	øi 8,11-8,29	øi 6,11-6,29	øi 6,11-6,29
(i:inside, o:outside) [in]	øi 0,32-0,33	øi 0,24-0,25	øi 0,24-0,25
Material	copper	copper	copper
Horizontal angle ±2°	0°	0°	0°
Vertical angle ±2°	15°	35°	155°
Position l/h/w [mm]	126/76/78	133/103/54	-107/94/72
[in]	4,9/3/3,1	5,2/4/2,1	-4,2/3,7/2,8
Straight tube l. [mm]	12	12	12
[in]	0,5	0,5	0,5

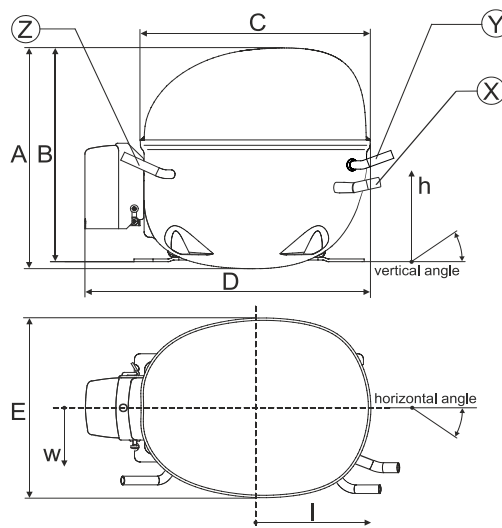

Compressor fixation

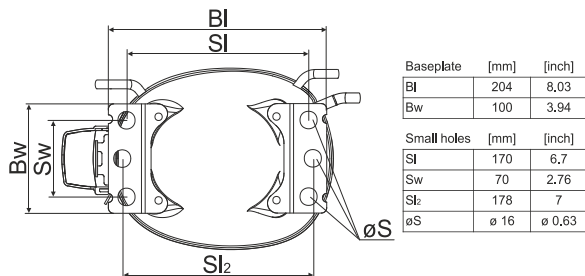

Bolt joint

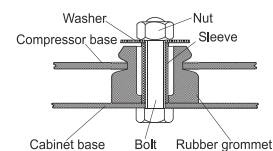

Snap-on

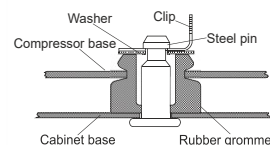

Mounting accessories	one comp.	multi pack
Bolt joint M6 ø16mm	118-1917	118-1918
Bolt joint ø1/4" ø16mm	118-1946	
Bolt joint ø1/4" ø19mm	118-1949	
Snap-on ø7,3 ø16mm	118-1947	118-1919

Application notes

Provision for PE Grounding is located at the PE Stamp on the compressor

Model

Designation	NL8.4CLX	220-240V/50Hz	Conf. 1	Sales code:	105F3800
-------------	-----------------	----------------------	----------------	-------------	-----------------

Configuration

Motorconfiguration	RSIR
Power supply (nominal)	220-240V/50Hz 1~
Refrigerant	R404A
Application	LBP
Voltage range	198-254V
Starting torque	LST
Approvals	VDE (2)
	(1): Made in China CCC (1),(2)
	(2): Made in Slovakia EAC (1),(2)

Electrical accessories / wiring diagram

RSIR

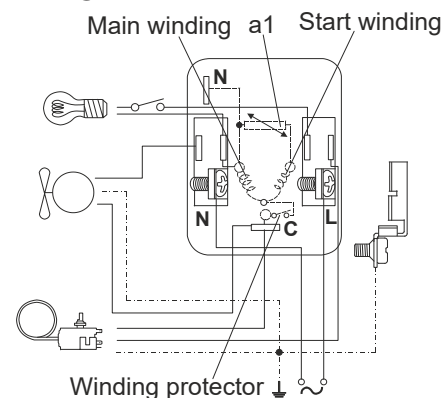
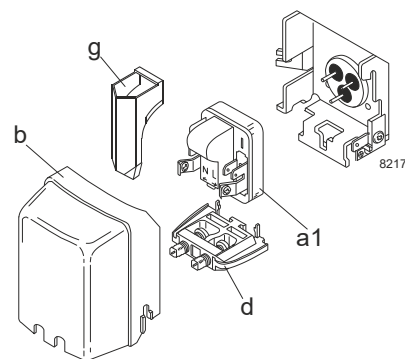

Ambient/ machine room temperatures minimum /maximum

Ambient temperature range:	10 - 38°C / 50 - 101°F
Machine room temperature range:	10 - 43°C / 50 - 110°F
Compressor cooling:	fan 3m/s

Operation Limits

Operation pressure range

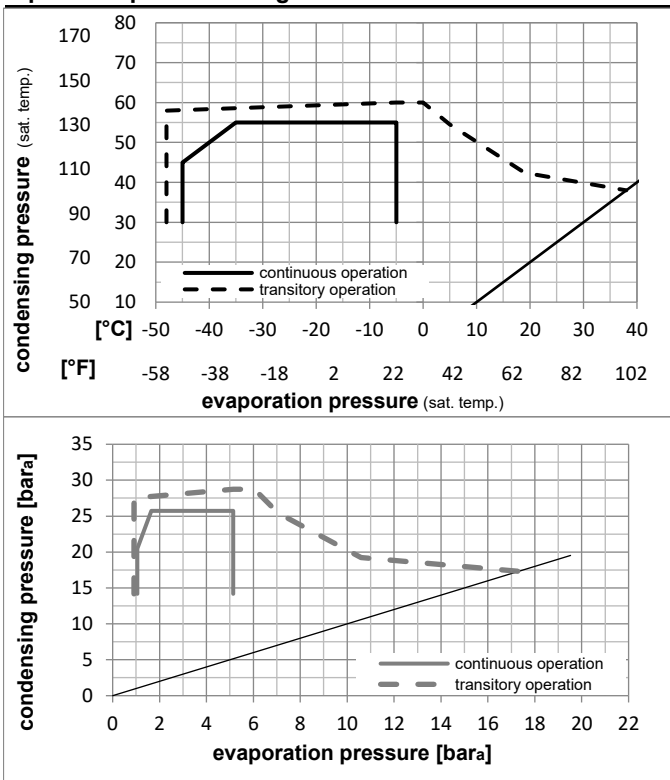

Components

a1	PTC starter (220V, 250hm, 4.8mm)	103N0018
b	plastic cover	103N2010
d	cord relief	103N1010
g	protection screen for PTC	103N0476

Alternative components

a1	PTC starter (220V, 250hm, 6.3mm)	103N0011
b	plastic cover	103N2011
d	cord relief	103N1010
g	protection screen for PTC	103N0476

Model

Designation **NL8.4CLX** **220-240V/50Hz** Conf. 1 Sales code: **105F3800**

Optimization + standard conditions

R404A, 220V/50Hz, RSIR, fan 3m/s, VDE, CCC, EAC

		Evaporating pressure (saturation temperature)				Condensing pressure (saturation temperature)			Return gas temp.			Liquid temp.			Cooling capacity			COP	EER	Power consumption			
		pe	pc	RGT	Tliq	[W]	[Btu/h]	[kcal/h]	[W/W]	[Btu/Wh]	[kcal/Wh]	P1	I	Ref. mass flow									
[°C]	[°F]	[°C]	[°F]	[°C]	[°F]							[W]	[A]	[kg/h]									
-23	-10	54	130	32	90	421,4	1439	362,7	1,27	4,35	1,10	330,6	2,22	9,82									ASHRAE LBP
-25	-13	55	131	32	90	285,6	975	245,8	0,90	3,08	0,78	316,5	2,18	8,93									cecomaf LBP
-35	-31	40	104	20	68	228,8	781	196,9	0,98	3,36	0,85	232,5	1,87	6,22									EN12900 LBP
-23	-10	49	120	4,4	40	317,8	1085	273,5	0,98	3,34	0,84	325,2	2,19	11,25									ARI540 LBP
-23	-10	41	105	32	90	479,0	1636	412,2	1,56	5,34	1,35	306,2	2,11	11,16									AHAM LBP
-35	-31	45	113	32	90	216,4	739	186,3	0,91	3,10	0,78	238,6	1,89	5,79									opt

Performance tables

R404A, 220V/50Hz, RSIR, fan 3m/s, VDE, CCC, EAC

	pe		Cooling capacity			COP	EER	P1	I	m	
	[°C]	[°F]	[W]	[Btu/h]	[kcal/h]	[W/W]	[Btu/Wh]	[kcal/Wh]	[W]	[A]	[kg/h]
[°C / °F]	-45	-49	111,0	379	95,5	0,64	2,17	0,55	174,4	1,74	2,95
cond. pressure	-35	-31	216,4	739	186,3	0,91	3,10	0,78	238,6	1,89	5,79
pc= 45/113	-30	-22	286,5	979	246,6	1,06	3,61	0,91	271,3	1,99	7,69
return gas temp.	-25	-13	370,0	1264	318,4	1,21	4,13	1,04	305,6	2,11	9,98
RGT= 32/90	-20	-4	468,3	1599	403,0	1,37	4,67	1,18	342,6	2,25	12,70
liquid temp	-15	5	582,7	1990	501,5	1,52	5,20	1,31	383,1	2,40	15,92
Tliq= 45/113	-5	23	865,7	2957	745,0	1,81	6,18	1,56	478,6	2,76	24,07
[°C / °F]	-45	-49	75,9	259	65,4	0,48	1,63	0,41	158,8	1,71	2,33
cond. pressure	-35	-31	160,7	549	138,3	0,68	2,33	0,59	236,0	1,91	4,97
pc= 55/131	-30	-22	217,4	743	187,1	0,79	2,70	0,68	275,4	2,03	6,76
return gas temp	-25	-13	285,6	975	245,8	0,90	3,08	0,78	316,5	2,18	8,93
RGT= 32/90	-20	-4	366,6	1252	315,5	1,02	3,48	0,88	360,3	2,34	11,54
liquid temp	-15	5	461,8	1577	397,4	1,13	3,87	0,97	407,8	2,51	14,65
Tliq= 55/131	-5	23	700,2	2391	602,6	1,35	4,62	1,16	517,8	2,92	22,66

Model

Designation	NL8.4CLX	220-240V/50Hz	Conf. 2	Sales code:	105F3800
-------------	-----------------	----------------------	----------------	-------------	-----------------

Configuration

Motorconfiguration	CSIR
Power supply (nominal)	220-240V/50Hz 1~
Refrigerant	R404A
Application	LBP
Voltage range	198-254V
Starting torque	HST
Approvals	VDE (2)
(1): Made in China	CCC (1),(2)
(2): Made in Slovakia	EAC (1),(2)

Electrical accessories / wiring diagram

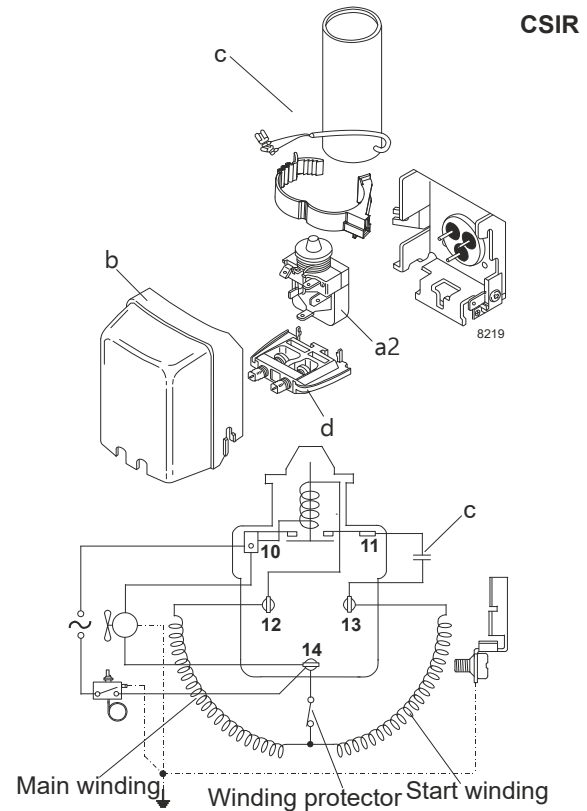

Ambient/ machine room temperatures minimum /maximum

Ambient temperature range:	10 - 38°C / 50 - 101°F
Machine room temperature range:	10 - 43°C / 50 - 110°F
Compressor cooling:	fan 3m/s

Operation Limits

Operation pressure range

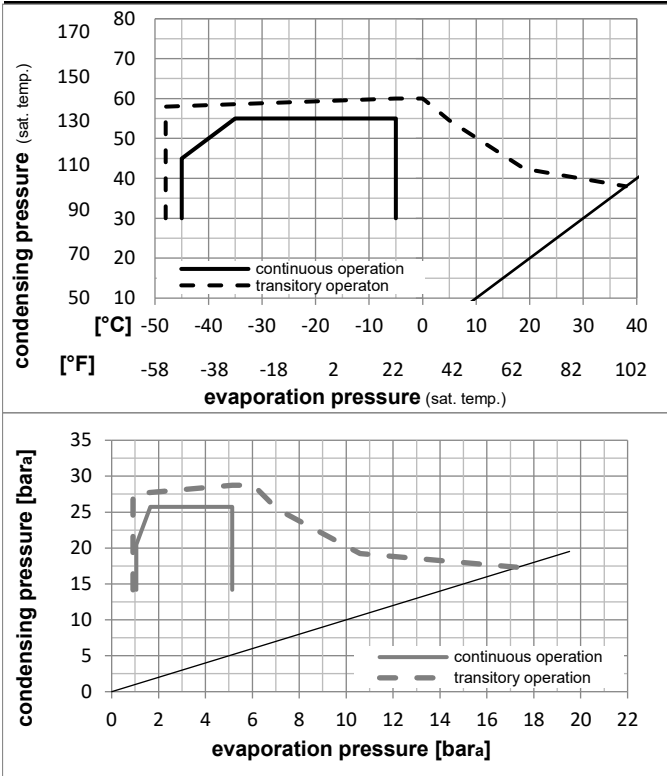

Components

a2	assy. relay	117U6003
c	start capacitor (80μF)	117U5015
b	plastic cover	103N2010
d	cord relief	103N1010

Alternative components

b	plastic cover	103N2011
---	---------------	----------

Model

Designation **NL8.4CLX** **220-240V/50Hz** Conf. 2 Sales code: **105F3800**

Optimization + standard conditions

R404A, 220V/50Hz, CSIR, fan 3m/s, VDE, CCC, EAC

		Evaporating pressure (saturation temperature)				Condensing pressure (saturation temperature)						Power consumption			
		Return gas temp.		Liquid temp.		Cooling capacity		COP	EER		P1	I	Ref. mass flow		
		pe	pc	RGT	Tliq	[W]	[Btu/h]	[kcal/h]	[W/W]	[Btu/Wh]	[kcal/Wh]	[W]	[A]	[kg/h]	
[°C]	-23	54	32	32	421,4	1439	362,7	1,27	4,35	1,10	330,6	2,22	9,82	ASHRAE LBP	
[°F]	-10	130	90	90											
[°C]	-25	55	32	55	285,6	975	245,8	0,90	3,08	0,78	316,5	2,18	8,93	cecomaf LBP	
[°F]	-13	131	90	131											
[°C]	-35	40	20	40	228,8	781	196,9	0,98	3,36	0,85	232,5	1,87	6,22	EN12900 LBP	
[°F]	-31	104	68	104											
[°C]	-23	49	4,4	49	317,8	1085	273,5	0,98	3,34	0,84	325,2	2,19	11,25	ARI540 LBP	
[°F]	-10	120	40	120											
[°C]	-23	41	32	32	479,0	1636	412,2	1,56	5,34	1,35	306,2	2,11	11,16	AHAM LBP	
[°F]	-10	105	90	90											
[°C]	-35	45	32	45	216,4	739	186,3	0,91	3,10	0,78	238,6	1,89	5,79	opt	
[°F]	-31	113	90	113											

Performance tables

R404A, 220V/50Hz, CSIR, fan 3m/s, VDE, CCC, EAC

	pe		Cooling capacity			COP	EER		P1	I	m
	[°C]	[°F]	[W]	[Btu/h]	[kcal/h]	[W/W]	[Btu/Wh]	[kcal/Wh]	[W]	[A]	[kg/h]
[°C / °F]	-45	-49	111,0	379	95,5	0,64	2,17	0,55	174,4	1,74	2,95
cond. pressure	-35	-31	216,4	739	186,3	0,91	3,10	0,78	238,6	1,89	5,79
pc= 45/113	-30	-22	286,5	979	246,6	1,06	3,61	0,91	271,3	1,99	7,69
return gas temp.	-25	-13	370,0	1264	318,4	1,21	4,13	1,04	305,6	2,11	9,98
RGT= 32/90	-20	-4	468,3	1599	403,0	1,37	4,67	1,18	342,6	2,25	12,70
liquid temp	-15	5	582,7	1990	501,5	1,52	5,20	1,31	383,1	2,40	15,92
Tliq= 45/113	-5	23	865,7	2957	745,0	1,81	6,18	1,56	478,6	2,76	24,07
[°C / °F]	-45	-49	75,9	259	65,4	0,48	1,63	0,41	158,8	1,71	2,33
cond. pressure	-35	-31	160,7	549	138,3	0,68	2,33	0,59	236,0	1,91	4,97
pc= 55/131	-30	-22	217,4	743	187,1	0,79	2,70	0,68	275,4	2,03	6,76
return gas temp	-25	-13	285,6	975	245,8	0,90	3,08	0,78	316,5	2,18	8,93
RGT= 32/90	-20	-4	366,6	1252	315,5	1,02	3,48	0,88	360,3	2,34	11,54
liquid temp	-15	5	461,8	1577	397,4	1,13	3,87	0,97	407,8	2,51	14,65
Tliq= 55/131	-5	23	700,2	2391	602,6	1,35	4,62	1,16	517,8	2,92	22,66

Model

Designation	NL8.4CLX	220-240V/50Hz	Conf. 3	Sales code:	105F3800
-------------	-----------------	----------------------	----------------	-------------	-----------------

Configuration

Motorconfiguration	RSIR
Power supply (nominal)	220-240V/50Hz 1~
Refrigerant	R452A
Application	LBP
Voltage range	198-254V
Starting torque	LST
Approvals	VDE (2)
(1): Made in China	EAC (1),(2)

Electrical accessories / wiring diagram

RSIR

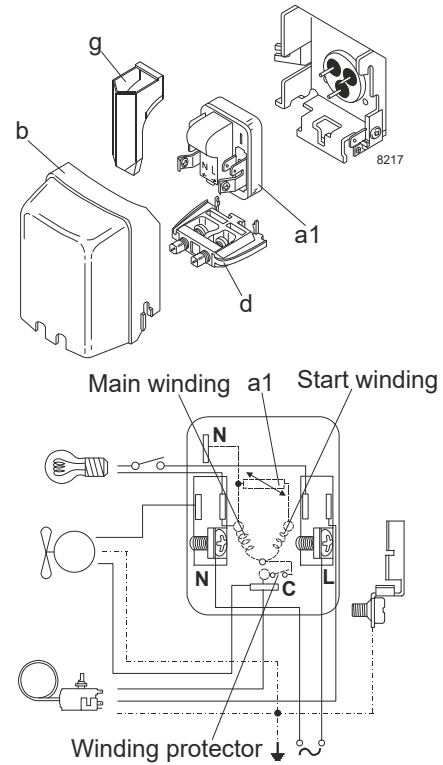

Ambient/ machine room temperatures minimum /maximum

Ambient temperature range:	10 - 38°C / 50 - 101°F
Machine room temperature range:	10 - 43°C / 50 - 110°F
Compressor cooling:	fan 3m/s

Operation Limits

Operation pressure range

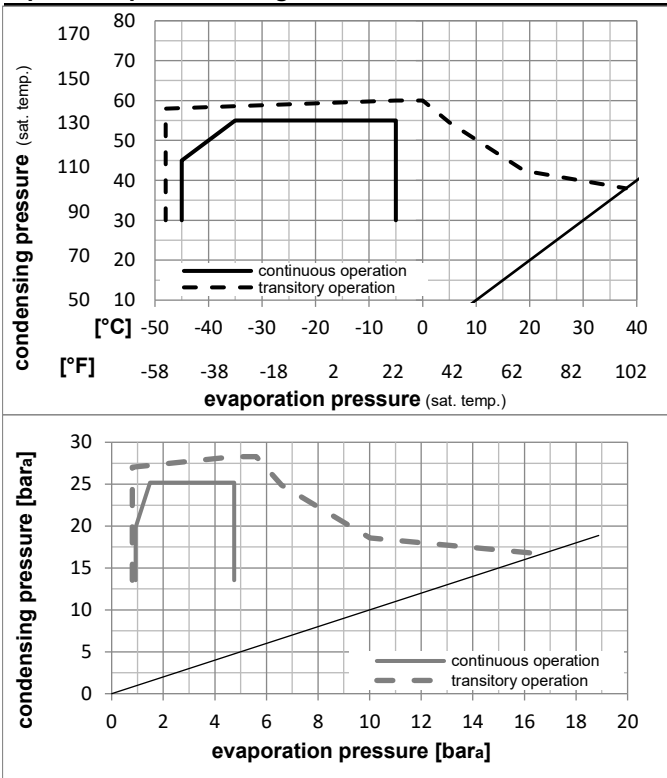

Components

a1	PTC starter (220V, 250hm, 4.8mm)	103N0018
b	plastic cover	103N2010
d	cord relief	103N1010
g	protection screen for PTC	103N0476

Alternative components

a1	PTC starter (220V, 250hm, 6.3mm)	103N0011
b	plastic cover	103N2011
d	cord relief	103N1010
g	protection screen for PTC	103N0476

Model

Designation **NL8.4CLX** **220-240V/50Hz** Conf. 3 Sales code: **105F3800**

Optimization + standard conditions

R452A, 220V/50Hz, RSIR, fan 3m/s, VDE, EAC

		Evaporating pressure (saturation temperature)				Condensing pressure (saturation temperature)						Power consumption			
		Return gas temp.		Liquid temp.		Cooling capacity		COP	EER		P1	I	Ref. mass flow		
		pe	pc	RGT	Tliq	[W]	[Btu/h]	[kcal/h]	[W/W]	[Btu/Wh]	[kcal/Wh]	[W]	[A]	[kg/h]	
[°C]	[°F]	[°C]	[°F]	[°C]	[°F]										
-23	54	32	32	384,9	1315	331,3	1,25	4,27	1,08	307,6	1,86	9,25	ASHRAE LBP		
-10	130	90	90												
-25	55	32	55	263,0	898	226,3	0,90	3,06	0,77	293,5	1,81	8,37	cecomaf LBP		
-13	131	90	131												
-35	40	20	40	206,0	704	177,3	0,96	3,29	0,83	213,7	1,60	5,75	EN12900 LBP		
-31	104	68	104												
-23	49	4,4	49	295,0	1007	253,9	0,97	3,32	0,84	303,3	1,85	10,60	ARI540 LBP		
-10	120	40	120												
-23	41	32	32	440,6	1505	379,2	1,54	5,25	1,32	286,5	1,81	10,59	AHAM LBP		
-10	105	90	90												
-35	45	32	45	194,2	663	167,2	0,89	3,04	0,77	218,5	1,62	5,33	opt		
-31	113	90	113												

Performance tables

R452A, 220V/50Hz, RSIR, fan 3m/s, VDE, EAC

	pe		Cooling capacity			COP	EER	P1	I	m	
	[°C]	[°F]	[W]	[Btu/h]	[kcal/h]	[W/W]	[Btu/Wh]				[kcal/Wh]
[°C / °F]	-45	-49	94,3	322	81,2	0,61	2,08	0,52	154,7	1,50	2,58
cond. pressure	-35	-31	194,2	663	167,2	0,89	3,04	0,77	218,5	1,62	5,33
pc= 45/113	-30	-22	260,9	891	224,5	1,04	3,55	0,89	250,9	1,70	7,19
return gas temp.	-25	-13	340,6	1163	293,1	1,20	4,08	1,03	284,8	1,80	9,42
RGT= 32/90	-20	-4	434,9	1485	374,3	1,35	4,62	1,16	321,5	1,92	12,09
liquid temp	-15	5	545,3	1862	469,3	1,51	5,15	1,30	361,6	2,06	15,26
Tliq= 45/113	-5	23	820,6	2803	706,2	1,80	6,14	1,55	456,7	2,43	23,32
[°C / °F]	-45	-49	62,2	212	53,5	0,45	1,55	0,39	137,2	1,48	1,95
cond. pressure	-35	-31	143,1	489	123,2	0,67	2,29	0,58	213,8	1,60	4,51
pc= 55/131	-30	-22	197,4	674	169,9	0,78	2,67	0,67	252,8	1,69	6,25
return gas temp	-25	-13	263,0	898	226,3	0,90	3,06	0,77	293,5	1,81	8,37
RGT= 32/90	-20	-4	341,3	1165	293,7	1,01	3,46	0,87	337,0	1,96	10,92
liquid temp	-15	5	433,8	1482	373,3	1,13	3,86	0,97	384,3	2,14	13,98
Tliq= 55/131	-5	23	667,7	2280	574,6	1,35	4,62	1,16	493,8	2,62	21,91

Model

Designation	NL8.4CLX	220-240V/50Hz	Conf. 4	Sales code:	105F3800
-------------	-----------------	----------------------	----------------	-------------	-----------------

Configuration

Motorconfiguration	CSIR
Power supply (nominal)	220-240V/50Hz 1~
Refrigerant	R452A
Application	LBP
Voltage range	198-254V
Starting torque	HST
Approvals	VDE (2)
	(1): Made in China EAC (1),(2)
	(2): Made in Slovakia

Electrical accessories / wiring diagram

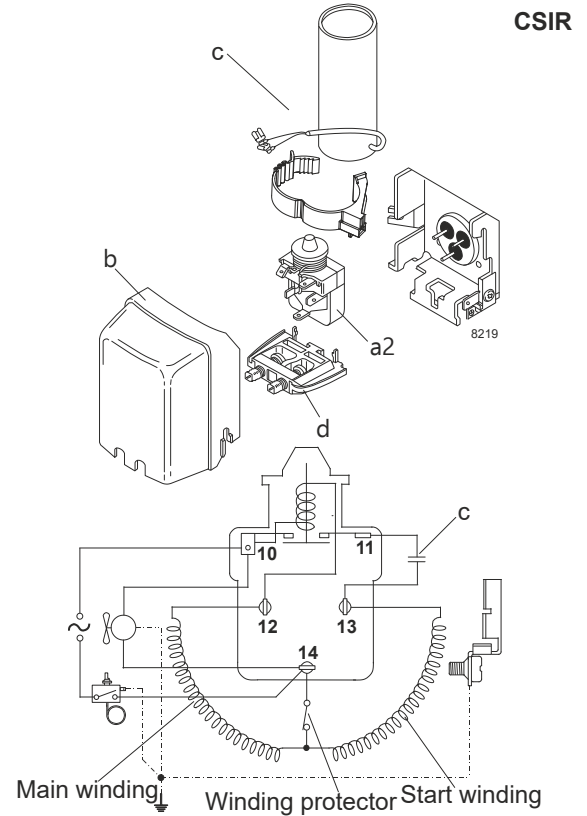

Ambient/ machine room temperatures minimum /maximum

Ambient temperature range:	10 - 38°C / 50 - 101°F
Machine room temperature range:	10 - 43°C / 50 - 110°F
Compressor cooling:	fan 3m/s

Operation Limits

Operation pressure range

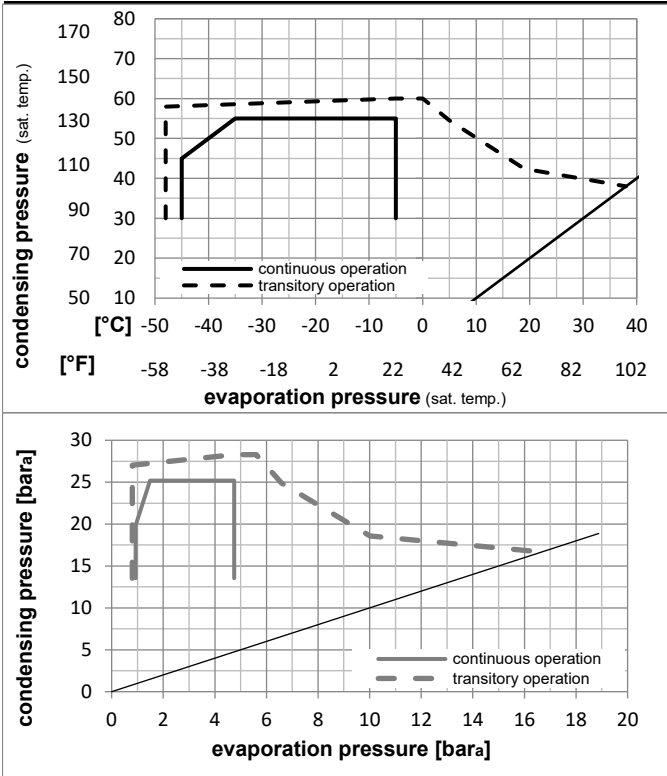

Components

a2	assy. relay	117U6003
c	start capacitor (80μF)	117U5015
b	plastic cover	103N2010
d	cord relief	103N1010

Alternative components

b	plastic cover	103N2011
---	---------------	----------

Model

Designation **NL8.4CLX** **220-240V/50Hz** Conf. 4 Sales code: **105F3800**

Optimization + standard conditions

R452A, 220V/50Hz, CSIR, fan 3m/s, VDE, EAC

		Evaporating pressure (saturation temperature)				Condensing pressure (saturation temperature)						Power consumption			
		Return gas temp.		Liquid temp.		Cooling capacity		COP	EER		P1	I	Ref. mass flow		
		pe	pc	RGT	Tliq	[W]	[Btu/h]	[kcal/h]	[W/W]	[Btu/Wh]	[kcal/Wh]	[W]	[A]	[kg/h]	
[°C]	[°F]	[°C]	[°F]	[°C]	[°F]										
-23	54	32	32	384,9	1315	331,3	1,25	4,27	1,08	307,6	1,86	9,25	ASHRAE LBP		
-10	130	90	90												
-25	55	32	55	263,0	898	226,3	0,90	3,06	0,77	293,5	1,81	8,37	cecomaf LBP		
-13	131	90	131												
-35	40	20	40	206,0	704	177,3	0,96	3,29	0,83	213,7	1,60	5,75	EN12900 LBP		
-31	104	68	104												
-23	49	4,4	49	295,0	1007	253,9	0,97	3,32	0,84	303,3	1,85	10,60	ARI540 LBP		
-10	120	40	120												
-23	41	32	32	440,6	1505	379,2	1,54	5,25	1,32	286,5	1,81	10,59	AHAM LBP		
-10	105	90	90												
-35	45	32	45	194,2	663	167,2	0,89	3,04	0,77	218,5	1,62	5,33	opt		
-31	113	90	113												

Performance tables

R452A, 220V/50Hz, CSIR, fan 3m/s, VDE, EAC

	pe		Cooling capacity			COP	EER	P1	I	m	
	[°C]	[°F]	[W]	[Btu/h]	[kcal/h]	[W/W]	[Btu/Wh]	[kcal/Wh]	[W]	[A]	[kg/h]
[°C / °F]	-45	-49	94,3	322	81,2	0,61	2,08	0,52	154,7	1,50	2,58
cond. pressure	-35	-31	194,2	663	167,2	0,89	3,04	0,77	218,5	1,62	5,33
pc= 45/113	-30	-22	260,9	891	224,5	1,04	3,55	0,89	250,9	1,70	7,19
return gas temp.	-25	-13	340,6	1163	293,1	1,20	4,08	1,03	284,8	1,80	9,42
RGT= 32/90	-20	-4	434,9	1485	374,3	1,35	4,62	1,16	321,5	1,92	12,09
liquid temp	-15	5	545,3	1862	469,3	1,51	5,15	1,30	361,6	2,06	15,26
Tliq= 45/113	-5	23	820,6	2803	706,2	1,80	6,14	1,55	456,7	2,43	23,32
[°C / °F]	-45	-49	62,2	212	53,5	0,45	1,55	0,39	137,2	1,48	1,95
cond. pressure	-35	-31	143,1	489	123,2	0,67	2,29	0,58	213,8	1,60	4,51
pc= 55/131	-30	-22	197,4	674	169,9	0,78	2,67	0,67	252,8	1,69	6,25
return gas temp	-25	-13	263,0	898	226,3	0,90	3,06	0,77	293,5	1,81	8,37
RGT= 32/90	-20	-4	341,3	1165	293,7	1,01	3,46	0,87	337,0	1,96	10,92
liquid temp	-15	5	433,8	1482	373,3	1,13	3,86	0,97	384,3	2,14	13,98
Tliq= 55/131	-5	23	667,7	2280	574,6	1,35	4,62	1,16	493,8	2,62	21,91



8238-20

NL Compressors

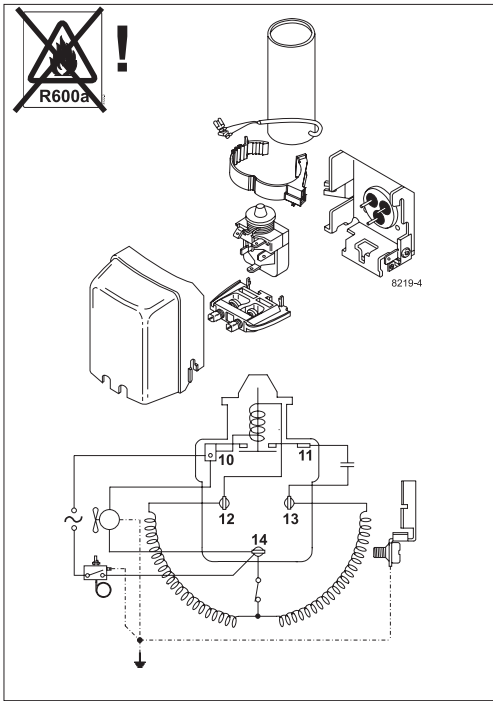



Service/Repair – R600a, R290



8545

Brazing on Suction Connectors (Direct Intake)

representative image



**! max. 150°C/302°F !
at socket**
brazing solder: phosphor (LP7) or silver

Refer to Product Bulletin:
**Brazing on Suction Connectors
(Compressors with Direct Suction Intake)**

Secop accepts no responsibility for possible errors in catalogs, brochures, and other printed material. Secop reserves the right to alter its products without notice. This also applies to products already on order provided that such alterations can be made without subsequential changes being necessary to specifications already agreed. All trademarks in this material are the property of the respective companies. Secop and the Secop logotype are trademarks of Secop GmbH. All rights reserved. www.secop.com