

Single Pack FF7.5GK 115V 60Hz RSIR

Single pack code number: **195B4108**

Position	Title	Code	Amount
1	Compressor FF7.5GK	103G5780	1
2	Starting relay (overload protector MRP38JL-6)	117U4085	1
3	Cord relief	117U0349	1
4	Cover	117U1021	1
5	Bolt joint for one compressor M6 ø16mm	118-1917	1

Secop GmbH • Lise-Meitner-Straße 29 • 24941 Flensburg, Germany • Tel: +49 461 4941 0 • www.secop.com

Secop accepts no responsibility for possible errors in catalogs, brochures, and other printed material. Secop reserves the right to alter its products without notice. This also applies to products already on order provided that such alterations can be made without subsequent changes being necessary to specifications already agreed. All trademarks in this material are the property of the respective companies. Secop and the Secop logotype are trademarks of Secop GmbH. All rights reserved.

FF7.5GK Universal Compressor R134a 115V 60Hz

General

Code number	103G5780
Approvals	UL984
Compressors on pallet	80

Application

Application	LBP/HBP			
Frequency	Hz	50	60	
Evaporating temperature	°F	-	-22 to 50	
Voltage range	V	-	103 - 127	
Max. condensing temperature continuous (short)	°F	-	140 (158)	
Max. winding temperature continuous (short)	°F	-	257 (275)	

Cooling requirements

Frequency	Hz	50			60		
Application		LBP	MBP	HBP	LBP	MBP	HBP
90°F		-	-	-	F ₁	F ₁	F ₁
100°F		-	-	-	F ₁	F ₁	F ₁
110°F		-	-	-	F ₁	F ₁	F ₁
Remarks on application:							

Motor

Motor type	RSIR		
LRA (rated after 4 sec. UL984), HST LST	A	-	25.0
Cut in Current, HST LST	A	-	25.0
Resistance, main start winding (77°F)	Ω	2.2	8.3

Design

Displacement	cu.in	0.42
Oil quantity (type)	fl.oz.	13.5 (polyolester)
Maximum refrigerant charge	oz.	32.0
Free gas volume in compressor	fl.oz.	47.3
Weight without electrical equipment	lbs.	23.3

Dimensions

Height	inch	A	7.72
		B	7.52
		B1	-
		B2	-
Suction connector	location, I.D. in. angle	C	0.320-0.327 30°
	material comment		Cu-plated steel Al cap
Process connector	location, I.D. in. angle	D	0.252-0.259 30°
	material comment		Cu-plated steel Al cap
Discharge connector	location, I.D. in. angle	E	0.252-0.259 25°
	material comment		Cu-plated steel Al cap
Oil cooler connector	location, I.D. in. angle	F	-
	material comment		-
Remarks:			

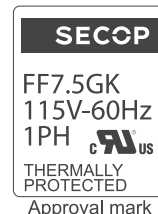
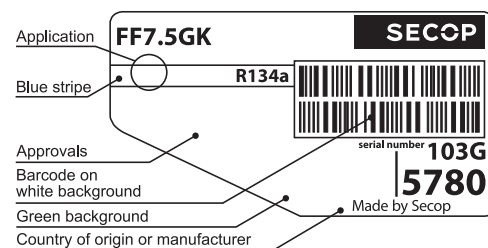

- S = Static cooling normally sufficient
- O = Oil cooling
- F₁ = Fan cooling 1.5 m/s
(compressor compartment temperature equal to ambient temperature)
- F₂ = Fan cooling 3.0 m/s necessary
- SG = Suction gas cooling normally sufficient
- = not applicable in this area

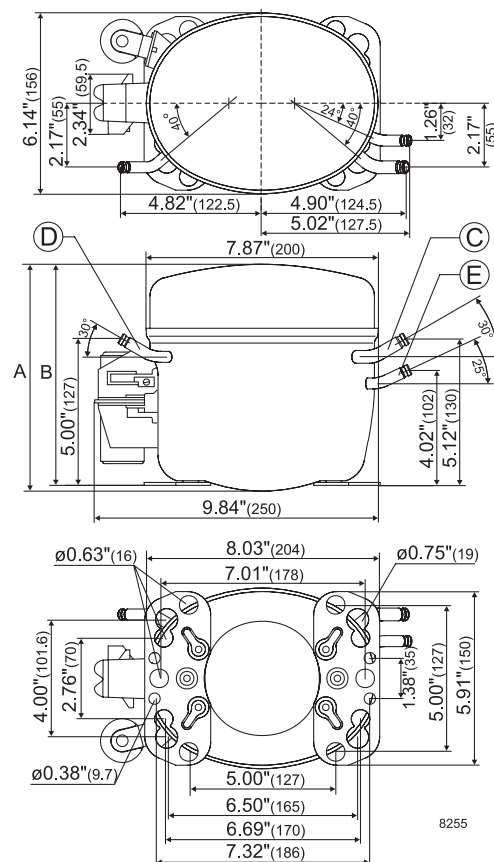

ASHRAE LBP

115V, 60Hz, fan cooling F₁

Evap. temp. in °F	-49	-40	-30	-20	-13	-10	0	10	14	20	30	32	40	45	50	59	68
Capacity in BTU/h				328	452	516	777	1111	1258	1518	2000	2100	2556	2863	3189		
Power cons. in W				115	138	148	182	216	230	250	286	294	322	340	359		
Current cons. in A				1.90	2.02	2.07	2.28	2.51	2.61	2.76	3.03	3.10	3.32	3.47	3.62		
EER in BTU/Wh				2.86	3.28	3.49	4.27	5.15	5.46	6.06	7.00	7.16	7.94	8.41	8.88		

ASHRAE HBP

115V, 60Hz, fan cooling F₁

Evap. temp. in °F	-49	-40	-30	-20	-13	-10	0	10	14	20	30	32	40	45	50	59	68
Capacity in BTU/h				291	401	458	689	984	1128	1344	1769	1872	2259	2529	2816		
Power cons. in W				115	138	148	182	216	229	250	286	292	322	340	359		
Current cons. in A				1.90	2.02	2.07	2.28	2.51	2.61	2.76	3.03	3.09	3.32	3.47	3.62		
EER in BTU/Wh				2.54	2.91	3.09	3.79	4.56	4.91	5.37	6.19	6.41	7.02	7.43	7.84		

EN 12900 Household (CECOMAF)

115V, 60Hz, fan cooling F₁

Evap. temp. in °F	-49	-40	-30	-20	-13	-10	0	10	14	20	30	32	40	45	50	59	68
Capacity in W				79	108	123	186	265	299	362	477	498	608	681	757		
Power cons. in W				115	138	148	182	216	230	250	286	294	322	340	359		
Current cons. in A				1.90	2.02	2.07	2.28	2.51	2.61	2.76	3.03	3.10	3.32	3.47	3.62		
COP in W/W				0.69	0.78	0.83	1.02	1.23	1.30	1.45	1.67	1.69	1.89	2.00	2.11		

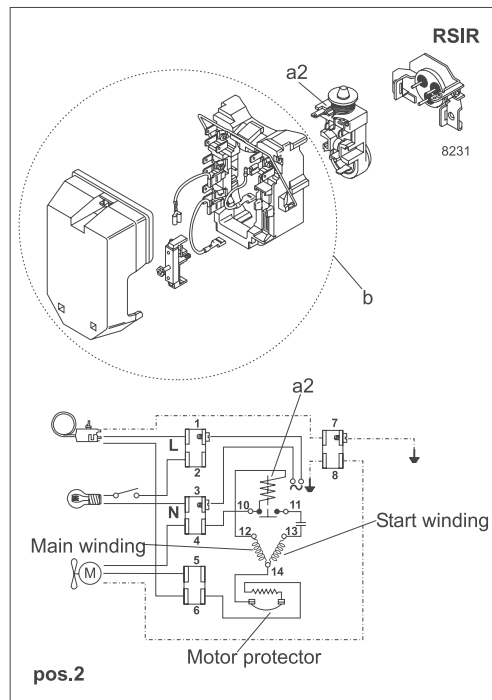

Accessories for	FF7.5GK	Figure	Code number
Starting relay	1/4 in. spade connect.	a2	117U4085
Protector 3/4 in.	Texas Instruments		MRP38JL-6
Cover (standard)		b	117U1021
Cord relief		d	117U0349
		(pos.1)	
Cover (alternative) with terminal board		b	117U1024
		(pos.2)	

Test conditions	ASHRAE LBP	ASHRAE HBP	EN 12900/CECOMAF
Condensing temp.	130°F	130°F	131°F
Ambient temp.	90°F	95°F	90°F
Suction gas temp.	90°F	95°F	90°F
Liquid temperature	90°F	115°F	131°F

Mounting accessories	Code number	
Bolt joint for one comp.	Ø: 5/8 in.	118-1917
Bolt joint in quantities	Ø: 5/8 in.	118-1918
Snap-on in quantities	Ø: 5/8 in.	118-1919

Secop accepts no responsibility for possible errors in catalogs, brochures, and other printed material. Secop reserves the right to alter its products without notice. This also applies to products already on order provided that such alterations can be made without substantial changes being necessary to specifications already agreed. All trademarks in this material are the property of the respective companies. Secop and the Secop logotype are trademarks of Secop GmbH. All rights reserved. www.secop.com

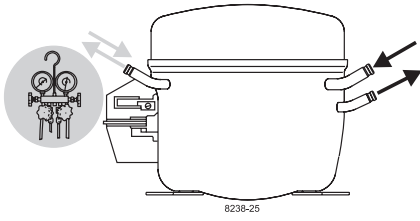

FF Compressors

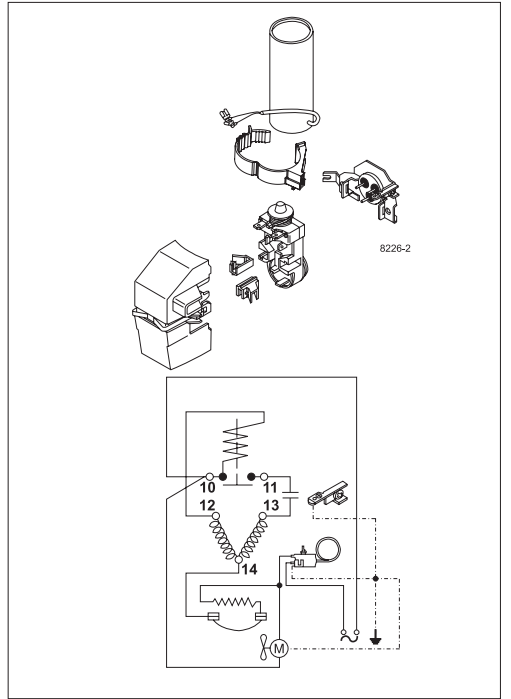
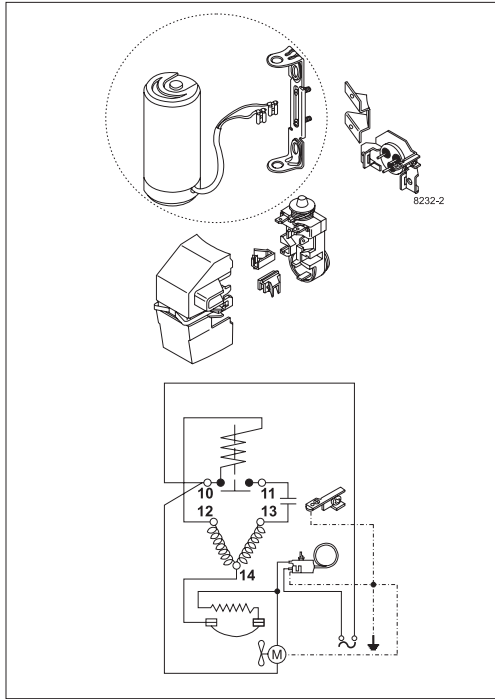
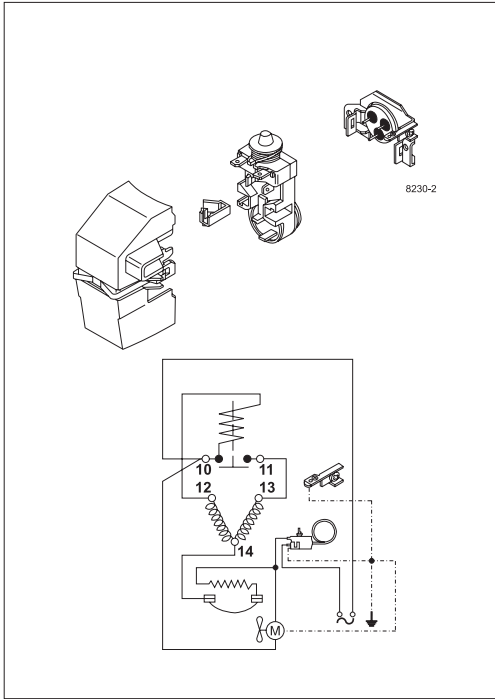



FF Compressors



8238-25



Secop accepts no responsibility for possible errors in catalogs, brochures, and other printed material. Secop reserves the right to alter its products without notice. This also applies to products already on order provided that such alterations can be made without subsequential changes being necessary to specifications already agreed. All trademarks in this material are the property of the respective companies. Secop and the Secop logotype are trademarks of Secop GmbH. All rights reserved. www.secop.com